



Resistance Spot Welder

Instruction Manual

MNL-i5s-v1.0



About Pro Spot

Pro Spot International specializes in quality welding and repair products for the collision repair industry. Pro Spot owns numerous patents for special welding equipment and applications, and works with the largest auto manufacturers in the world. Pro Spot is a proud 'MADE IN THE USA' manufacturer in Carlsbad, CA. The turnkey facility includes Design, Engineering, Machine and Sheet Metal Shops, Powder Coating, Assembly, Training and Customer Support. The Pro Spot equipment line includes resistance spot welders, aluminum & steel dent repair systems, pulse MIG welders, rivet guns and tools, dust-free sanding systems, fume extraction and more.

Pro Spot Training and Services

Pro Spot provides on-going training to all of our distributors and their technicians, therefore, all owners of Pro Spot products receive complete training first hand. Pro Spot has two ASE certified training programs that are I-CAR Alliance approved. Pro Spot has a fully equipped training facility at their Headquarters in Carlsbad, CA, as well as in Nashville, TN, and Denver, CO, for groups to come in and train on all products. To stay up-to-date, Pro Spot offers their unique my.prospot.com which includes interactive training courses for shops and technicians to access online.

Pro Spot is constantly striving to improve. Whether that means designing innovative equipment, implementing cutting edge technical support or further improving their already extensive training programs, Pro Spot is always looking for ways to better our customer's experiences.



PRO SPOT

QUALITY WELDING SYSTEMS

Pro Spot International, Inc.
5932 Sea Otter Place
Carlsbad, CA 92010

Toll Free: (877) PRO SPOT
Phone: (760) 407-1414
Fax: (760) 407-1421

E-mail: info@prospot.com
Web: www.prospot.com



[Spot Welding](#)

[MIG Welding](#)

[Plastic Welding](#)

[Riveting](#)

[Dustless Sanding](#)

[Dent Pulling](#)

[Plasma Cutting Solutions](#)

[Other Products](#)

[Tech Tips](#)

[OEM Info](#)

Visit support.prospot.com

Support.prospot.com is an invaluable resource for owners of Pro Spot equipment. With a comprehensive library of manuals, videos, brochures, and component lists, this website offers a wealth of information to help users make the most of their Pro Spot products. Whether you're looking for detailed instructions on how to use a particular tool or need help troubleshooting an issue, support.prospot.com has you covered. The site's user-friendly design and intuitive navigation make it easy to find the information you need quickly and efficiently. Whether you're a seasoned professional or a novice user, support.prospot.com is an essential tool for anyone who wants to get the most out of their Pro Spot equipment.

Table Of Contents

i5s Quick Start Instructions	1
1.0 Introduction	2
2.0 Safety	3
2.1 Important Warnings	4
2.2 Cooling System	5
3.0 Installation	6
3.1 Packaging & Delivery Inspection.....	6
3.2 Welder Assembly	6
3.3 Connecting The Electrical Supply.....	7
3.4 Connecting the Pneumatic Air Supply	7
4.0 Operation	8
4.1 Before You Begin Welding	8
4.2 About Your Welder	9
5.0 Getting Started	10
5.1 Turning On The i5s	10
5.2 How To Login	11
5.3 i5s Home Screen	12
5.4 Double-Acting Spot Gun.....	13
5.5 i5s On-Gun Screen & Gun Controls.....	14
5.6 Extension Arms.....	16
6.0 i5s General Settings	17
6.1 WIFI Menu	17
6.2 Cooling Menu	18
6.3 Data and Time Menu	19
6.4 Brightness Menu.....	19
6.5 My Account Menu	20
6.6 System Info Menu.....	21
6.7 i5s Admin Settings Menu	22
6.8 Admin: Work Orders	23
6.9 Admin: User Menu	27
7.0 Auto Mode	30
7.1 Auto Mode Menu Guide	30
7.2 Auto Mode Measurement Only Mode	31
7.3 Auto Mode Calibration	32
8.0 Manual Mode Welding Menu Guide	33
8.1 Double Sided Welding Manual Mode	35
8.2 Manual Mode Welding: Dual Weld Settings	36
8.3 Manual Mode Welding: Pulse Weld Settings.....	37
8.4 Creating A Custom Weld.....	38
9.0 Two-Sided Welding (Semi-Auto Mode)	40
10.0 Welding Electrode Maintenance	43
10.1 Electrode Components	43
10.2 Welding Electrode Maintenance.....	44
10.3 Weld Cap and Tip Dresser Identification Tables.....	45
10.4 i5s Cap and Shank Removal.....	46

i5s Quick Start Instructions



WARNING! Read this manual in its entirety before attempting to weld with the i5s. Before turning on the machine, make sure it is connected to the proper electricity by certified professionals. The water tank should be filled with a 50/50 water and antifreeze solution. Before filling, make sure to secure all water hoses.

1 Weld Gun Check

- (A) Verify that the hoses are secure in place.
- (B) Verify that the arm handle is tightened.
- (C) Verify that weld caps are installed

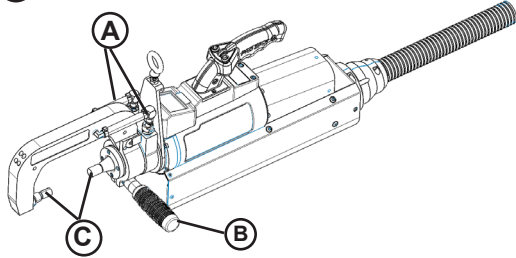

2 System Checks and Power On

- (A) Verify the presence of air pressure. Recommended minimum input pressure is at least 100 PSI. See Section 4.2.1 for more information.



(C) Turn power on.

- (B) Verify all 3-phase lights are illuminated.

3 Login

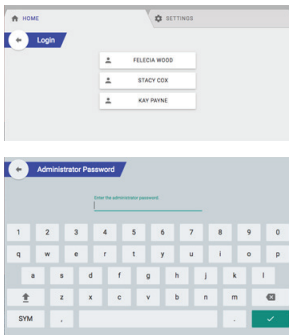

(A) Select User Login.

(B) Enter the password and select the green check button.

Note: The default user password is 1234

4 Navigation

(A) The i5s touch screen is used to navigate through menus and select options.

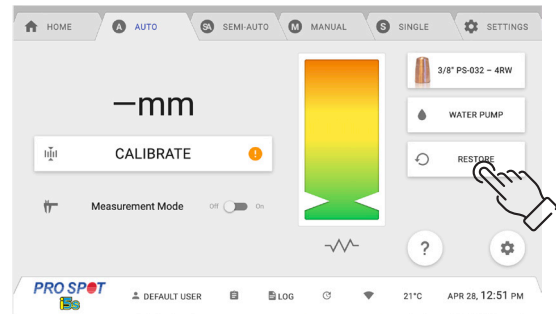

5 How To Calibrate The i5s Spot Welding Gun for Auto Welding

CAUTION DO NOT PUT MATERIAL BETWEEN ELECTRODES DURING CALIBRATION

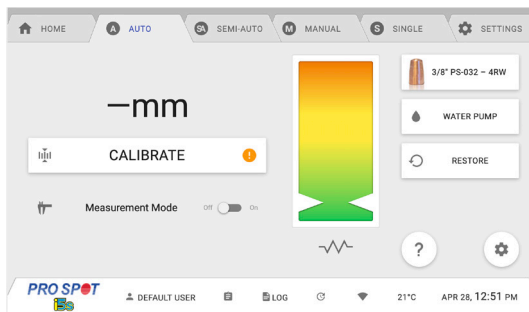

1. Press the calibrate button to enter calibration mode.
2. Press and hold the reverse button (top-left) on the gun.
3. Press and hold the weld trigger and the top right button on the gun to calibrate.

Note: • Recalibrate every 100 welds
• Every arm change
• Every time Auto Mode is entered.

6 Start Welding

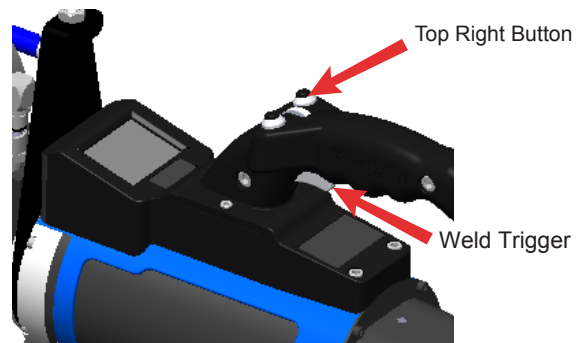

1. Place the stackup between the weld caps and be sure to use shunt clamps if this is the first weld.
2. Press and hold the weld trigger and top right button on the gun to close the gun and produce a weld.

1.0 Introduction

Congratulations on your new Pro Spot i5s Spot Welder!

With the i5s and its connected support system, you will experience a rapid increase in productivity. The integrated and user friendly features, paired with superior speed and overall weld quality will quickly make the i5s a vital element of your business.

Team Pro Spot looks forward to supporting you.

For videos on products, training and tips, visit our YouTube Channel: www.youtube.com/prospotinternational

To speak to a customer service representative visit www.prospot.com or e-mail us at support@prospot.com.

For parts or service contact your local distributor, or call Toll free: 1-877 PRO-SPOT (US only) or 1-760-407-1414

The following information will be needed when you call Pro Spot:

*MODEL TYPE: i5s

*SERIAL NO: _____ (The serial number is located on the left side of the unit)

The i5s Spot Welder is used by body shops for the purpose of duplicating weld procedures implemented by vehicle manufacturers.

Pro Spot International, Inc. will not be held responsible in any way for intentional or unintentional damage caused by incorrect use of this equipment or using the equipment for an unintended application.

Warranty

Pro Spot International, Inc. offers a limited two-year guarantee initiated on the date of delivery of the new welder. This guarantee covers material defects and assumes normal care and maintenance.

This guarantee assumes that:

- The equipment is correctly installed and inspected by a certified Pro Spot representative.
- The equipment has not been altered or rebuilt without approval from Pro Spot International, Inc.
- Genuine Pro Spot International, Inc. parts and consumables are used to make repairs.
- Preparation and maintenance has been carried out according to the instructions in this manual.

All claims on warranty must verify that the fault has occurred within the guarantee period, and that the unit has been used within its operating range as stated in the specifications. All claims must include the product type and serial number. This data is stamped on the name plate.

Note: This instruction manual provides advice as well as instructions for installation, operation, maintenance and troubleshooting.



IMPORTANT! Read this manual carefully to become familiar with the proper operation of the welder. Do not neglect to do this as improper handling may result in personal injury and damage to the equipment.



IMPORTANT! Lisez ce Mode d'Emploi attentivement afin de vous familiariser avec le bon fonctionnement du soudeur. Ne négligez pas de le faire puisque une mau-vaie manipulation peut conduire aux blessures et dommages à l'équipement.

This manual is to be used for illustrative purposes only. It does not necessarily include the design of the equipment available on the market at any given time. The equipment is intended for use in accordance with current trade practice and appropriate safety regulations. The equipment illustrated in the manual may be changed without prior notice.

The contents in this publication can be changed without-prior notice.

The information featured in this publication is protected by copyright laws. No part of this publication may be reproduced, stored in a system for information retrieval or be transmitted in any way without Pro Spot International, Inc.'s written consent.

Conformity with directives and standards: i5s complies with CE standards.

2.0 Safety

Safety & Environmental Specifications

The i5s Spot Welder is designed for indoor use - Protection Degree IP21S. The i5s Spot Welder is designed to operate from -10° C to 40° C. The unit may be stored and transported in an ambient temperature from -20° C to +55° C. The unit can be operated at 95% Relative Humidity (RH). Do not operate the unit on a slope of more than 10°.

General

The i5s Spot Welder has been designed and is tested to meet strict safety requirements. Please read the following instructions carefully before operating the i5s and refer to them as needed to ensure the continued safe operation of the welder.

Information provided in this manual describes the suggested best working practices and should in no way take precedence over individual responsibilities or local regulations.

The i5s Spot Welder is designed to comply with all applicable safety regulations for this type of equipment. During operation, it is the responsibility of each individual user to consider:

- The personal safety of themselves and others.
- The safety of the welder through the proper use of the equipment and in accordance with the descriptions and instructions provided in this manual.

By observing and following the safety precautions, users of the i5s Spot welder warrant safer working conditions for themselves and others.

2.1 Warnings & Important Notices

The following types of safety signs are used on the equipment and in Pro Spot's instruction manuals:



Caution.
Read instruction manual.



Attention!
Lire Mode d'Emploi.



Prohibited.
Prohibits behavior that can cause injury.



Interdit.
Interdit aux comportements qui peuvent provoquer des blessures.



Command.
Calls for a specific action.



Commande.
Appelle à une action spécifique.



Warning.
Notice of personal injury risk and or damage to equipment.



Avertissement.
Avis de risque de blessure personnelle et / ou d'endommager l'équipement.



Warning.
Some parts of the welder may become hot after prolonged use.



Avertissement.
Certaines parties du soudeur peuvent devenir chaudes après une utilisation prolongée.



WARNING! Do not operate or place the welder near water, in wet locations or outdoors. Risk for injuries or damage to the welder.



WARNING! Do not place the welder on unstable or uneven ground. The welder might tip causing personal injuries or serious damage to the welder.



WARNING! Risk of electrical shock. All electrical connections must be made by a qualified electrician.



WARNING! Loose cables and hoses present tripping risks and possible injuries.



WARNING! Always use welding goggles when spot welding. Sparks are capable of causing injury to the eyes.



WARNING! Sparks from welding could start a fire, causing injury and property damage.



WARNING! Risk of damage to materials close to the welder, e.g to glass or textiles.



WARNING! For proper cooling efficiency, never operate the welder without connecting it to the compressed air source.



WARNING! All service and maintenance must be carried out by Pro Spot service personnel and service support.



WARNING! Risk for electrical shock. Unplug the welder from its electrical outlet before servicing, cleaning or maintenance of any kind.



IMPORTANT! The i5s welder may only be used by qualified personnel. Individuals using the welder must be educated in spot welding, collision repair and proper usage of the unit.



IMPORTANT! Do not turn off the welder while cooling is activated!



IMPORTANT! The air must be clean and free from oil and moisture. Use filter.



WARNING! Do not place any body parts between the electrode tips. Doing so will cause serious injury.



WARNING! When holding the gun, only hold it by the plastic handle on top and the rubber handle on the arm.



ATTENTION! Ne pas faire fonctionner le soudeur près de l'eau, en voie humide, ou à l'extérieur. Risque de blessures ou de dommages au soudeur.



ATTENTION! Ne placez pas le soudeur sur un sol instable ou irrégulière. Le soudeur peut basculer causant des lésions corporelles ou des dommages graves au soudeur.



ATTENTION! Toutes les connexions électriques doivent être faites par un électricien qualifié. Risque de choc électrique.



ATTENTION! Câbles et tuyaux lâches présentent des risques de déclenchement. Risque de blessures



ATTENTION! sur place. Les étincelles pourraient autrement blesser les yeux.



ATTENTION! Étincelles de soudure pourrait provoquer une incendie. Risque de blessures.



ATTENTION! Risque de dommages aux matériaux à proximité de la soudure, par exemple verre ou textiles.



ATTENTION! Pour refroidissement efficace, ne jamais soudeur sans attacher à la source d'air comprimé.



ATTENTION! Tout le service et l'entretien doivent être effectués par personnel et soutien de service Pro Spot. Risque de choc électrique.



ATTENTION! Débranchez le soudeur de la prise murale avant l'entretien, ou nettoyage. Risque de choc électrique.



IMPORTANT! Le soudeur i5s peut seulement être utilisé par personnel qualifié. L'utilisateur du soudeur doit avoir une connaissance de soudage par points et l'alignement des véhicules endommagés par collisions.



IMPORTANT! N'éteignez pas le soudeur pendant que le refroidissement est activé!



IMPORTANT! L'air doit être propre et sans huile et humidité. Utilisez un filtre



IMPORTANT! Ne placez aucune partie du corps entre les pointes d'électrode. Cela le fera causer des blessures graves.



IMPORTANT! Lorsque vous tenez le pistolet, tenez seulement par la poignée en plastique sur le dessus et le caoutchouc gérer sur le bras.

2.2 Cooling System

IMPORTANT! To ease transportation, the i5s welder is DELIVERED WITHOUT COOLANT. Be sure to fill coolant tank before turning on the welder. The cooling system turns on and off automatically. It starts at the first weld and shuts off 25 minutes after the last weld is completed. Make sure the water lines are connected properly.

The coolant tank is located under the main upper part of the unit, inside the center column. It should be filled with a 50/50 water & antifreeze solution. Maintain a level of at least 10L of 50/50 solution at all times and do not overfill. When filling coolant it is recommended that a funnel be used to prevent unnecessary spills. When handling antifreeze or 50/50 solution, avoid contact with skin, eyes, or mouth. See antifreeze directions for proper handling instructions.



The i5s is equipped with a closed loop cooling system, 5-gallon (20L) tank, radiator with high powered fan cooling all the way to the tip of the electrodes.

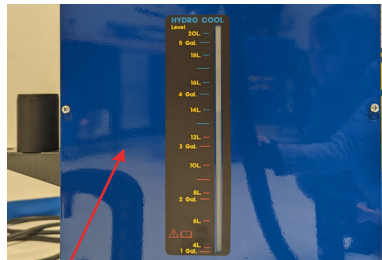

The Coolant Level Indicator (located under the upper part of the cabinet), should be checked regularly to maintain 10L minimum in the tank.

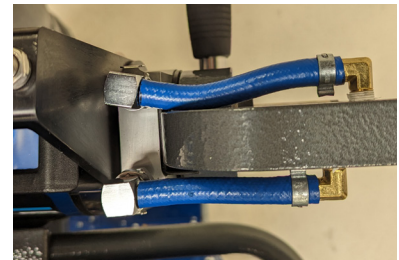

Make sure the water cooling hoses are securely clipped into place before welding. Water will leak if the water feed and return hoses are not properly connected (see cooling hose connections).

Always make sure the welding arm is installed correctly, and the arm handle is firmly secured.



IMPORTANT! Make sure the water cooling hoses are securely clipped into place before welding.

IMPORTANT! Turn off the power to the water pump before disconnecting water hoses from the weld gun.

IMPORTANT! The i5s welder comes without coolant to ease transportation, be sure to fill coolant tank before turning on the welder.

IMPORTANT! If the thermal breaker has tripped and shut off the welder, please contact Pro Spot's authorized service personnel.

IMPORTANT! N'éteignez pas le soudeur pendant que le système de refroidissement est activé!

IMPORTANT! Si le disjoncteur thermique a éteint le soudeur, s'il vous plaît contactez personnel de service autorisé Pro Spot.

3.0 Installation

General

The i5s Spot Welder is inspected and tested prior to leaving the factory to guarantee consistent quality and the highest possible reliability. Follow the installation tips and operating instructions below to ensure user safety and proper welder performance.

WARNING! Do not operate or place the welder near water, in wet locations or outdoors. Risk for injuries or damage to the welder.



WARNING! Do not place the welder on unstable or uneven ground. The welder might fall causing personal injuries and damage to the welder. Do not operate on a slope of more than 10 degrees.

WARNING! When moving the welder, always check to make sure the wheel-locks are disengaged. Move the welder by grabbing the wraparound handle. Lock wheels in place prior to welding.

IMPORTANT! It is the responsibility of the owner to ensure that the equipment has been installed and inspected in accordance with applicable regulations, and all users are trained on safety and usage before it is put into service.

ATTENTION! Ne pas faire fonctionner le soudeur près de l'eau, en voie humide ou à l'extérieur. Risque de



ATTENTION! Ne placez pas le soudeur sur un sol instable ou irrégulière. Le soudeur peut tomber causant

ATTENTION! Lorsque vous déplacez la soudeuse, vérifiez toujours que les verrous de roue sont désengagés des dommages graves au soudeur. Ne pas utiliser sur une pente de plus de 10°

IMPORTANT! C'est la responsabilité du propriétaire de s'assurer que l'équipement a été installé commespécifié dans les instructions fournies. C'est aussi la responsabilité du propriétaire de s'assurer que lesoudeur est inspecté conformément à la réglementation applicable avant qu'il ne soit mise en service.en service. Ne pas utiliser pour dégelé les conduites d'eau congelées (17.1) blessures ou de dommages au soudeur. et que vous les déplacez en saisissant la poignée enveloppante.

3.1 Packaging & Delivery Inspection

Check the contents of the shipping container against the packing list, consignment note, or other delivery documentation to verify that everything is included and in the correct quantity. Check the i5s Spot Welder carefully to make sure that no damage has occurred during transport. If anything is damaged or missing, the welder may be unsafe to use until the part is repaired or replaced. If anything is missing, please contact your supplier. Remove all packaging material from the welder as items may be wrapped in packing materials. .

3.2 Welder Assembly

For your convenience, the i5s welder ships fully assembled, with the exception of the support arm (boom).

Due to differences in wiring codes and connection methods, no electrical plug comes with the welder. Consult a certified electrician for proper installation of the electrical plug.

Insert the support arm (boom) as shown in Figure 3.1

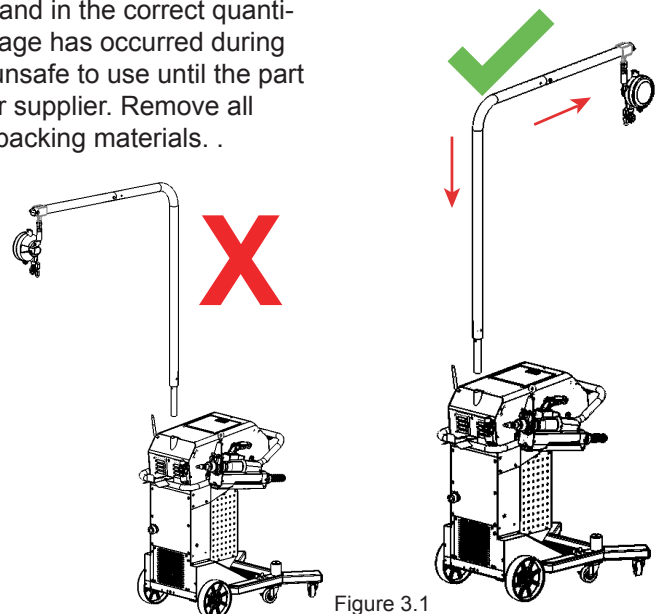

Figure 3.1

3.3 Connecting The Electrical Supply

The i5s Spot Welder is purchased based on voltage supply available at the shop. The i5s can be purchased in the following voltage / frequency combinations:

208-240V 50/60 Hz	U.S.A., Canada, Japan
400-480V 50/60 Hz	Europe, Australia U.S.A., Canada, Asia

WARNING: Plugging a machine into the wrong voltage can damage the machine.

Note: Make sure that the facility supply voltage and frequency are the same as shown on the welder name plate.

The power supply must have a ground connection. The supply must also be protected as follows:

The 208-240V 3-Phase requires a 60A breaker.

The 400-480V 3-Phase supply requires a 32A slow blow fuse (circuit breaker 32D).



WARNING! All electrical connections must be made by a qualified electrician. Risk for electrical shock.

ATTENTION! Toutes les connexions électriques doivent être faites par un électricien qualifié. Risque de choc électrique.

1. Connect the green wire to ground.

Note: Make sure that the supply cable is at least 6 AWG at 208V and 400V. The i5s is rated for over voltage category III and pollution degree 3.

2. If an extension cord is used with the welder, ensure that the length of the extension cord does not exceed 10m (30ft) and it meets the specifications of item 1 above. The cord must also be grounded. Consult an electrician for safe and proper installation of the electrical plug.

3.4 Connecting the Pneumatic Air Supply

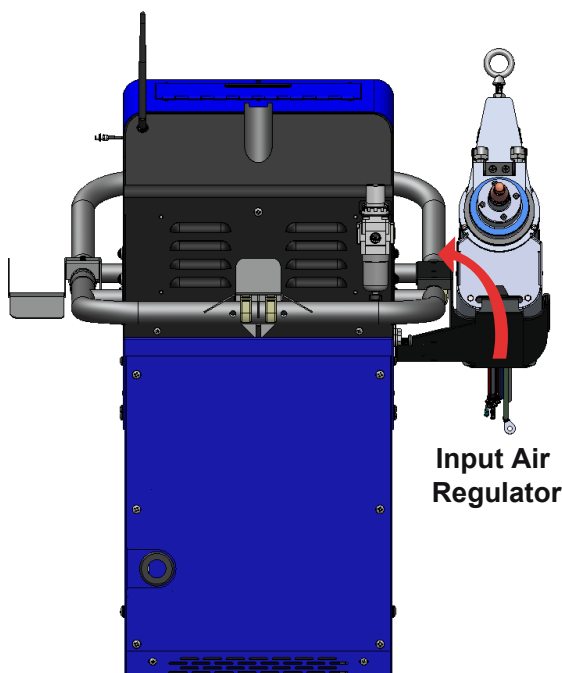

The i5s Spot Welder must be connected to a pneumatic air system (100 PSI to 130 PSI).

Connect the air supply via the 1/4 NPT input port on the input regulator at the rear of the welder using a standard connector.



IMPORTANT! The air must be clean and free from oil and moisture. Use a filter.

IMPORTANT! L'air doit être propre sans huile et humidité. Utilisez un filtre.

Figure 3.2

4.0 Operation

4.1 Before You Begin Welding

Before you begin welding, be sure to read and understand the following instructions.

The Pro Spot i5s is a state-of-the-art Resistance Spot Welder that was designed for the collision repair industry. It is important to understand the design and function of this welder before operating it.

Before you begin welding with the i5s:

Squeeze Force: The i5s double-sided gun contains an air cylinder that is capable of compressing the weld caps against the weld stack up to 1,240 lbs. In Auto Mode, the i5s automatically adjusts the squeeze force to maximize fusion of materials and minimize expulsion during the welding.

Energy: In Auto Mode, the i5s controls and monitors the amount of energy delivered to each weld which ultimately determines the overall quality of the weld. Perform regular destructive tests on the metal you are welding to validate the weld no matter which mode you are in.

Current: Another important aspect of a weld is the current applied through the work piece. A weld is created when the current is transferred through the layers of sheet metal. The resistance in the metal causes the area to heat up and fuse the sheets together in a nugget.

Weld Program: Maintaining the air pressure after the current shuts off makes the weld cool down under pressure resulting in a harder, stronger weld. This feature is built in to the i5s weld control program and is engaged automatically during a weld cycle.

Time: The Time controls the duration of the current applied during the weld cycle.

4.2 About Your Welder

The welder is supplied with one of the following voltage and frequency combinations:

Input Voltage: 3 phase
208-240V 50/60 Hz.
400-480V 50/60 Hz.

The actual voltage and frequency is stated on the rear panel name plate. Open circuit output voltage 20v max. E.M.C. classification is CISPR 11.

Welding Amperage: 14,500Amp max (3-phase)
Cable Length: Weld cable 16' (5m)
Electrode Force: 1,240 lbs. max (565 daN)

Cooling System: Radiator / pump active loop cooled to the weld caps.

Micro Processor: i5s Wirelessly Upgradeable Software Platform

Shipping Weight (standard): 440 lb (200 kg)

Weld Head Weight: 26 lb (12 kg)



Figure 4.1 i5s-Overview



The name plate is at the side of the welder unit. The required voltage is indicated on the label. Welding output is rated at 15V.

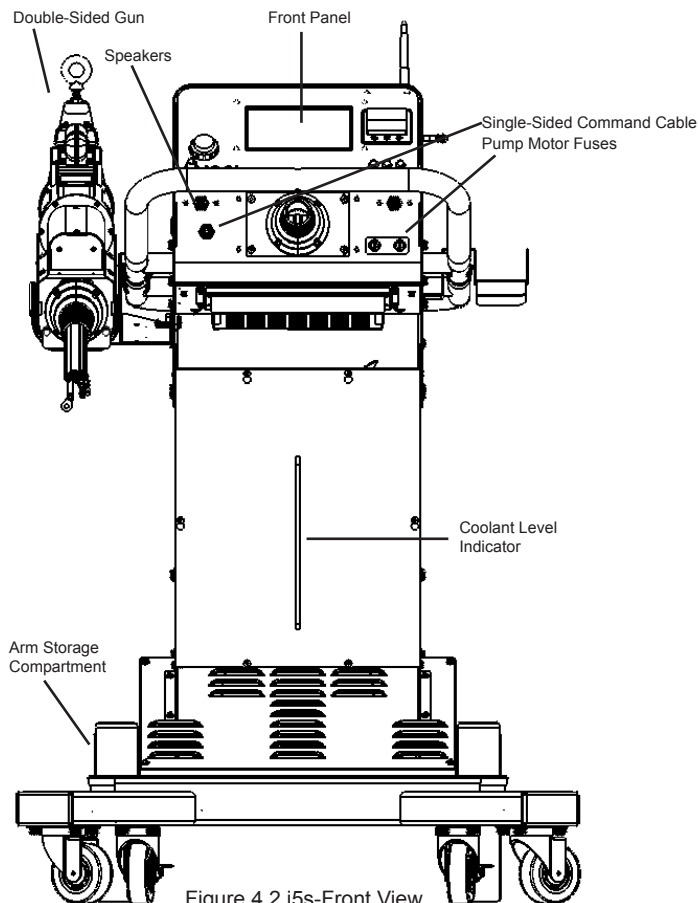

Figure 4.2 i5s-Front View

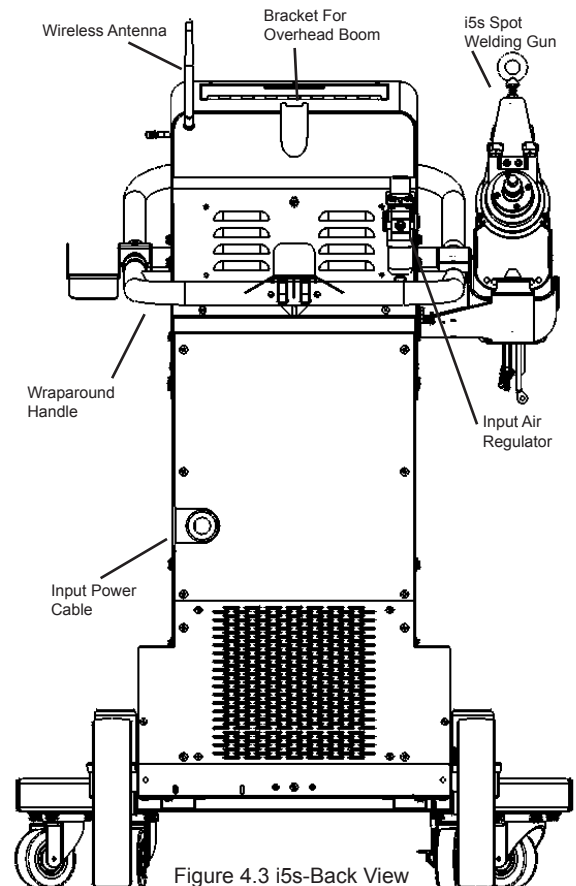

Figure 4.3 i5s-Back View

5.0 Getting Started

5.1 Turning On The i5s



Figure 4.4

1. The 3-phase indicator (3 LEDs on the front panel) should always be illuminated while the welder is plugged in (verify this before turning on the power). Switch the circuit breaker on the front panel to “ON”.
2. The display will go through the start-up procedure.
3. The i5s is now ready to use.



IMPORTANT! Make sure to read the instruction manual before operating the welder. Only trained personnel should use this welder.

IMPORTANT! Assurez-vous de lire le Mode d'Emploi avant d'opérer le soudeur. Seul le personnel qualifié devrait utiliser ce soudeur.

WARNING! READ THE FOLLOWING BEFORE WELDING

	When in use - the i5s discharges a large magnetic field which can negatively effect medical implant devices such as pacemakers.		Some parts of the welder may become hot after prolonged use.
	When in use - The i5s discharges a large magnetic field which can negatively effect electronics and attract metal to the gun.		Always wear eye protection when welding. Showers of sparks will periodically fly up from the material being welded.
	Unplug the welder from the wall outlet before servicing, cleaning, or maintenance. Risk of electrical shock.		Be wary of pinch points on the i5s such as the electrodes / weld caps on the double-sided gun.

5.2 How To Login

How To Login

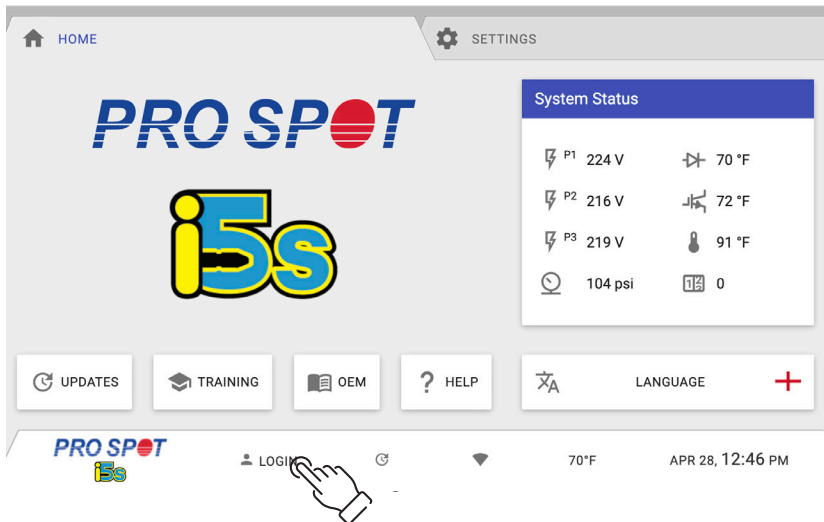

From the Home Screen, touch the Login button to login (Figure 4.5).

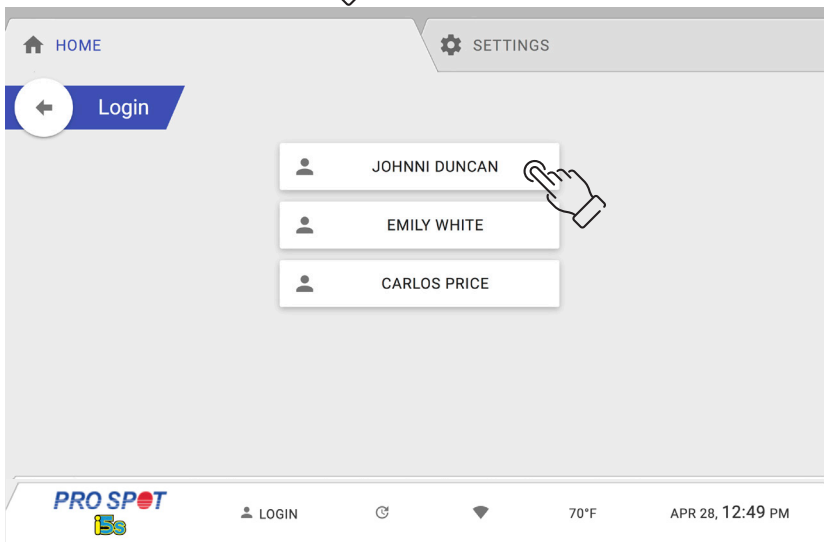

From the Login Menu, select the user account you wish to login into (Figure 4.6).

Figure 4.6

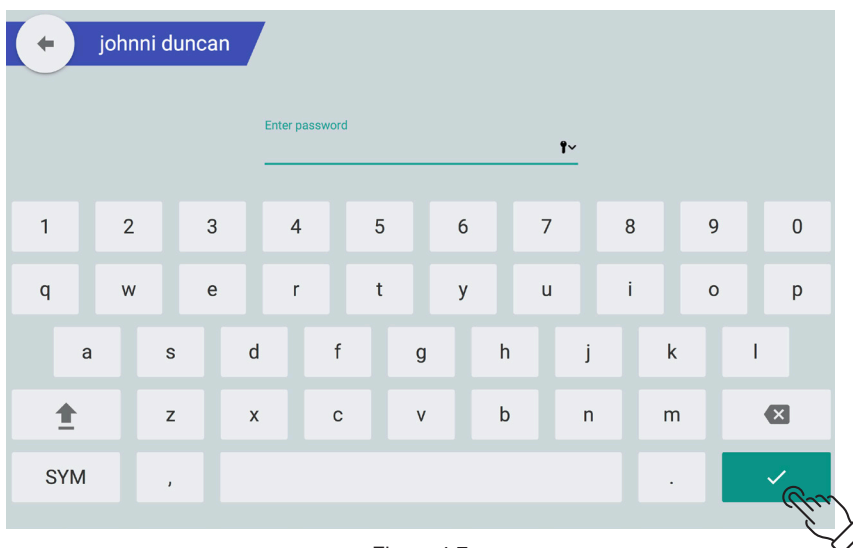

Enter the user password, then press the green check mark to continue to the i5s Home Screen (Figure 4.7).

NOTE: Default user password is - 1234

Figure 4.7

5.3 i5s Home Screen

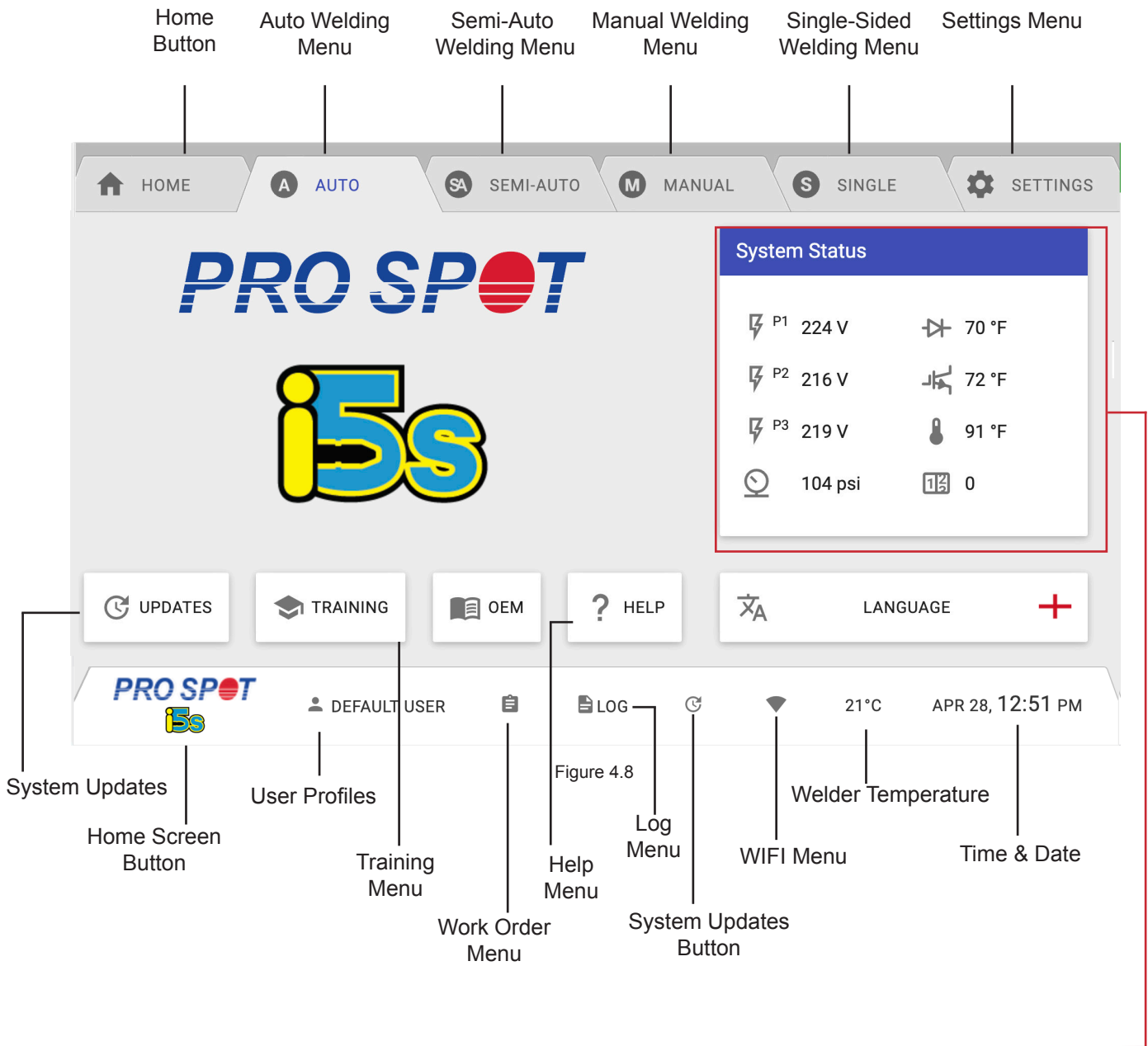

System Status

Phase 1 Voltage	⚡ P1 225 V	🌡️ 21 °C	Diode Temperature
Phase 2 Voltage	⚡ P2 216 V	🌡️ 23 °C	IGBT Temperature
Phase 3 Voltage	⚡ P3 219 V	🌡️ 35 °C	Gun Temperature
Incoming Air Pressure	🕒 97 psi	📅 0	Daily Weld Count

Figure 4.9

5.4 Double-Acting Spot Gun

The spot gun is used for Double Sided Welding programs:
HSS Galvanized Steel, Mild Steel, Weld Bonding, Boron Steel, Pulse Welding, OEM Required Programs and Custom Programs.

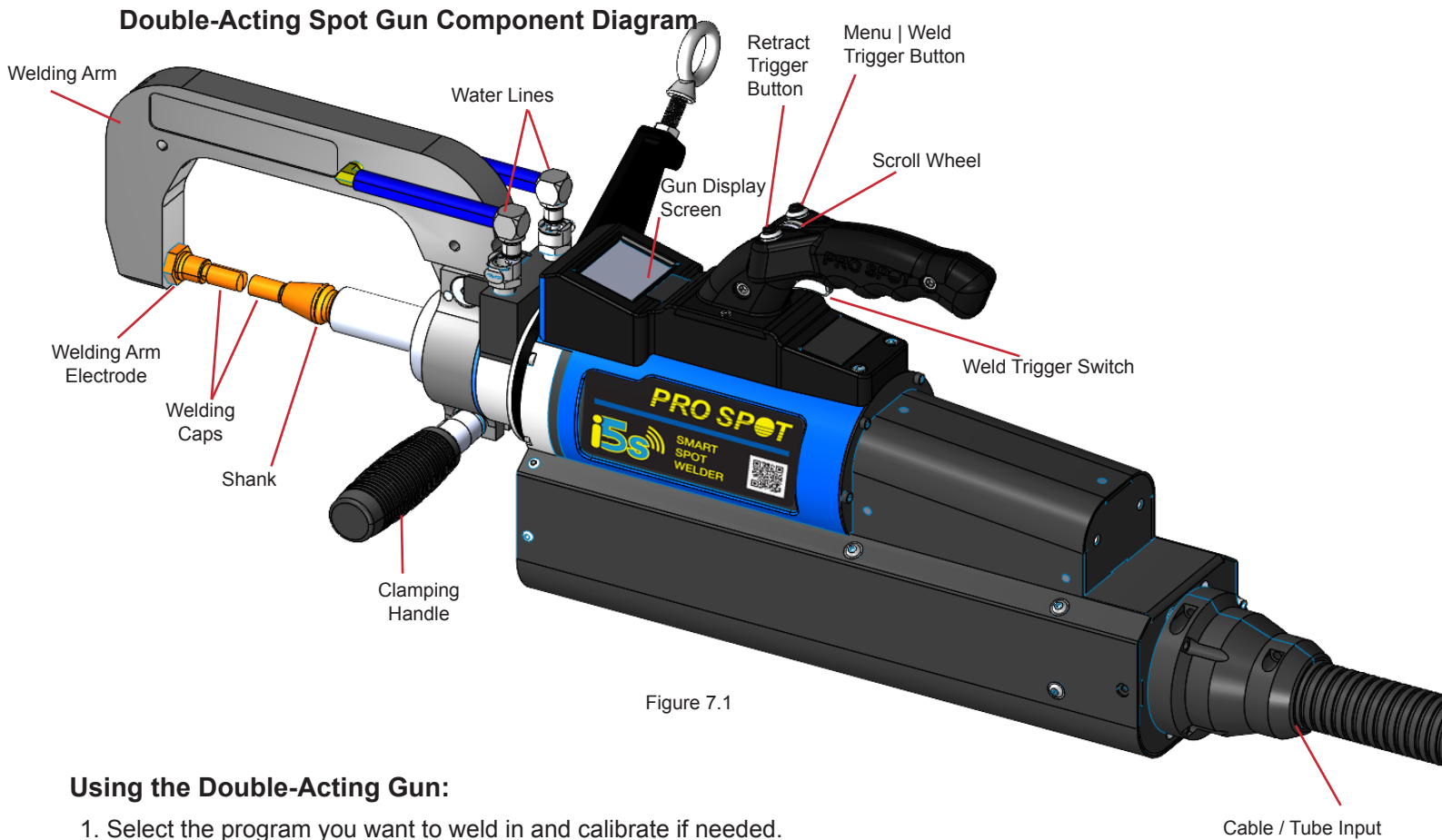
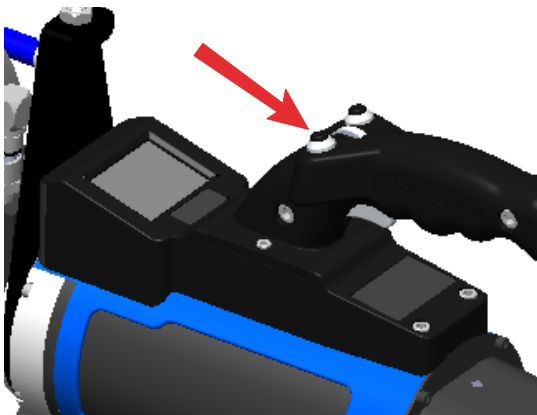

Figure 7.1

Using the Double-Acting Gun:

1. Select the program you want to weld in and calibrate if needed.
2. Bring the weld gun to the material you want to weld or test on.
3. Press the Retract Trigger Button to open the electrodes.
4. Press and hold both, the Weld Trigger AND top right (Menu Trigger) Button to close the gun to weld.



Press and hold the Retract Trigger Button to open electrodes wide completely.

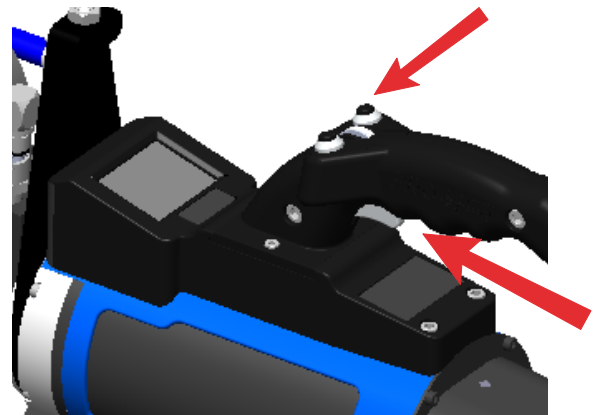

Press and hold BOTH, the Weld Trigger AND top right (Menu Trigger) button on the gun to close electrodes and weld.

5.5 i5s On-Gun Screen & Gun Controls

The i5s gun has an on-gun screen that can show the user exactly which settings and what kind of welds they are producing. This feature gives users the options to make changes to weld settings directly from the gun without needing to go back to the machine.

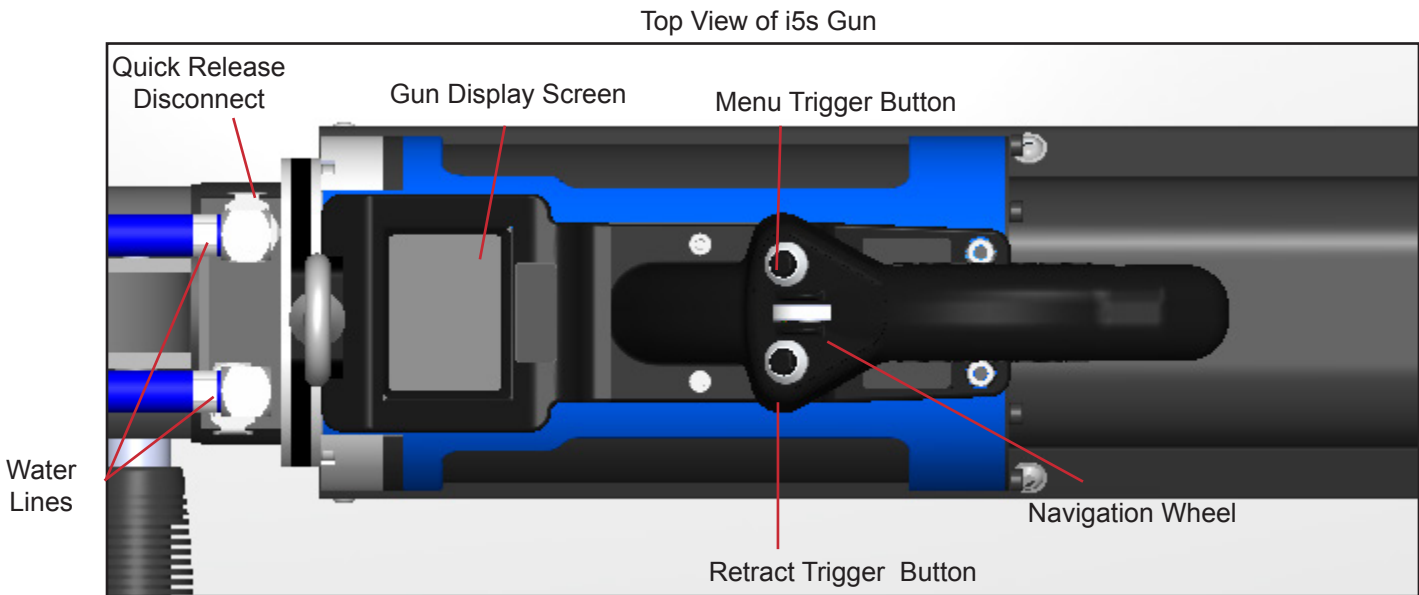

Figure 7.3

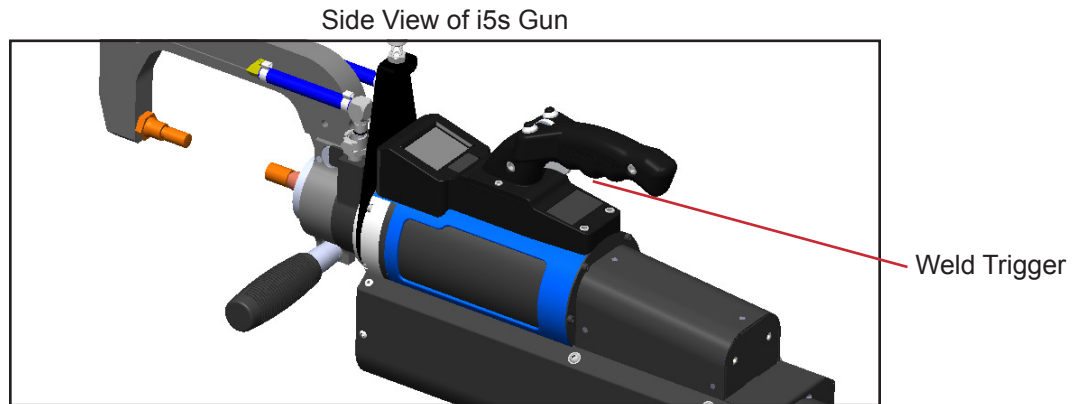

Figure 7.4

i5s Gun Controls

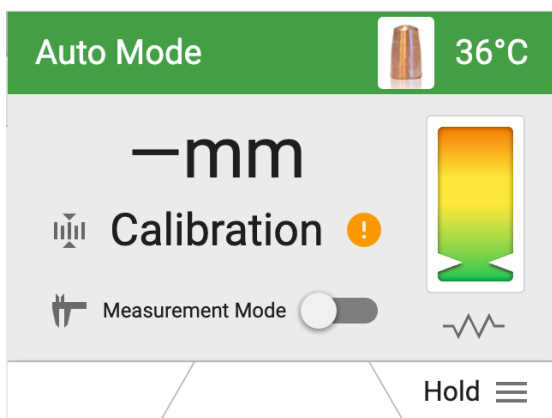

Figure 7.5

The fingertip controls allow the user to calibrate, easily navigate between programs, turn on Measurement Mode and check the results of the last weld.

To access the Options Menu from the gun:

1. You must be in Auto, Manual Mode, Semi-Auto Mode.
2. Press and hold down the Menu Trigger Button on the gun.
3. Use the scroll wheel to pick your selection.
4. Press the Menu Trigger Button to choose your selection.

NOTE: A guide at the bottom of the on-gun screen shows icons indicating the functionality of each button when in the Options Menu.

i5s Gun Screen Displays



Home Screen
Figure 7.6

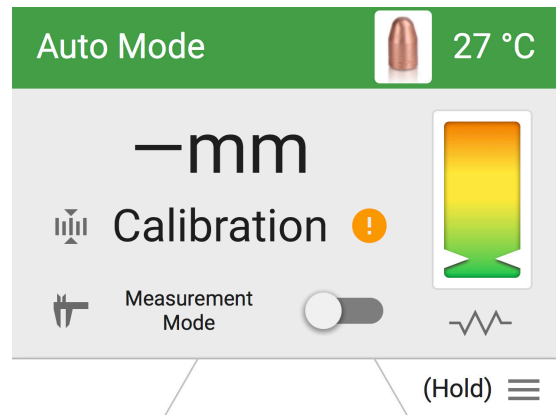

Auto Mode Screen
Figure 7.7

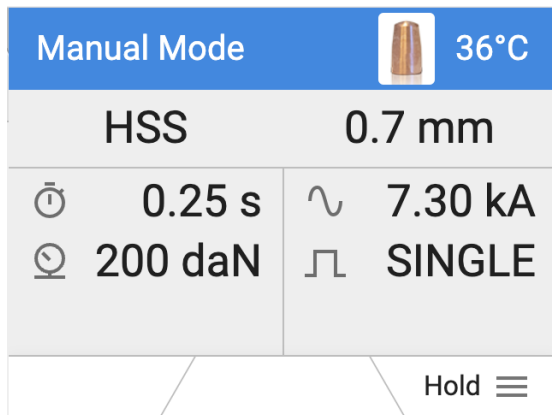

Manual Mode Screen
Figure 7.8

i5s Gun Weld Feedback Screen

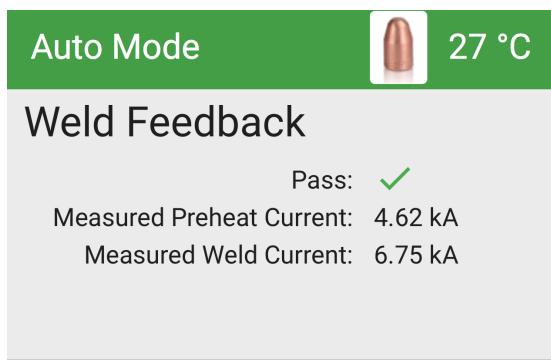

Weld Feedback Screen
Figure 7.10

The Weld Feedback screen will show up on the i5s screen and the i5s gun screen after a weld has been performed. The Weld Feedback screen indicates to the user if the weld passed or failed. It also displays the Measured Preheat Current and the Measured Weld Current.

5.6 Extension Arms

The i5s has a variety of extension arms to accommodate most welding applications.



NOTE: Extension arms marked “optional” are available through your local distributor or online at www.prospot.com.

REMARQUE: Bras d’extension portant la mention «facultatif» sont disponibles à partir de votre Distributeur régional ou en ligne à www.prospot.com

i5s Extension Arms

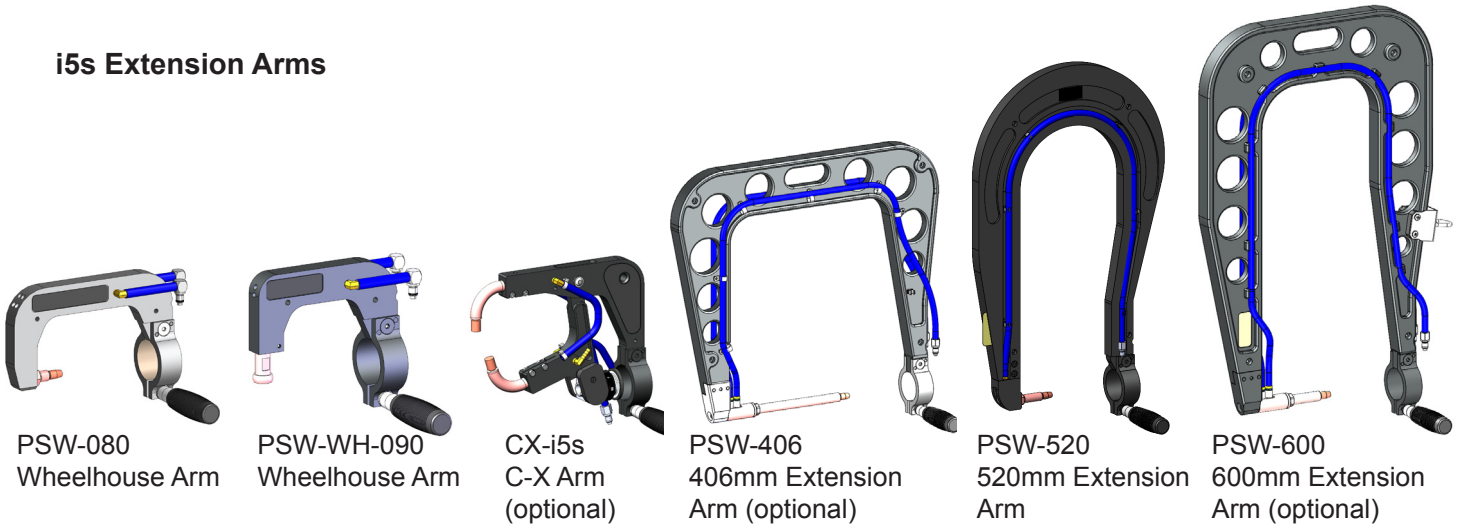

Changing Extension Arms

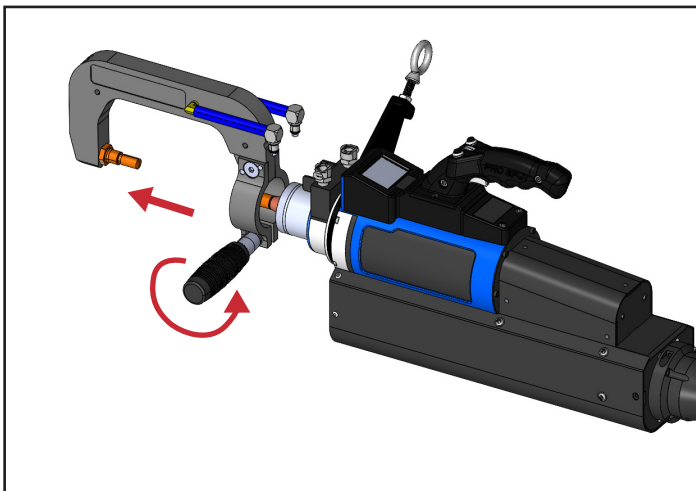
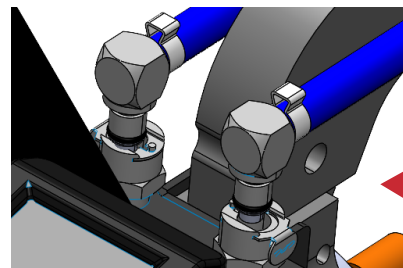

Figure 7.11

How To Change Extension Arms:

1. Make sure the Water Pump is off.
2. Disconnect water lines by pressing release button.
3. Loosen the extension arm handle.
4. Slide the extension arm off.
5. Replace with the arm you want to weld with by sliding it on.
6. Reconnect water lines.
7. Tighten the handle to secure the welding arm..



To remove the water lines: Press the release button on each line.

Figure 7.12



Turn off the water pump before disconnecting water lines. Make sure to properly secure all water hoses before welding.

6.0 i5s General Settings

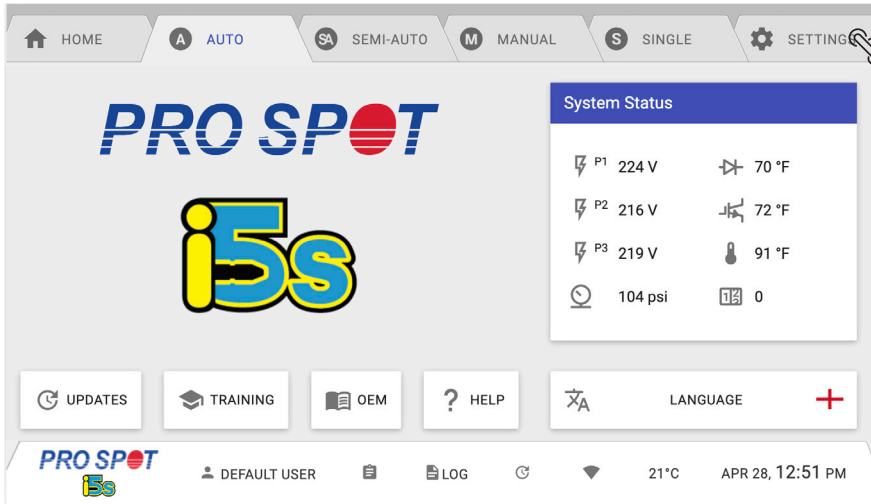

Figure 4.10

To access the i5s System Settings Menu, select the Settings tab on the top right of the screen (Figure 4.10).

6.1 WIFI Menu

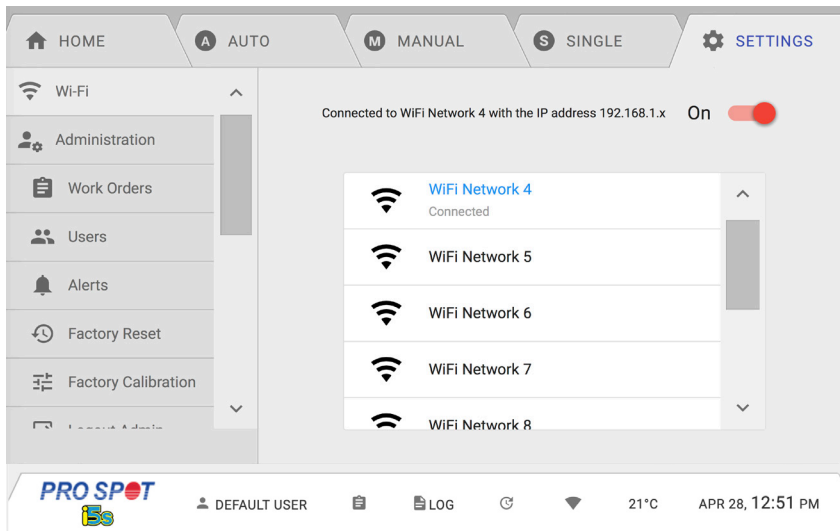

Figure 4.11

The WIFI Menu will let you connect to any wireless network available in your area. Select the network you wish to connect (Figure 4.11).

NOTE: Make sure server is configured to allow access to updates.prospot.com



Figure 4.12

After selecting your network, you will be prompted to enter the network password (Figure 4.12).

6.2 Cooling Menu

The Cooling Menu allows the user to manually configure the air cooling. By default, the single and double-sided air will turn on automatically once the machine reaches a certain temperature. The Single Sided Air slider turns the air for single sided welding on or off. The Double Sided Air slider turns the air for double sided welding on or off. The Water Pump button turns the water pump on or off.

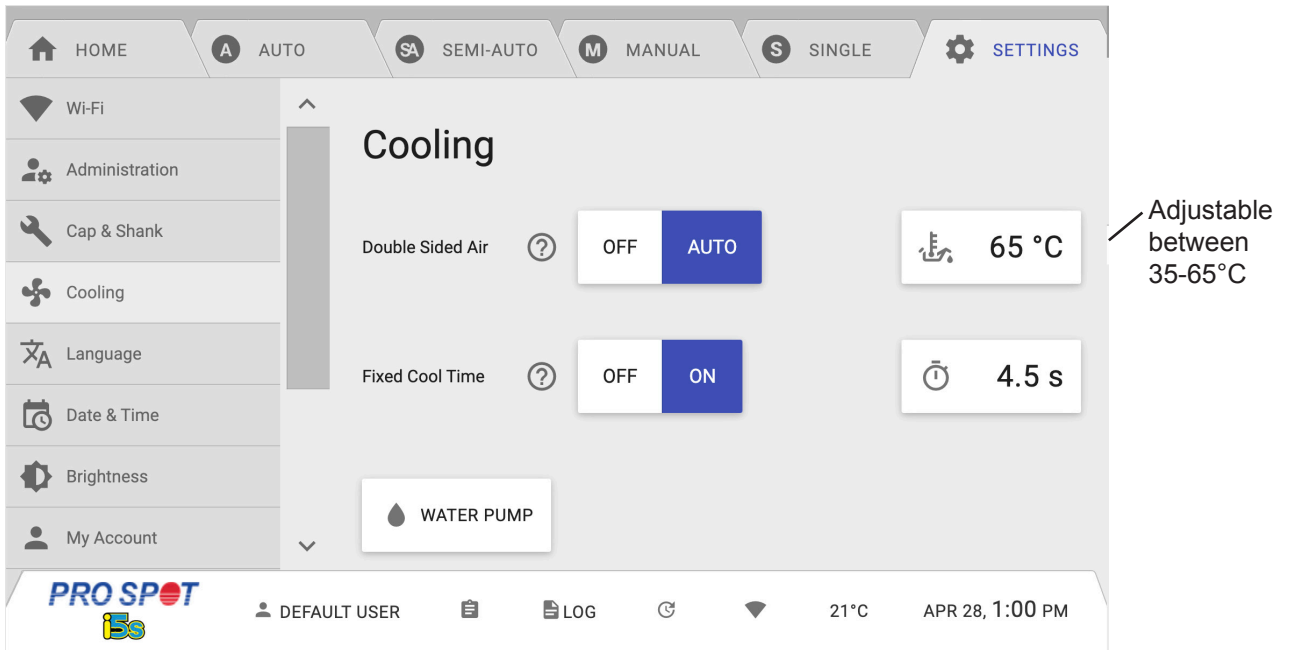

Figure 4.13

Double Sided Air Cooling can be switched on/off manually by sliding the toggle button (Figure 4.13).

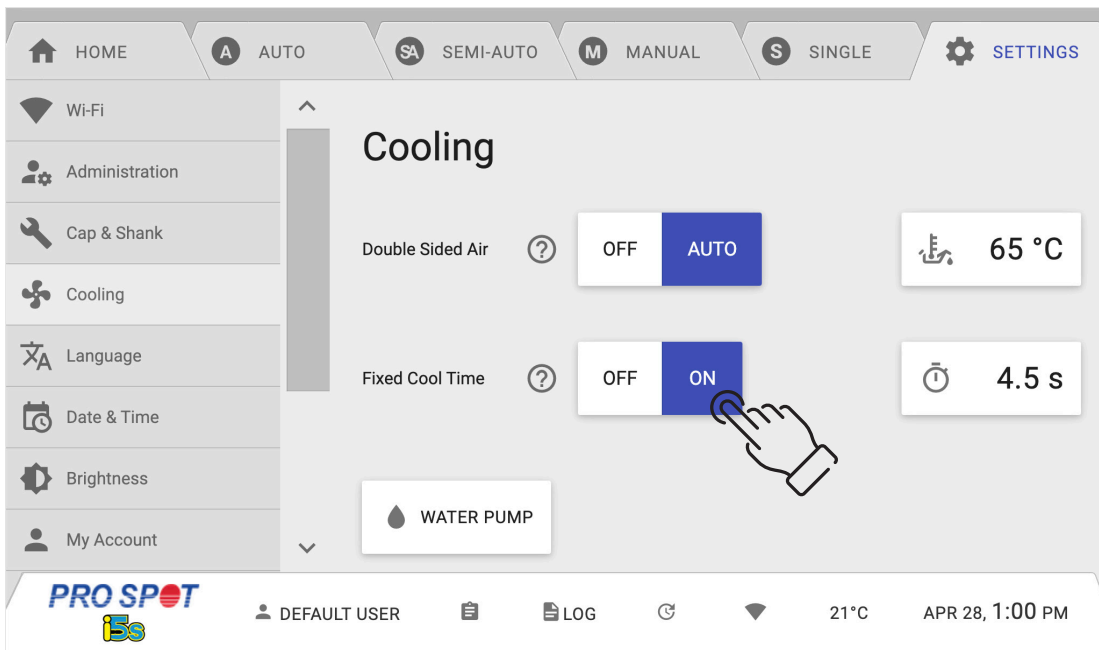

Figure 4.14

By default, the slider is set to the left which mean Optimized Cool Time is active. With Optimized Cool Time enabled, the machine will set the cool time automatically based on several performance-related parameters in order to optimize the duty cycle. When the slider is set to the right, Fixed Cool Time (Figure 14) is enabled and there is a cool time parameter you can set. If the time is set to 4.5s, that means you will need to wait 4.5 seconds after a weld has been completed before you can weld again.

6.3 Date & Time Menu

The Date & Time Menu allows the user to set the time and date. It also allows the user to choose whether they wish to see a 12 Hour or 24 Hour Clock display by selecting the Change Display Unit button (Figure 4.15).

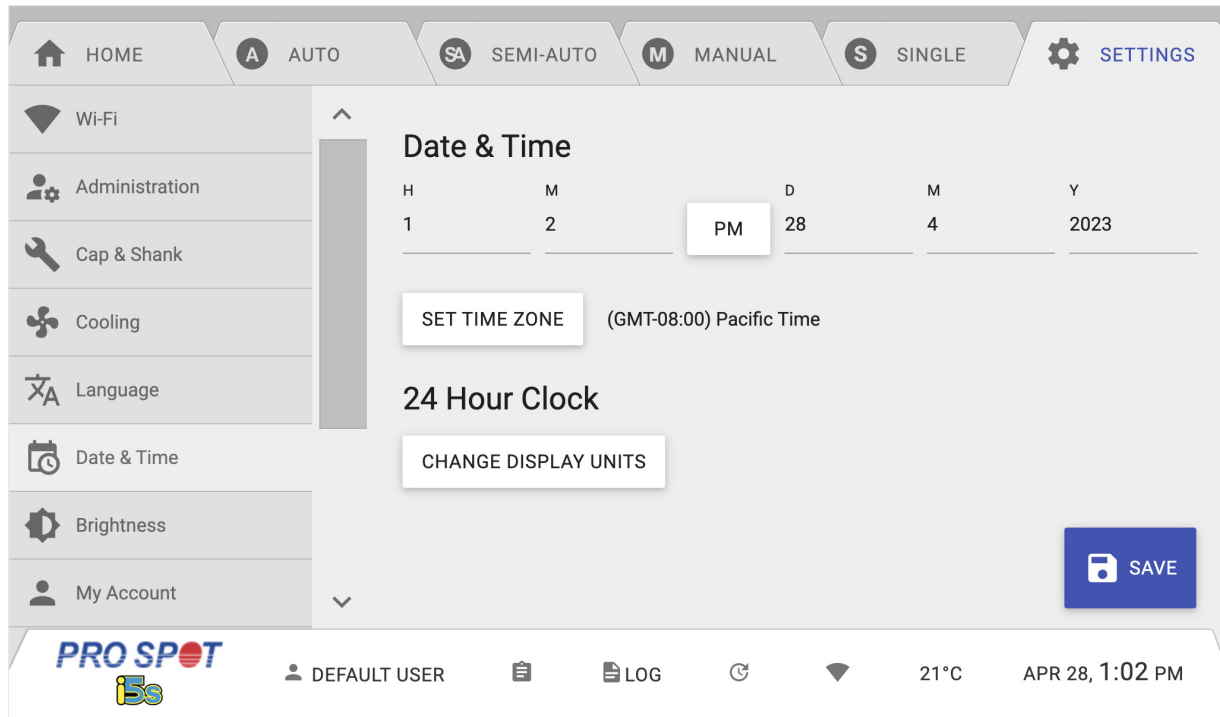
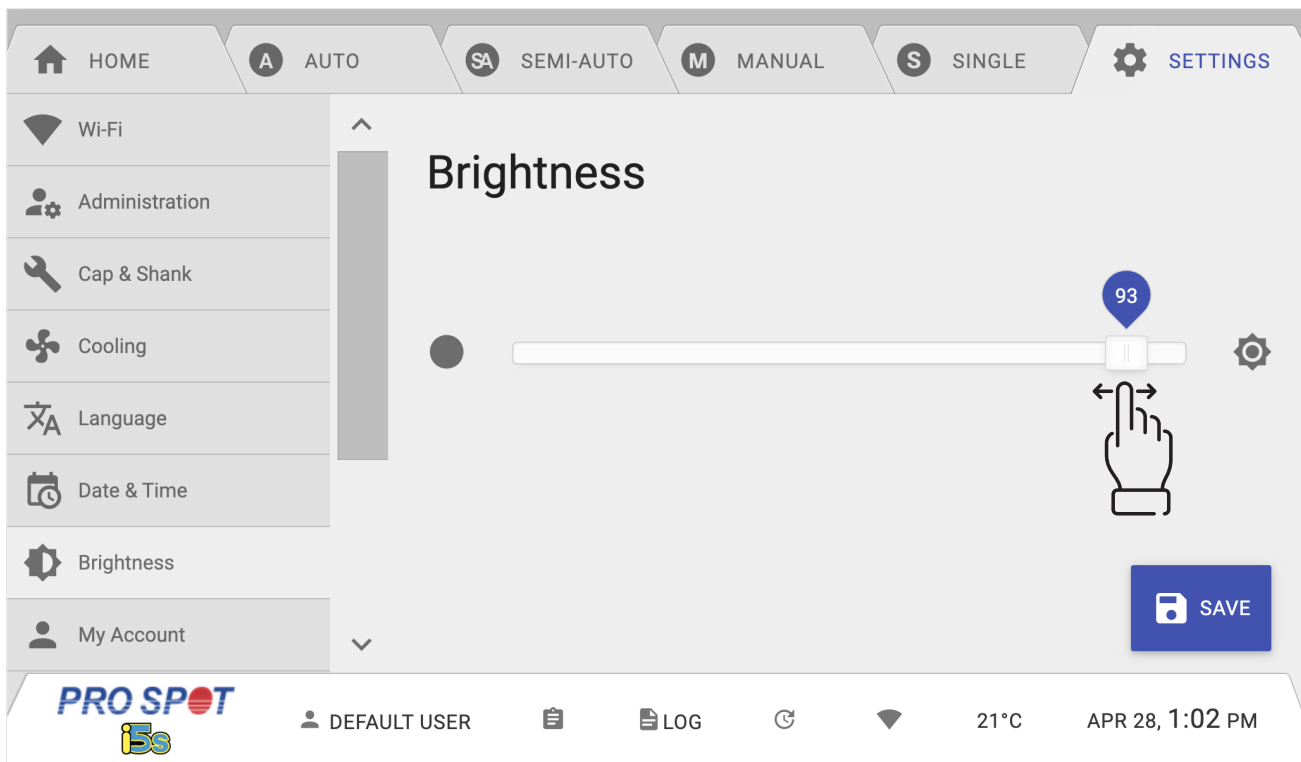

Figure 4.15

6.4 Brightness Menu

The Brightness Menu allows the user to select the brightness level of the LCD screen with a range between 20-100 (Figure 4.16).



6.5 My Account Menu

Under the My Account Menu you will find the Change Password Menu and the Preferences Menu.

Change Password Menu

In the Change Password Menu you are able to change your User Profile Password (Figure 4.17).

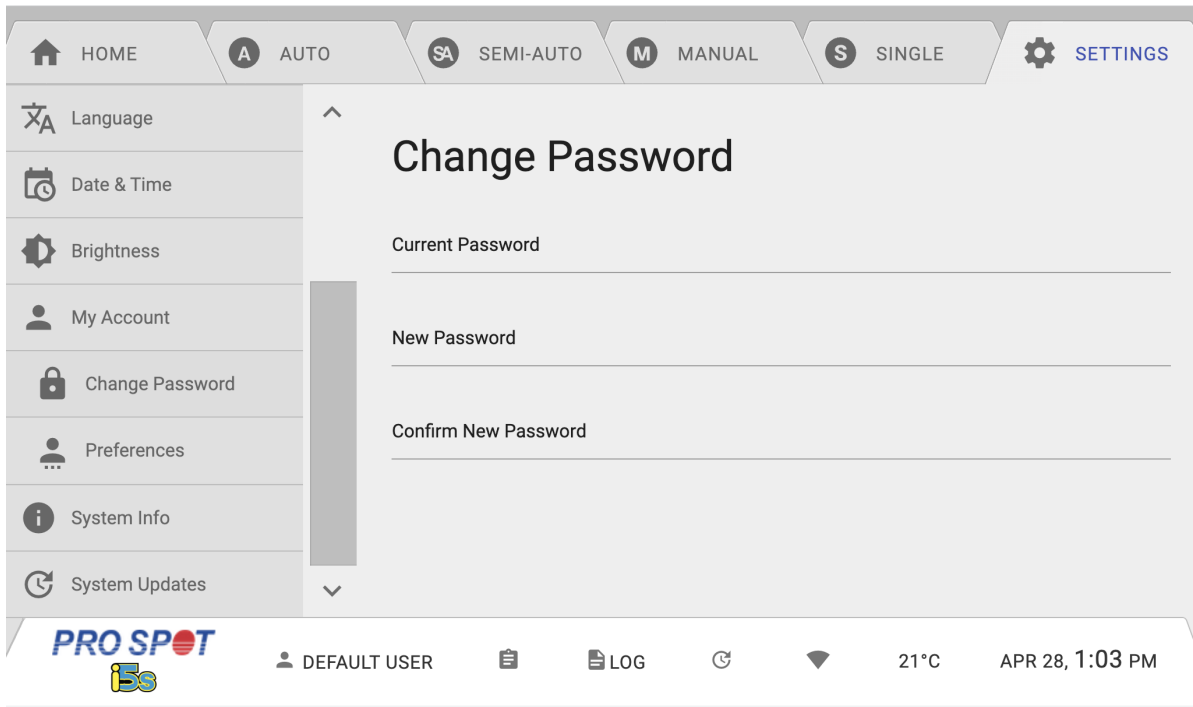

Figure 4.17

Preferences Menu

In the Display Units Menu you are able to change the way the machine displays temperature, Celsius or Fahrenheit, and the clock settings, 12 Hour or 24 Hour (Figure 4.18).

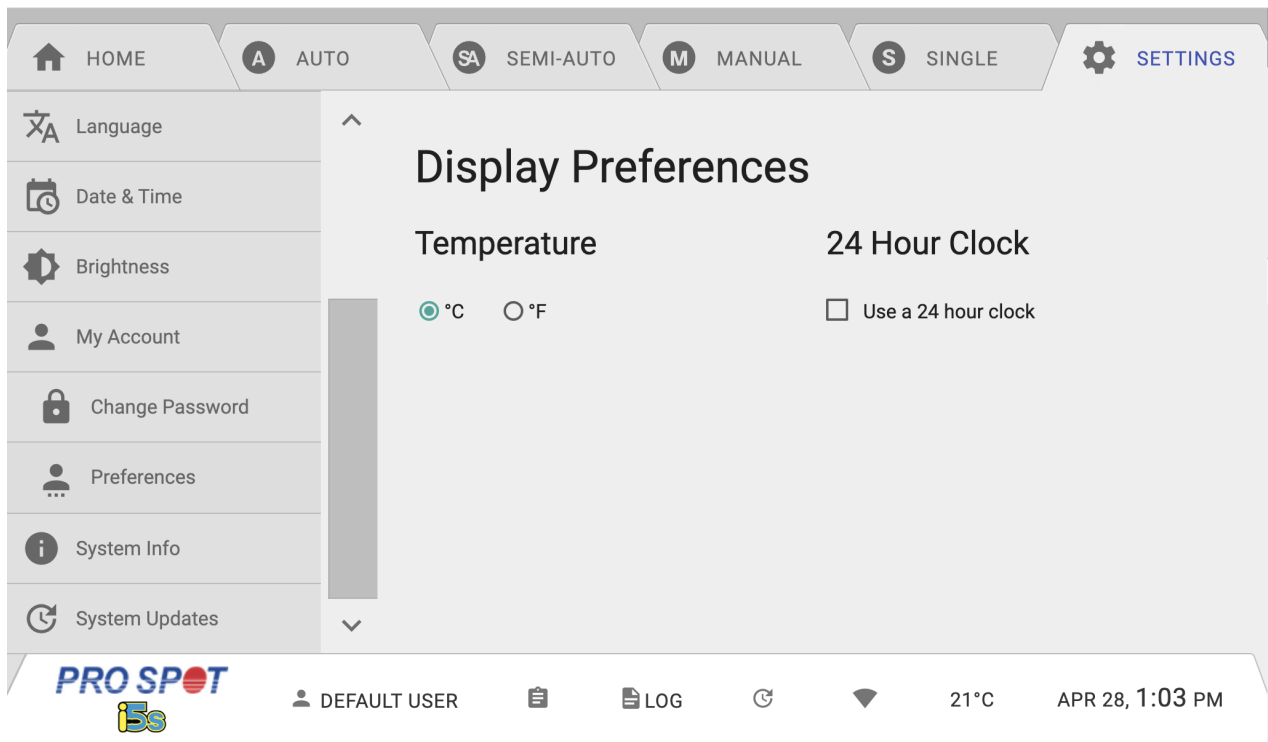

Figure 4.18

6.6 System Info Menu

The System Info Menu displays the hardware versions the machine has. This information may be useful when looking to see if your machine is up to date (Figure 4.19).

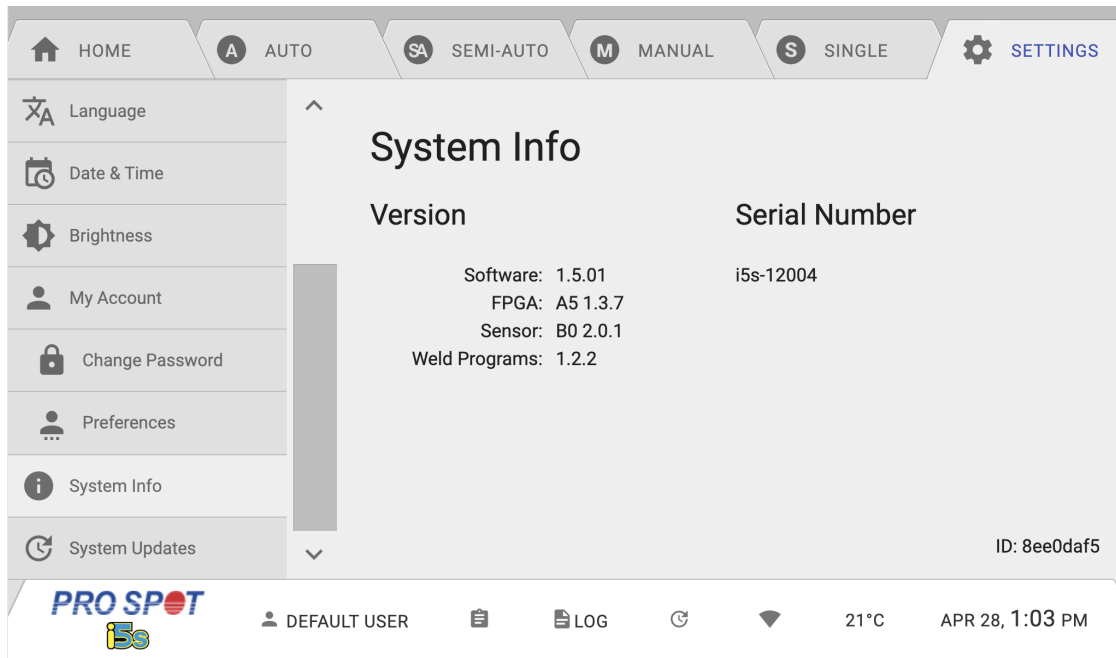

Figure 4.19

System Updates Menu

The System Update Menu allows you to check for software updates and to download the latest updates from Pro Spot. It also displays the Update History of the machine. After the update is done downloading, press the Install Updates button. The machine will automatically reboot and install the new software (Figure 4.20).

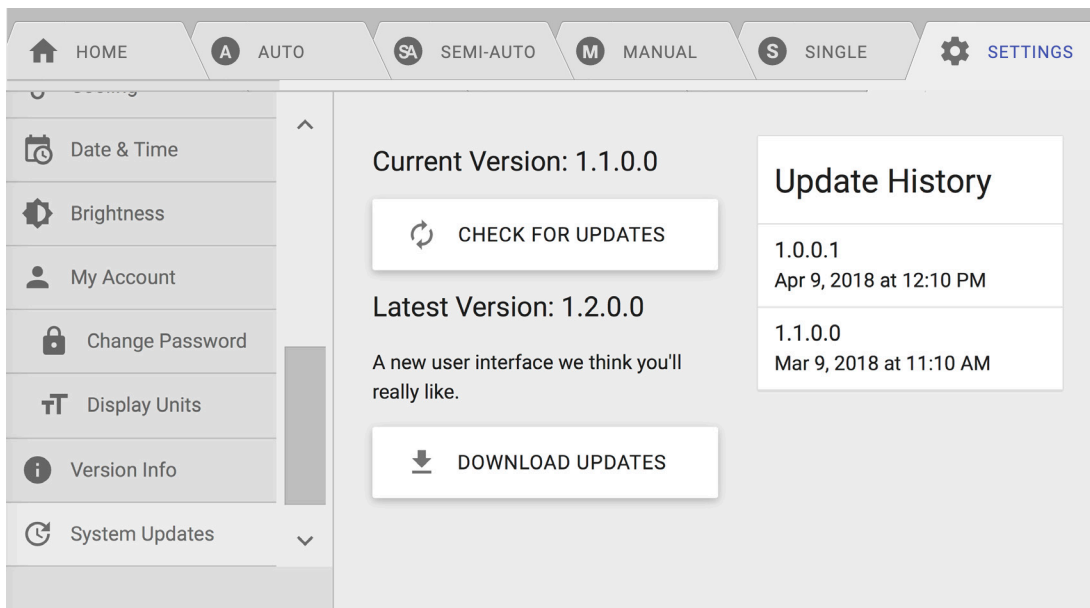

Figure 4.20

6.7 i5s Administration Settings Menus

To access the Administration Settings:

1. Select the Settings tab.
 2. Once you're on the Setting tab, select Administration (Figure 4.21).
 3. Once you see the Administration Menu, you will be prompted with a password screen (Figure 4.22).
 4. Enter the password to get access to the Administration Menus. NOTE: Administration Password: asdf (lowercase)
- NOTE: As a safety precaution, the Administrators access logs out after 2 minutes.

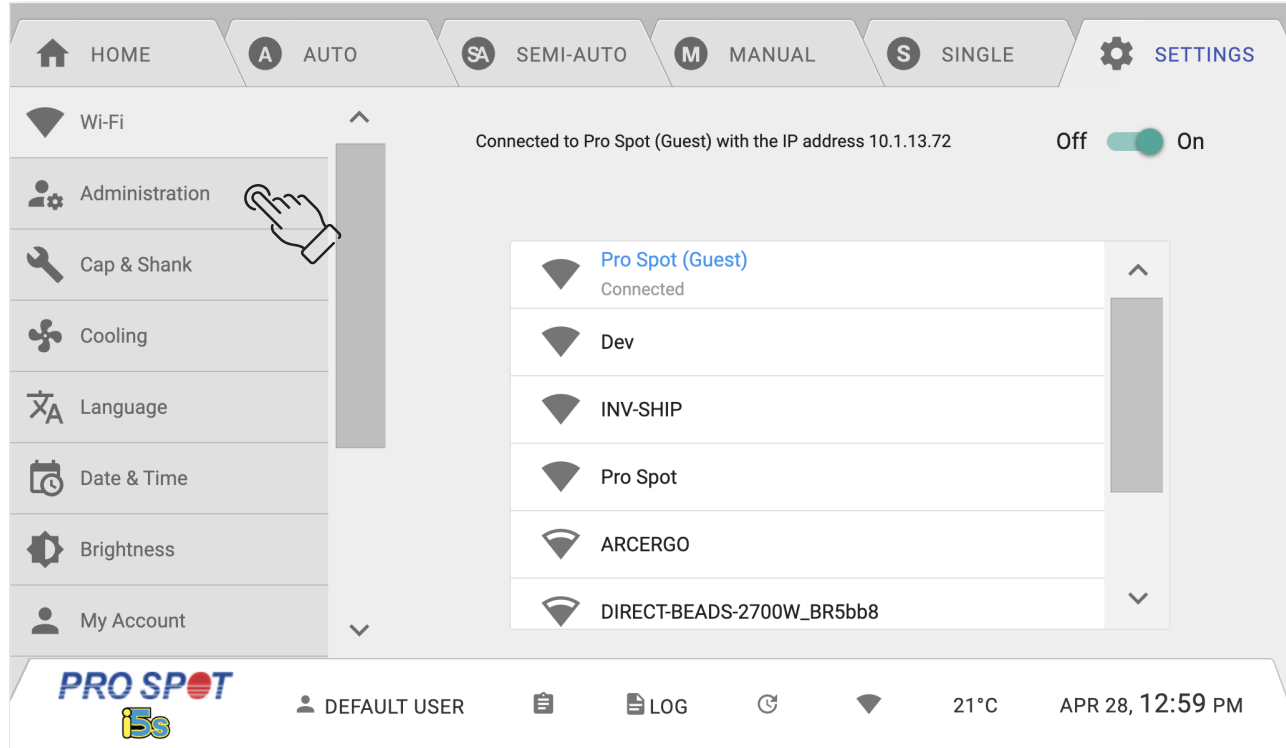

Figure 4.21

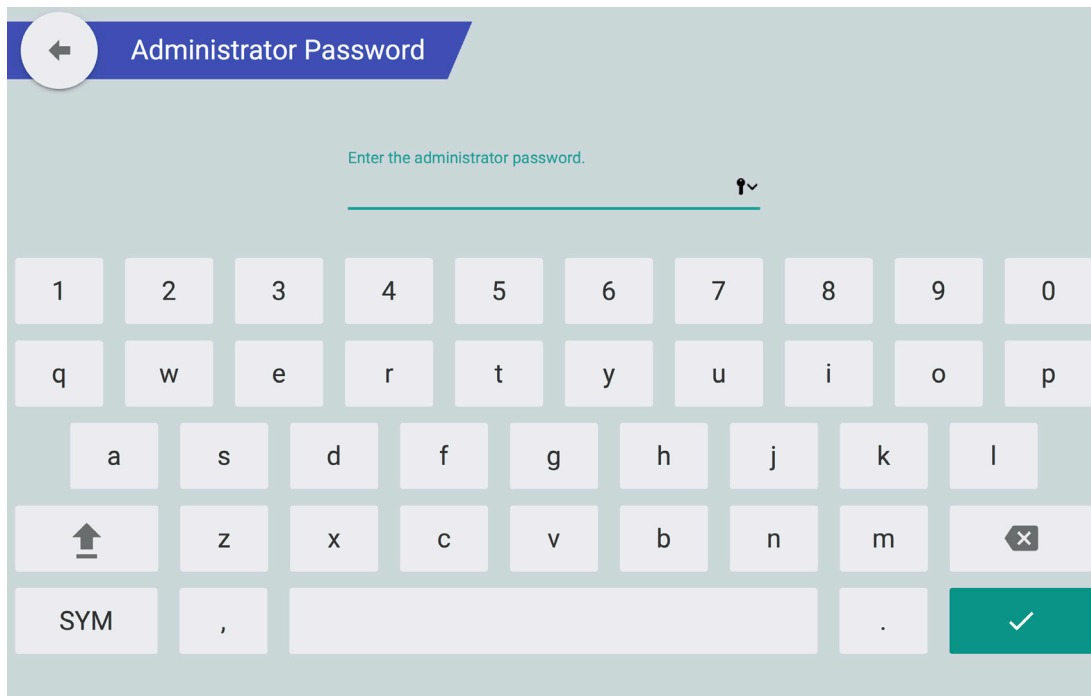

Figure 4.22

6.8 ADMIN: Work Orders

The Work Orders Menu allows you to create work orders which correspond to each individual job. While a work order is active, each weld that is performed will be logged and associated with that specific work order. After creating a work order, it can be assigned to a technician. Once it has been assigned, it will pop up when that technician logs in. When you export the work order, all of the weld information will come with it.

Create A Work Order:

1. The first time you enter the Work Order Menu it will be empty.

NOTE: After entering work orders, the menu will show the previous work orders you have entered (shown below).

2. To create a new work order, select Add New Work Order. This is the red button with a plus sign (Figure 4.23).

3. Once you press the Add New Work Order Button, a menu will pop up and let you enter in the work order information (Figure 4.24).

4. Once you have entered in all the information, hit ADD to continue.

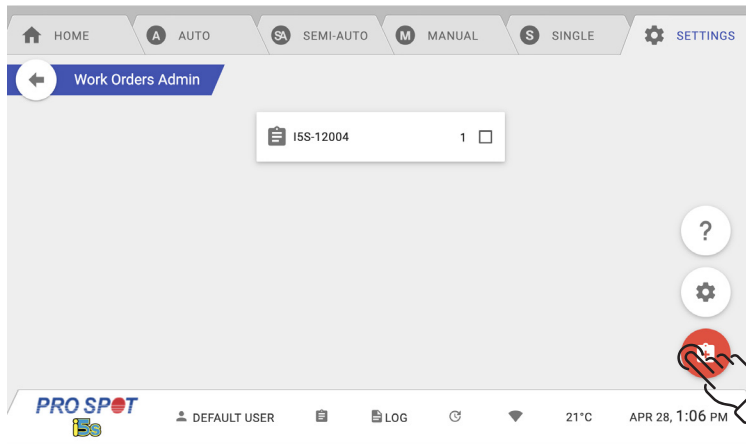

Figure 4.23

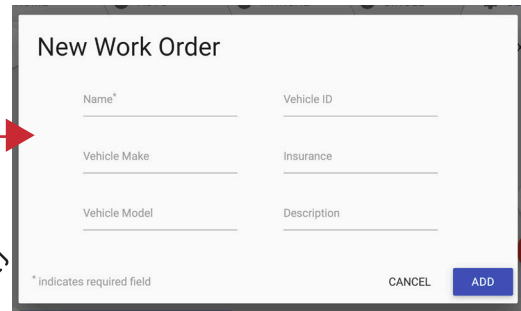

Figure 4.24

Assign A Work Order:

1. To assign someone to the work order, select the work order you wish to assign.

2. On the top right-hand side of the work order you will see four options - Remove, Log, Export and Assign (Figure 4.25).

3. Select the Assign option.

4. From the Users List, select the User you wish to assign the work order to (Figure 4.26).

5. Once you have selected the user, press the button that says Assign.

6. Once they have been assigned, you will be taken back to the Work Order Menu.

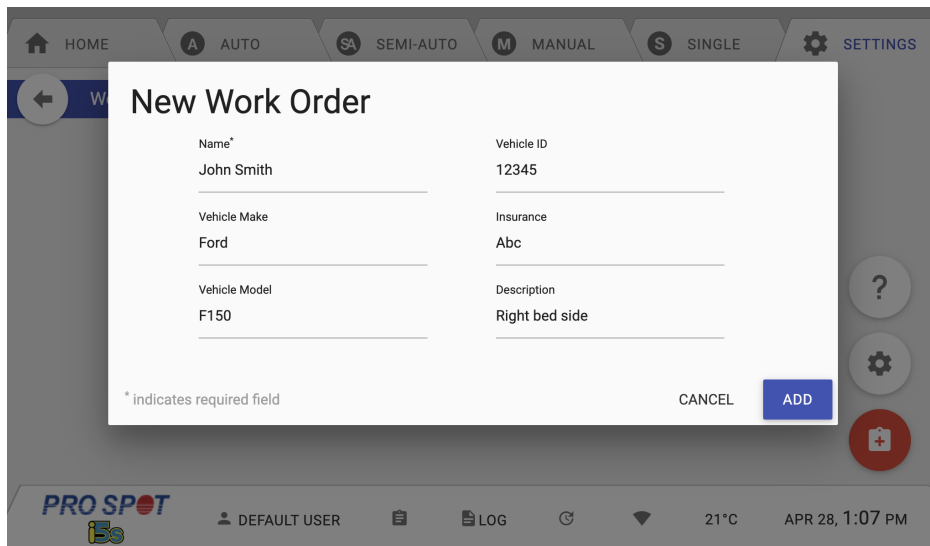

Figure 4.25

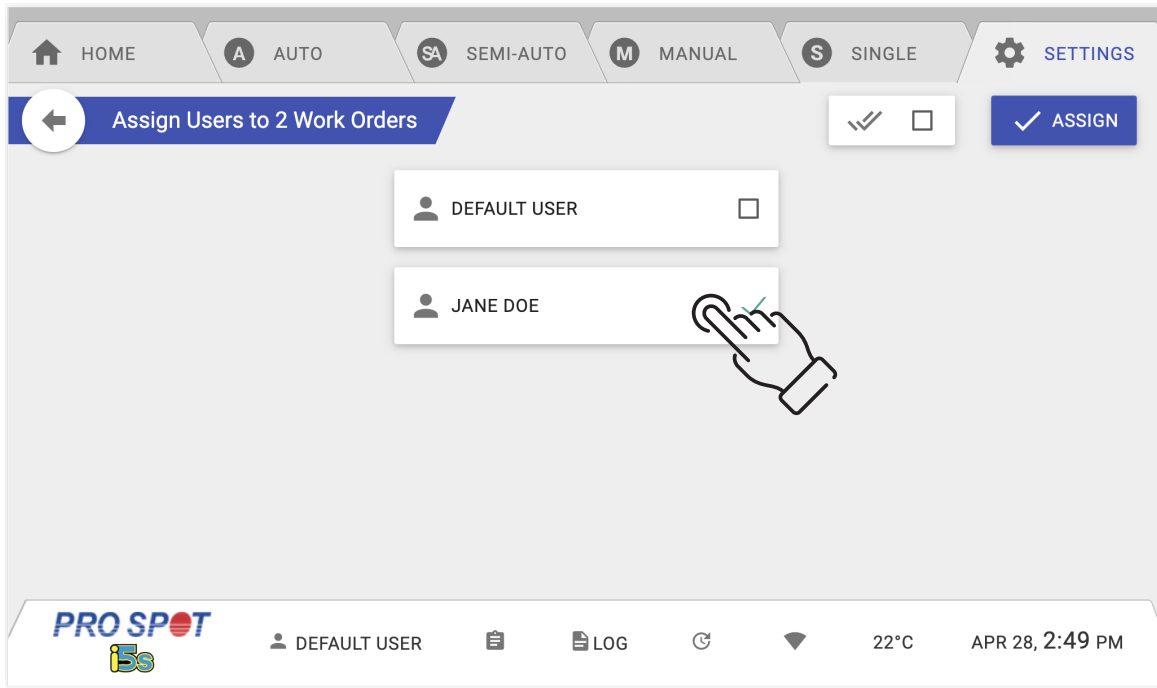

Figure 4.26

Make A Work Order Active:

Make A Work Order Active: Once work orders are assigned to a particular user login, the user would login with their username and then press the W.O. button in the lower status bar. The user will be presented with a list of work orders including the default work order. The green star next to the default work order indicates that the default work order is active (Figure 4.27). When a work order is active, it means that, every weld performed is logged into that active work order. If the user needs to make a different work order active, they simply press the work order they wish to make active and press the Make Active button.

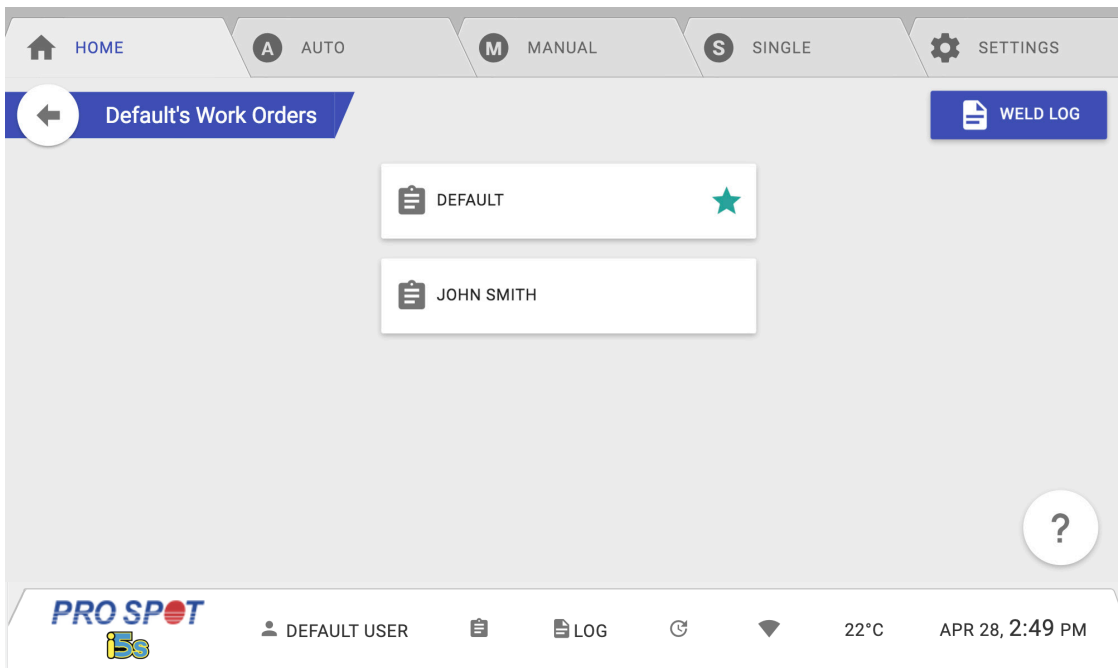

Figure 4.27

Export A Work Order:

Once the work order has been completed, the information can be exported via Email or USB.

1. Select the work order you wish to export from the Work Order Menu and press Export in the top-right.
2. Once you press the export button you will be taken to the Export Work Order prompt (Figure 4.28).
3. You have two choices on how to export the work order: Export to Email and Export to USB.
4. Select your option and export.
5. If using the Export to Email option, the Select Email button takes you to a list of previously entered emails, or you can manually enter any email address then Export. **NOTE:** WiFi must be turned on and connected to email weld logs

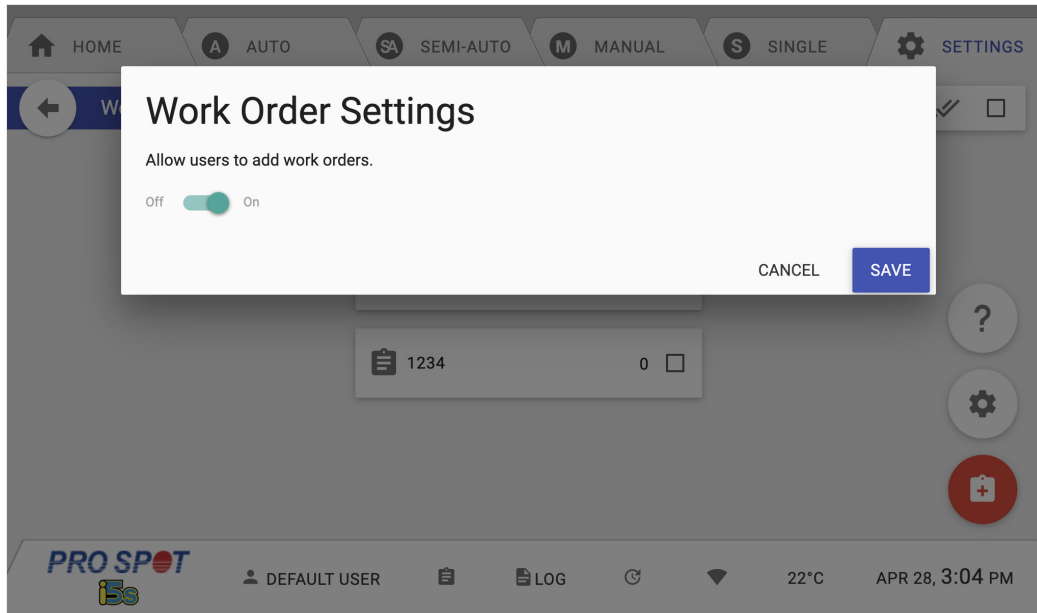

Figure 4.28

How To Allow Users To Add Work Orders:

1. Navigate to the Work Orders Admin Menu (Figure 4.29).
2. Select the Settings Button located above the Add Work Order Button.
3. This will bring up the Work Order Settings (Figure 4.30).
4. To select the option to allow users to add work orders, toggle the button to the right (it will turn green) and press the Save Button (Figure 4.32). To turn off the option, toggle the button to the left.
5. Now when users access the Work Orders Menu they will also have the option to add work orders. You can see if this feature is activated by the red Create Work Order Button located on the bottom-right. (Figure 4.32).

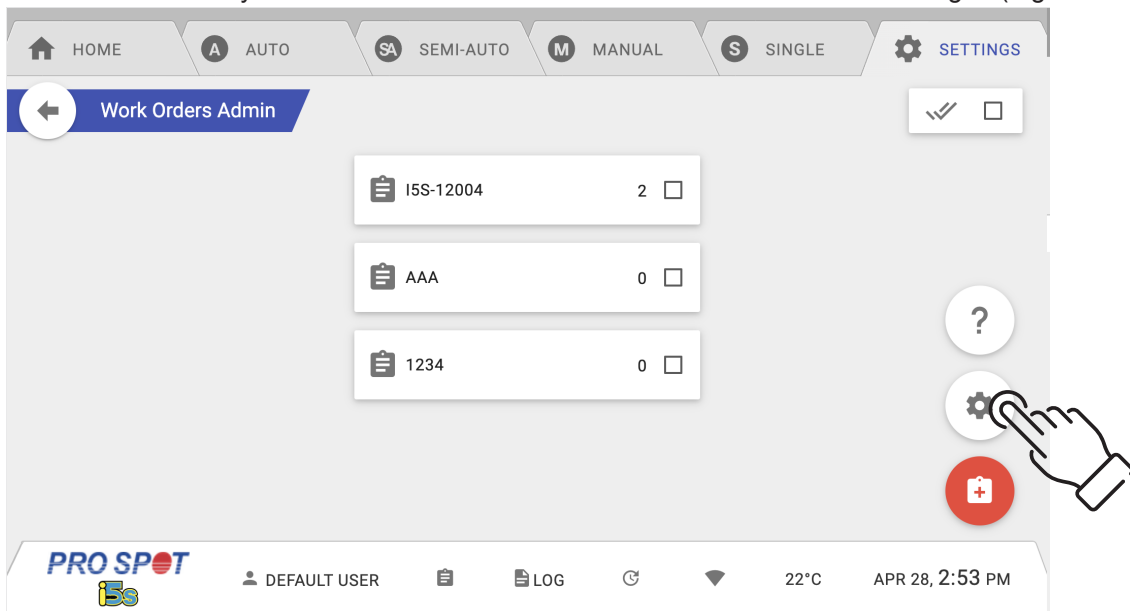

Figure 4.29

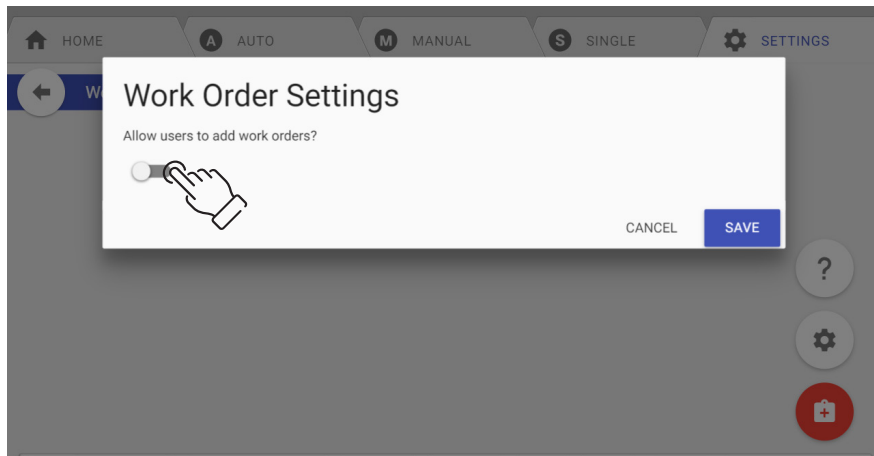

Figure 4.30

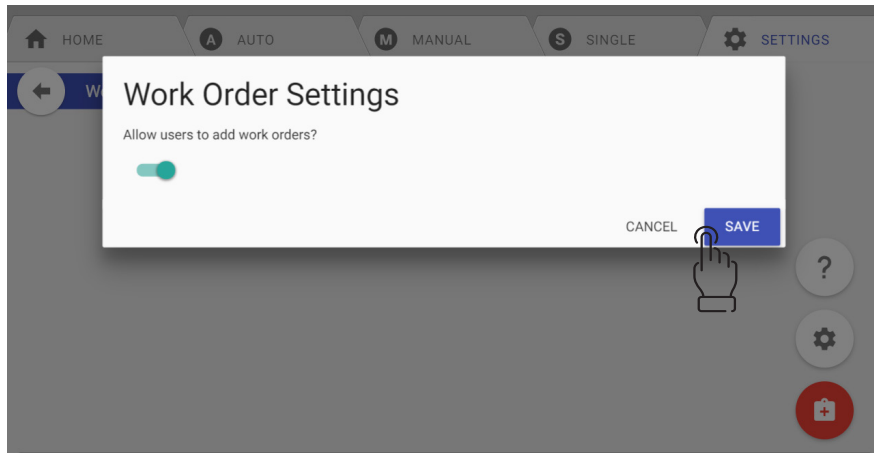

Figure 4.31

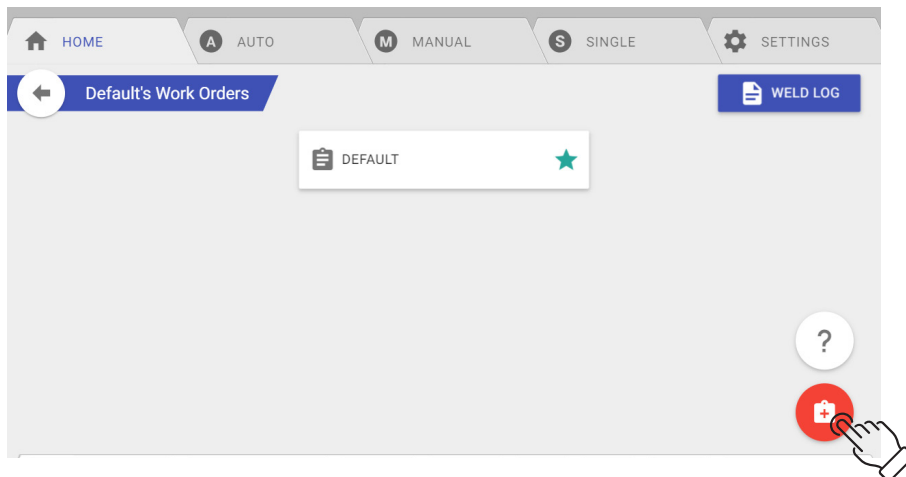

Figure 4.32

6.9 ADMIN: User Menu

In the User Menu, the Administrator can add, edit and remove user profiles.

Add A New User:

1. Navigate to the User Menu and select the red Create User Button in the bottom right (Figure 4.33).
2. Once you select Create User, a new user prompt will pop up and ask you for the New User details (Figure 4.34).
3. Enter the user's information and determine their user level - Basic, Standard or Advanced. Then press the Add button to add the user.

Basic User Settings: Not permitted to change any advanced settings.

Standard User Settings: Permitted to change advanced settings.

Advanced User Settings: Permitted to change Auto Mode advanced settings. Not recommended for normal users.

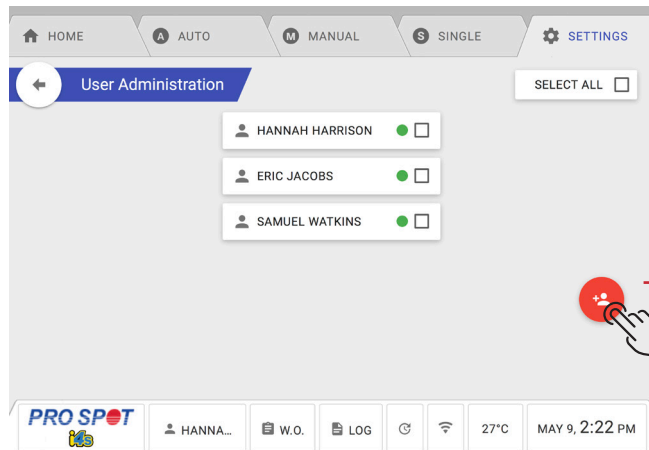

Figure 4.33

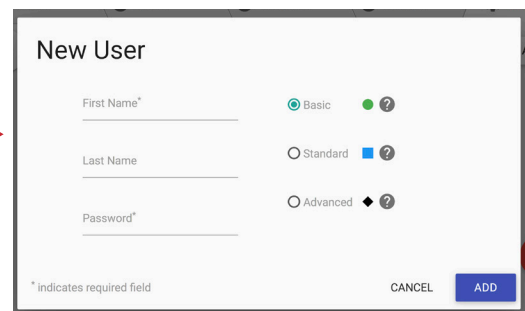

Figure 4.34

How To Edit or Remove A User Profile:

1. Navigate to the Users Menu and select the user you want to edit or remove.
2. The Edit User Menu will pop up (Figure 4.35), where you can edit or remove the profile.

Edit a User Profile:

1. Select any field you wish to edit.
2. Once your edits are done, hit save.

Remove a User Profile:

1. Press the Remove User button located on the top right-hand side, then hit save.

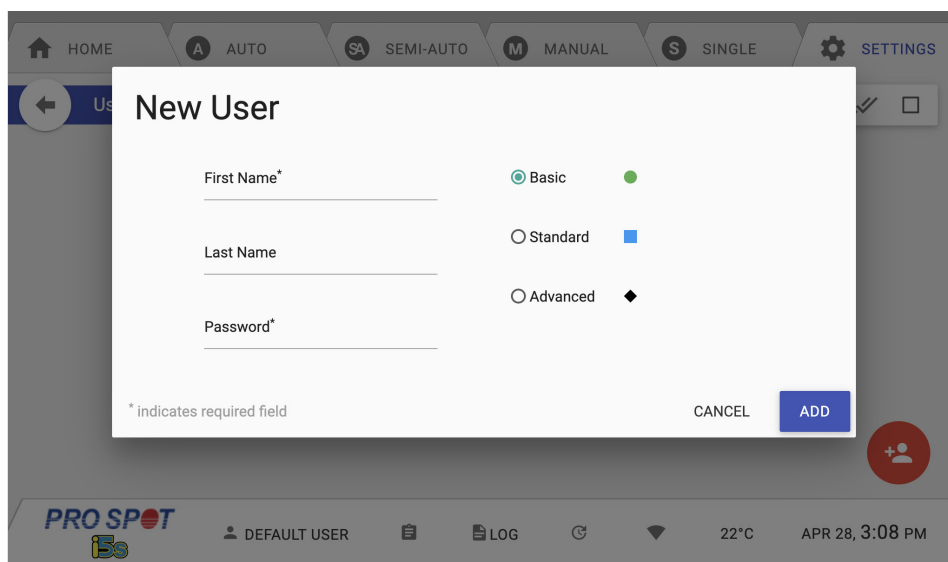

Figure 4.35

Alerts Menu

The Alerts Menu allows users to adjust the Current Tolerance, Idle Line Voltage and Weld Line Voltage (Figure 4.36). Transformer Temperature is the temp in which welder goes into cool down mode once the welder reaches that temperature. Adjustable between 70-105°C.

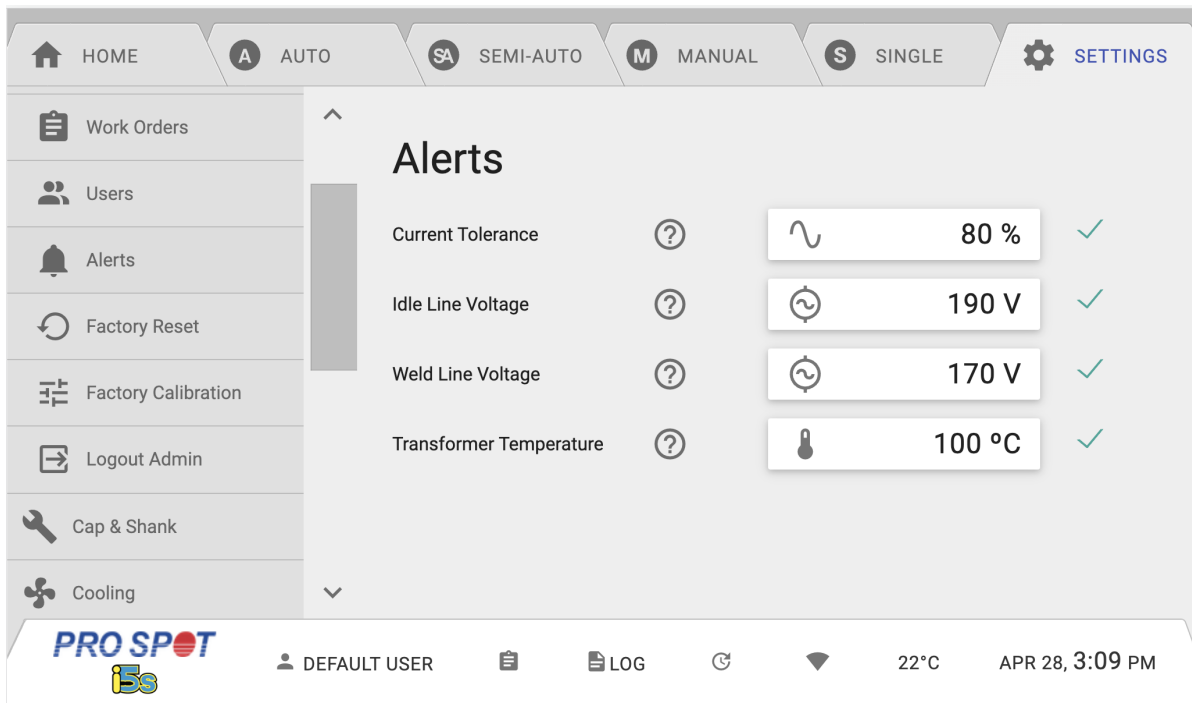

Figure 4.36

Factory Reset Menu

The Factory Reset Menu will give you the option to reset weld programs, user preferences, system alerts and a complete factory reset (Figure 4.37).

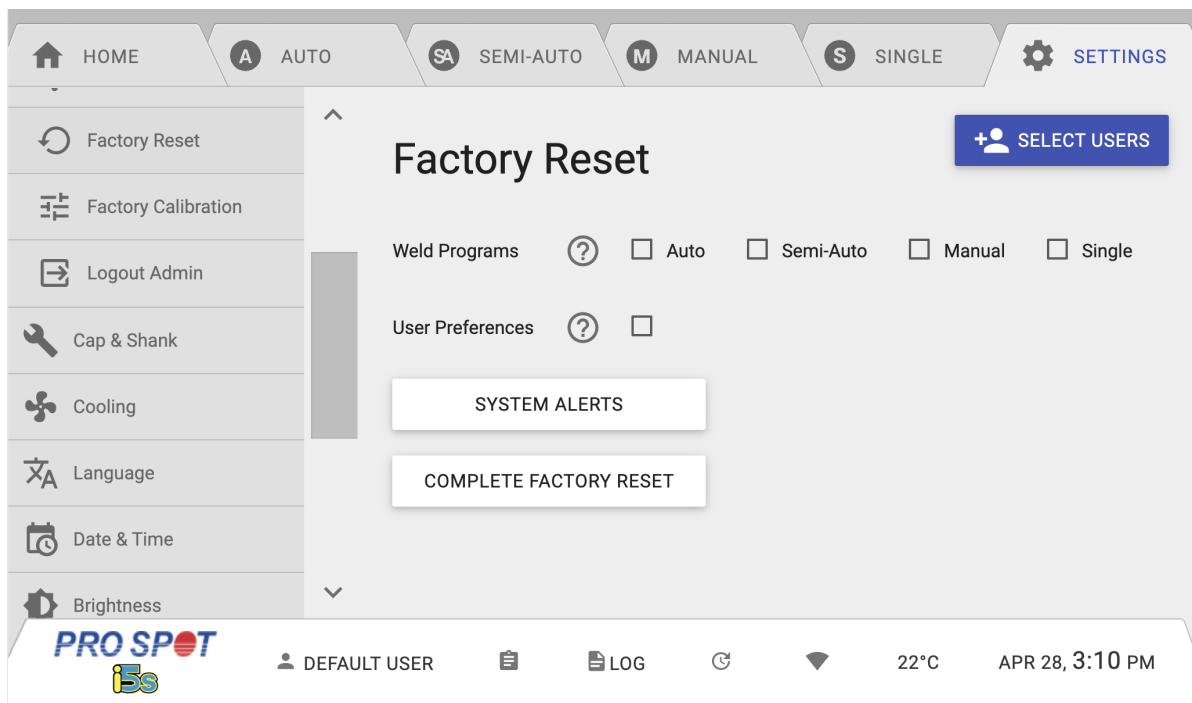

Figure 4.37

To Reset:

1. Select the feature you wish to reset.
2. Once you have selected one of the options listed above, press the Reset button.

IMPORTANT:

Complete factory reset should only be performed after consulting Pro Spot Technical Support. Performing reset will erase all valuable weld log data.

- Checking the Auto check box resets all of the Advanced Auto Weld Settings to Factory Default for the selected users.
- Checking the Manual check box resets all of the Advanced Manual Settings and material presets to Factory Default for the selected users.
- Checking the Single Sided check box resets all of the Advanced Single Sided Settings and single sided adapter programs to Factory Default for the selected users.
- Checking the User Preferences check box resets all of the User Preferences settings for the selected users.

The Select Users button allows you to select which users you want the Factory Reset to affect. You can either select specific users by pressing each user or you can select all users by pressing Select All. Selected users will have a green checkmark next to their name. Once you have chosen the users, press the Select button to confirm your selection.

After configuring the Factory Reset options, you can press the Reset button to perform the Factory Reset.

There are also 2 other reset options: System Alerts and Complete Factory Reset. Pressing the System Alerts button resets the Alerts settings under the Administration menu in Settings. Pressing the Complete Factory Reset button restores the welder to factory defaults and should only be performed when instructed to do so by Pro Spot International Technical Support team.

Factory Calibration Menu

The Factory Calibration provides the ability calibrate the machine to optimal performance. This should only be performed by authorized Pro Spot personnel.

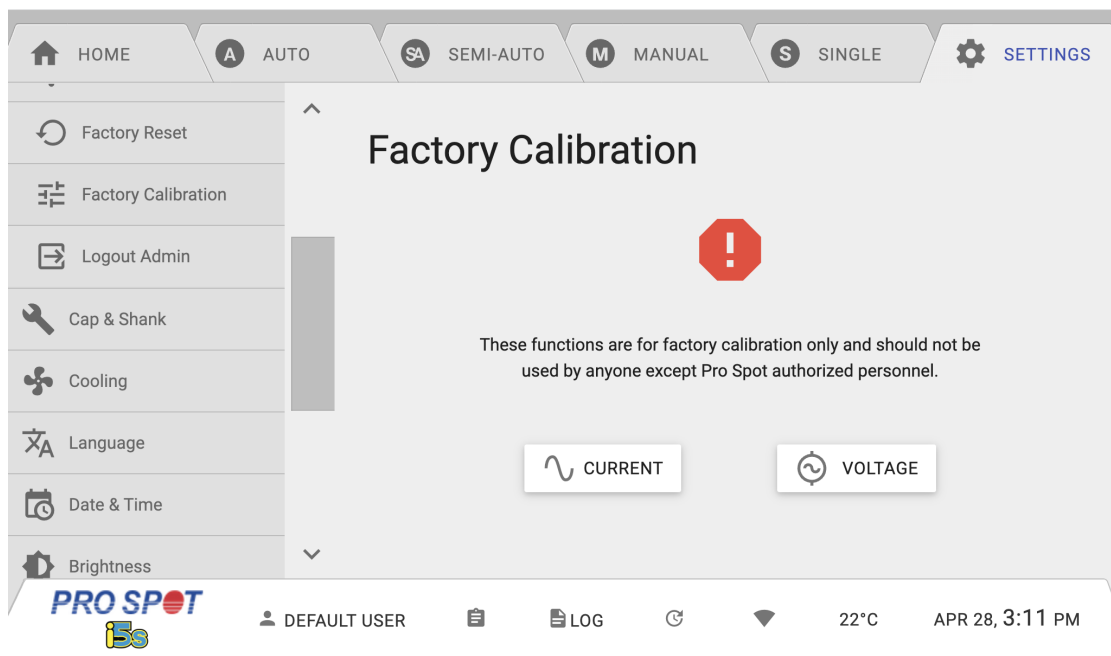

Figure 4.38



WARNING! These functions are for factory calibration only and should not be used by anyone other than authorized Pro Spot personnel.

Voltage Calibration

The Voltage Calibration will help users measure the AC voltage between phases with a multimeter. This should only be performed by authorized Pro Spot personnel.



WARNING! These functions are for factory calibration only and should not be used by anyone other than authorized Pro Spot personnel.

7.0 Auto Mode

Auto Mode on the i5s automatically detects the thickness and resistance of the weld stack up. Once properly calibrated, the user only needs to press and hold the weld trigger and the top right button on the gun and the i5s will determine the correct weld power, weld time and squeeze pressure.



IMPORTANT! Make sure the extension arm water cooling hoses are securely clipped into place before welding.

IMPORTANT! The i5s welder comes without coolant to ease transportation, be sure to fill the coolant tank before turning on the welder.

IMPORTANT! If the thermal breaker has tripped and shut off the welder, please contact Pro Spot's authorized service personnel.



IMPORTANT! N'éteignez pas le soudeur pendant que le système de refroidissement est activé!

IMPORTANT! Si le disjoncteur thermique a éteint le soudeur, s'il vous plaît contactez personnel de service autorisé Pro Spot.

7.1 Auto Mode Menu Guide

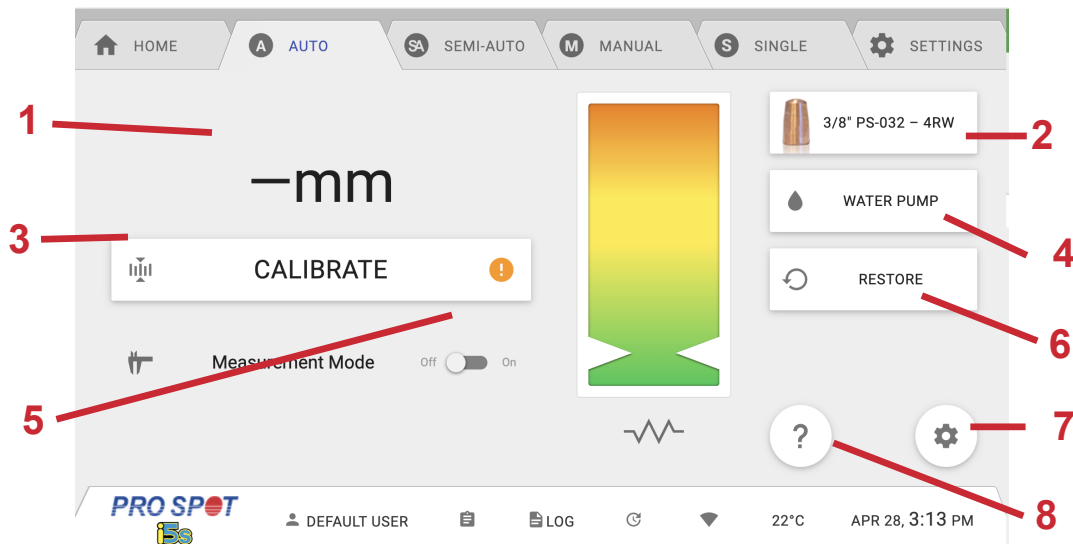
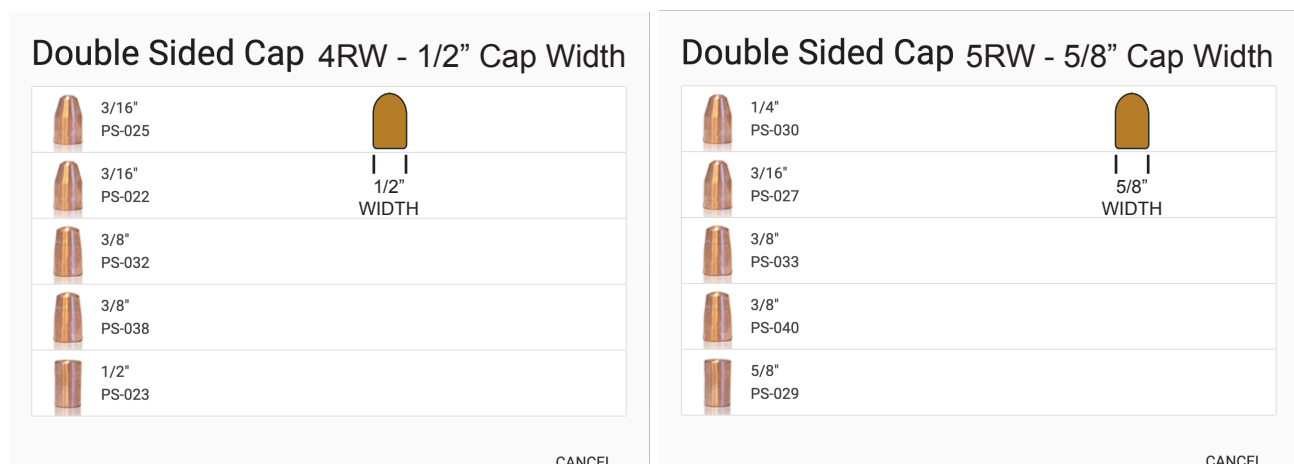

Figure 5.1

1. Thickness Measurement - This displays the thickness in millimeters of the material between the tips when welding.



3. Calibrate - This button starts the calibration process which is necessary in order to use Auto Mode. Follow the on-screen instructions to calibrate. You will need to do this in the following scenarios:

- a. every time you enter Auto Mode
- b. when a weld cap is changed and the weld cap setting is changed
- c. when an arm is changed
- d. periodically as your weld caps get more worn
- e. every 100 welds
- f. any time you notice the thickness measurement is not accurate
- g. every time you go away from the Auto Weld screen and go back to it.

4. Water Pump Shutoff - This button allows the user to temporarily disable the water pump so that an arm or weld caps can be changed on the double side weld gun. Refer to section 7.2 for changing arms and section 8.1 for changing weld caps before doing so. The screen will prompt a countdown for you to wait, after it expires, you can turn the water pump back on after necessary changes have been made. After the change is complete, you can press DONE to continue and the water pump will turn back on.

5. Measurement Mode - This slider toggles the welder between Auto Weld Mode and Measurement Mode. The slider in the Figure 5.2 is in Auto Weld Mode. When pressed, it will slide to the right and turn green. A message will show up on the screen notifying the user that they are now in Measurement Mode. Measurement mode applies a small current through the workpiece allowing the machine to measure the thickness without welding. To return to Auto Weld Mode, simply press the slider again.

6. Restore Button - This button will restore your weld settings.

7. Auto Weld Advanced Settings - This button allows the user to change the parameters that affect Auto Mode. You will need the admin password in order to access these settings. **WARNING:** Contact Pro Spot technical support before modifying any of these settings.

8. Auto Weld Help - This button shows the user help information that applies to the Auto Weld screen.

7.2 Auto Mode - Measurement Only Mode

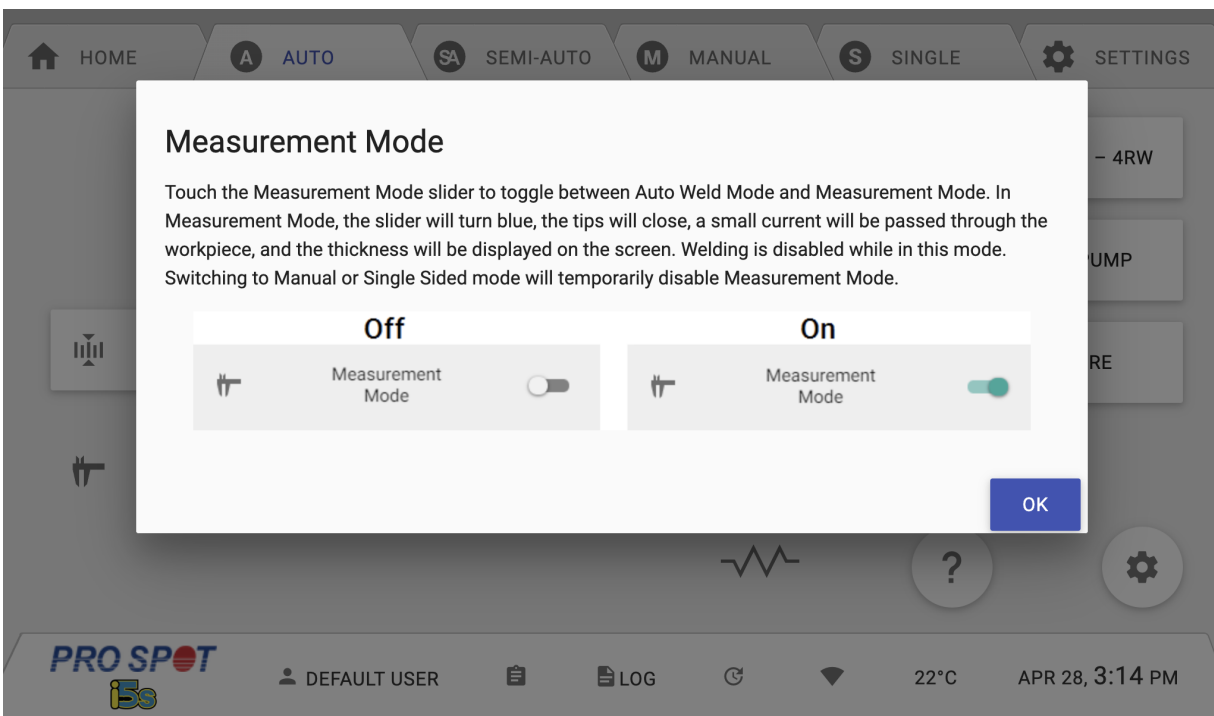

Figure 5.2

The user can also access the Auto Mode screen to select Measurement Only Mode, which measures the steel thickness and resistance without welding (Figure 5.2).

7.3 Auto Mode Calibration

Auto Mode Calibration zeroes out the measurement system to prepare it for an Auto Weld. Start the Calibration process by pressing the Calibrate button on the screen.



1. Press and hold the Release Trigger Button to open electrodes wide. NOTE: if the gun physically open all the way, the screen will prompt you to go to step 2.

2. Press and hold both, the Weld Trigger and top right button on the gun to close electrodes.

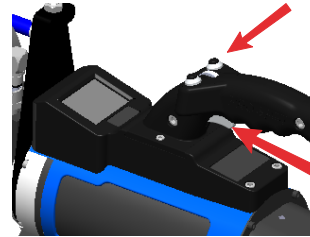
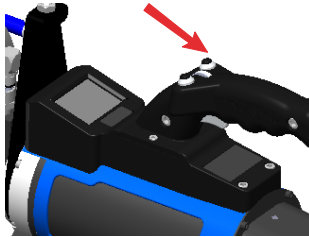

Be sure to calibrate in Auto Mode:

- Every 100 welds
- Every arm exchange
- Every time Auto Mode is entered
- You can NEVER calibrate too often!

After each weld, the measured thickness feedback will be displayed on the screen (Figure 5.3).

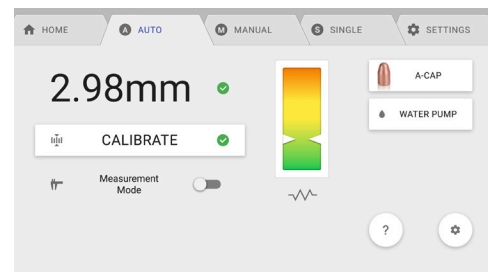

Figure 5.3

After a weld has been completed, the Weld Feedback screen will appear.

- If the weld was performed correctly, you will automatically return to the Auto Weld screen.
- If there was a was a problem with the weld, the screen will display what went wrong.
- Follow I-Car Uniform Procedures For Collision Repair WE51S Squeeze-Type Resistance Spot Weld and always perform routine test welds followed by destructive testing.

Settings:

The Settings button can be used to modify Auto weld settings. Only users at the advanced and expert levels are permitted to access Weld Mode settings.

WARNING: It is NOT recommended that factory settings be modified.

Measurement Only Mode:

The Caliper icon sets the i5s to Measurement Only Mode. While in Measurement Only Mode, the Caliper icon will be highlighted in green.

Measurement Only Mode allows you to measure the thickness and resistance of steel without welding it.

8.0 Manual Mode Welding Menu Guide

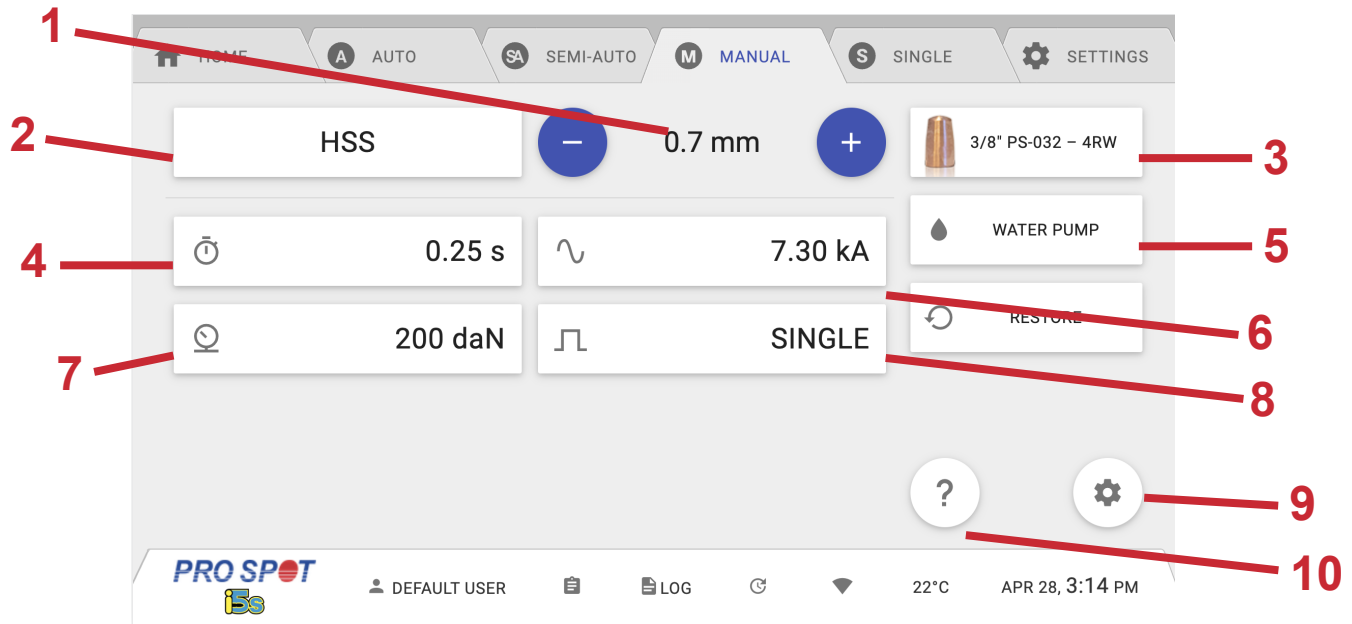

Figure 5.4

1. Weld Thickness - This button provides selection of 6 different weld thickness (0.7, 1.0, 1.2, 1.5, 2.0, 2.5 mm). The thickness setting is chosen by the thickest layer in your weld stackup. Remember: Satisfactory weld settings are always determined by vehicle OEM instructions and destructive testing.
2. Weld Material - This button provides selection of 4 different materials (HSS, Mild Steel, Weld Bond, Boron, Custom, Honda) as well as a Custom setting for you to create your own presets.
3. Weld Caps selection: 4RW (PS-025, PS-022, PS-032, PS-038, PS-023) and 5RW (PS-030, PS-027, PS-033, PS-040, PS-029).
4. Weld Time - This button allows the user to adjust the amount of time that the welder provides current.
5. Water Pump Shutoff - This button allows the user to temporarily disable the water pump so that an arm or weld caps can be changed on the double side weld gun. The screen will prompt a countdown for you to wait, after it expires, turn the water pump back on after necessary changes have been made. After the change is complete, you can press DONE to continue and the water pump will turn back on.
6. Weld Current - This button allows the user to change the current anywhere between 1.00 kA and 14.00 kA. Keep in mind, the current output can be limited by the power installation in your building.
7. Electrode Force - This button allows the user to adjust the force applied at that tips of the weld gun. The units are daN also known as dekanewtons. This setting can be adjusted between 160 and 600 daN. Keep in mind, the force the welder is able to reach is based on the input supply pressure from your compressor. See Figures 8 and 9 for the necessary input supply pressure to your machine.
8. Weld Type - This button allows the user to change between 3 different weld types: Single, Dual, and Pulse.
Single: The welder attempts to provide the set weld current for a set amount of time.
Dual: The welder attempts to provide a set preheat current for a set amount of time and then a set weld current for a set amount of time. This may be used for coated steels or weld bonding applications. See section 5.5 below. **NOTE:** Pre-weld time and current should be lower than “weld” time and current.
Pulse: The welder attempts to provide the set weld current for a set amount of ON time with a set of amount of OFF time pauses in between for a set number of repetitions. See section 5.6 below.

9. Manual Weld Advanced Settings - This button allows the user to change Squeeze Time, Hold Time, Rise Time, and Fall Time. You will need the Administrator password in order to access this setting.
 Squeeze Time: The amount of time between when the weld trigger is pressed and held and when the weld current is provided.
 Hold Time: The amount of time between after the weld current stops and the electrode releases the workpiece.
 Rise Time: The amount of time it takes for the welder to reach full current.
 Fall Time: The amount of time it takes for the welder to fall down from full current to 0.

10. Manual Mode Help - This button shows the user help information that applies to the Manual Mode Weld screen.

i4s Input Pressure (psi) Required For Output Force

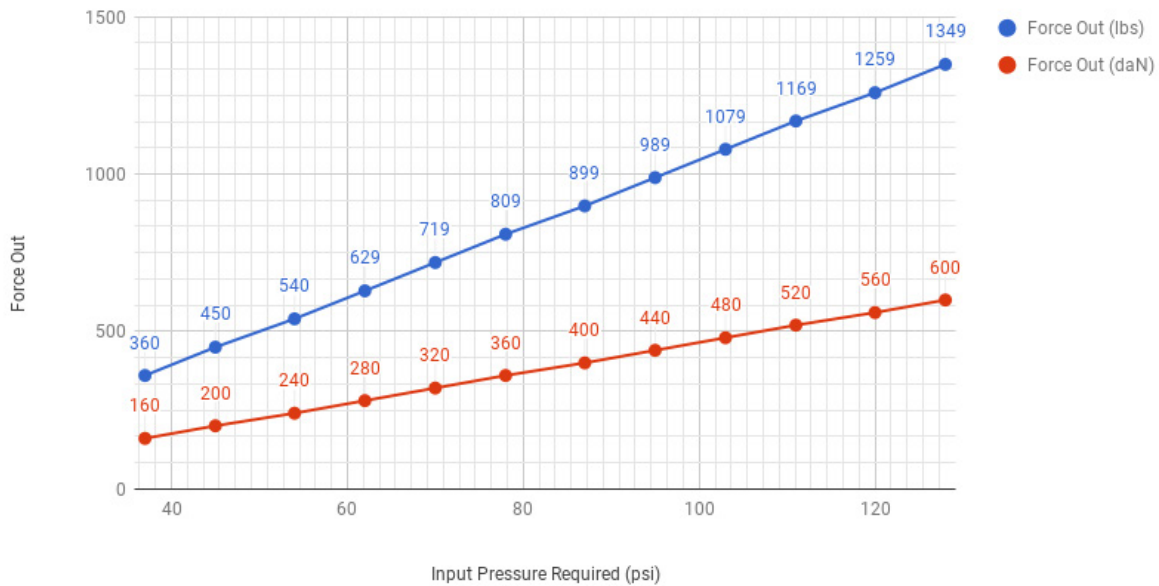

Figure 5.5

i4s Input Pressure (bar) Required For Output Force

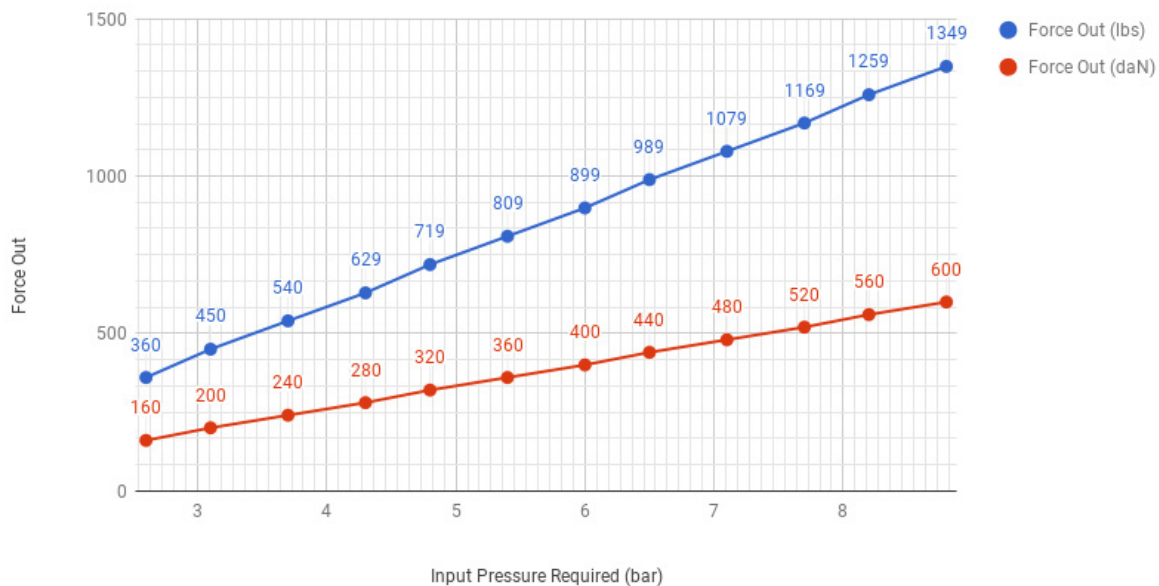

Figure 5.6

8.1 Double Sided Welding Manual Mode

Manual Mode is for users that want complete control over their weld settings. Manual Mode comes with pre-loaded common weld programs that can be over written by the user and can be reset in the global settings if necessary (Figure 5.7). **IMPORTANT:** verify proper weld setting by performing regular destructive test.

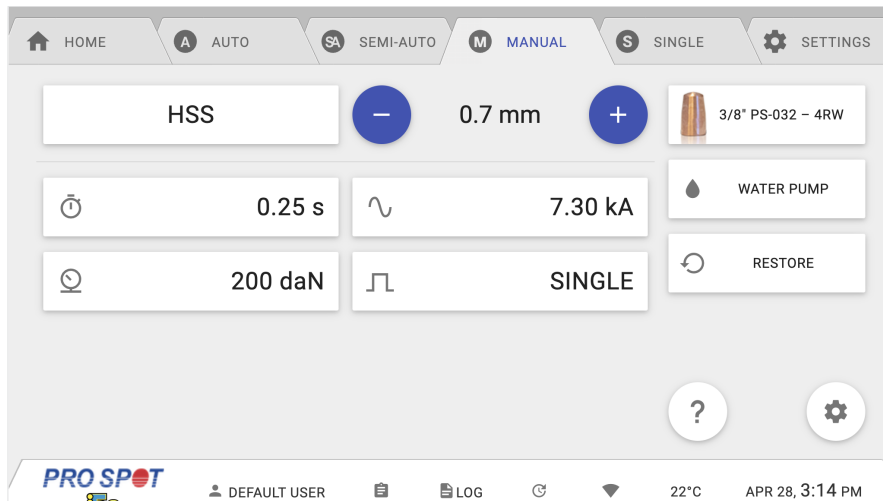

Figure 5.7

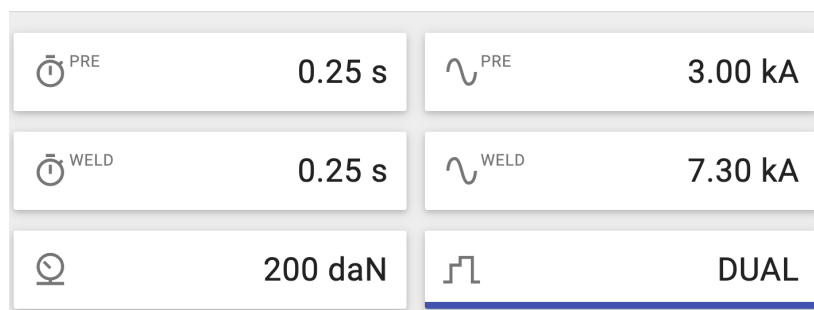

Figure 5.8

Available settings depend on which weld type is selected (Figure 5.8).

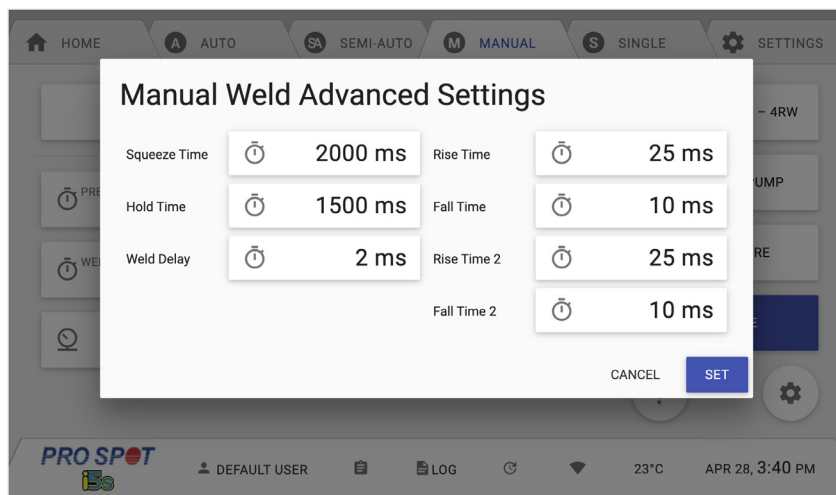

Figure 5.9

To change Advanced Settings touch the Settings Button in the lower right-hand side of the screen. A Manual Weld Advanced Settings Menu will pop with more settings (Figure 5.9). **NOTE:** These settings should only be changed after consulting Pro Spot Technical support.

8.2 Manual Mode Welding: Dual Weld Settings

When you change the Weld Type from Single to Dual, there are additional parameters available to adjust the weld as shown below.

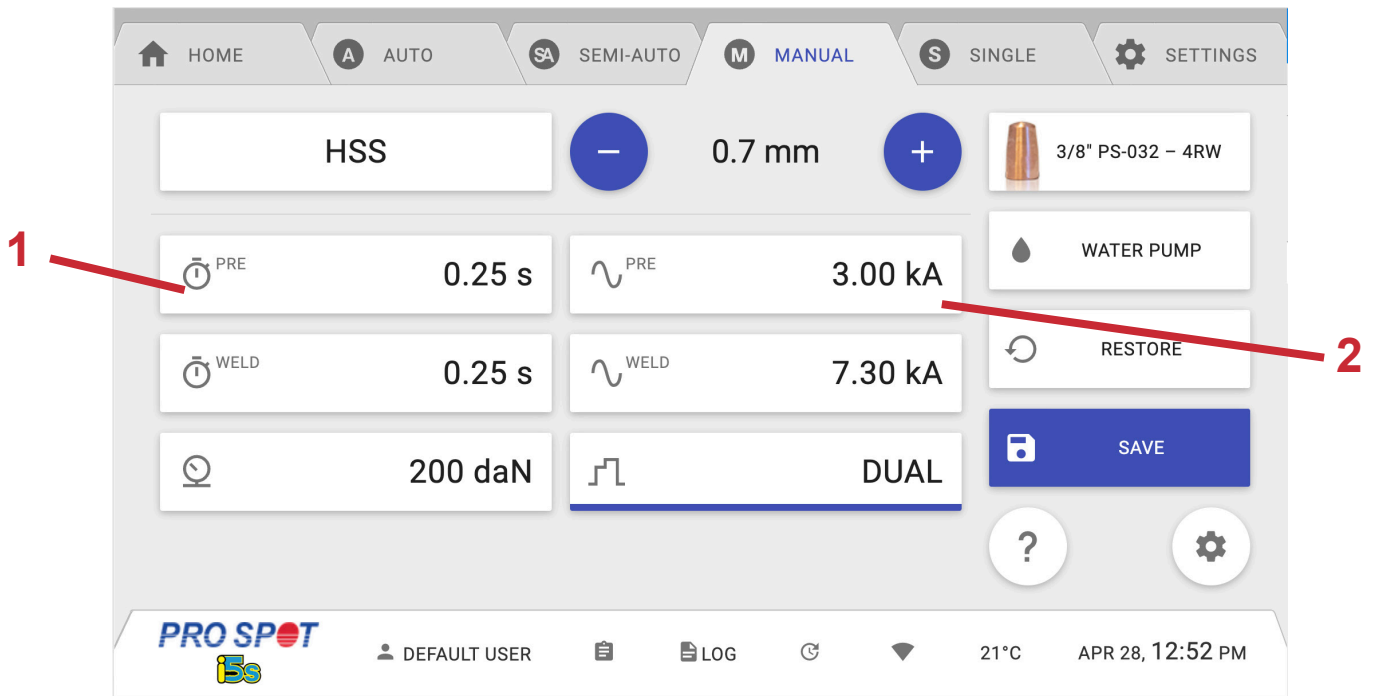

Figure 5.10

1. Preheat Time - This button allows the user to adjust the amount of time the welder applies the Preheat Current.
2. Preheat Current - This button allows the user to adjust the Preheat Current which is applied before the Weld Current in a Dual Weld. This precurrent is used to burn any non-conductive material away before applying the full Weld Current.

Using the example above, below describes what the welder would do:

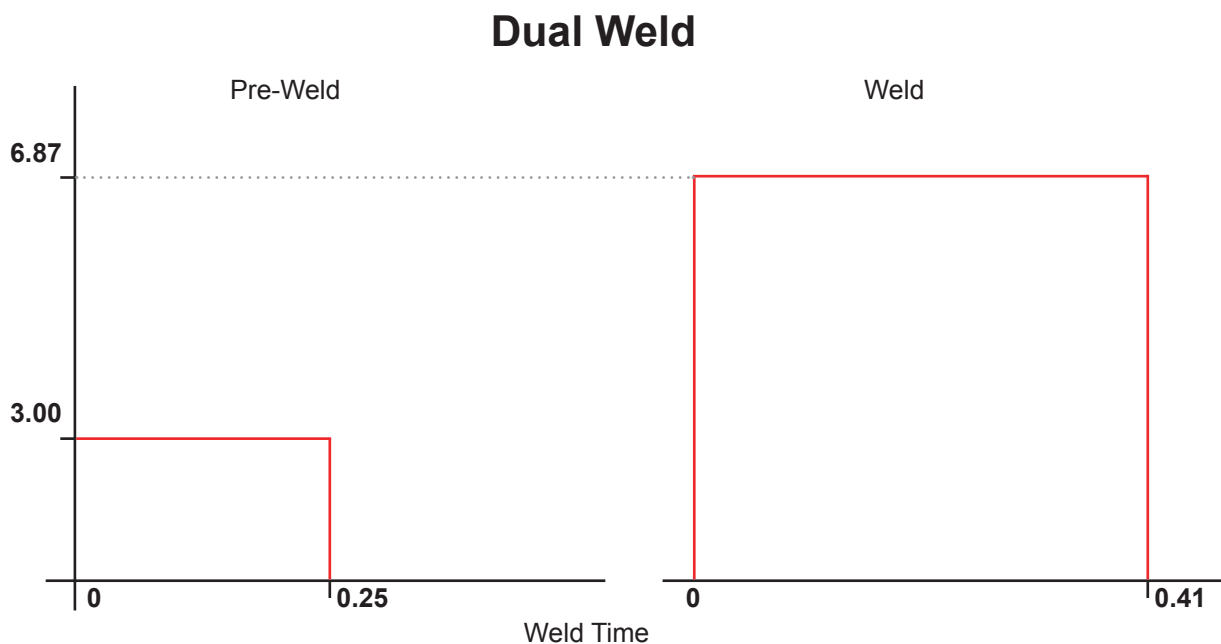

Figure 5.11

8.3 Manual Mode Welding: Pulse Weld Settings

When you change the Weld Type to Pulse, there are additional parameters available to adjust the weld as shown below.

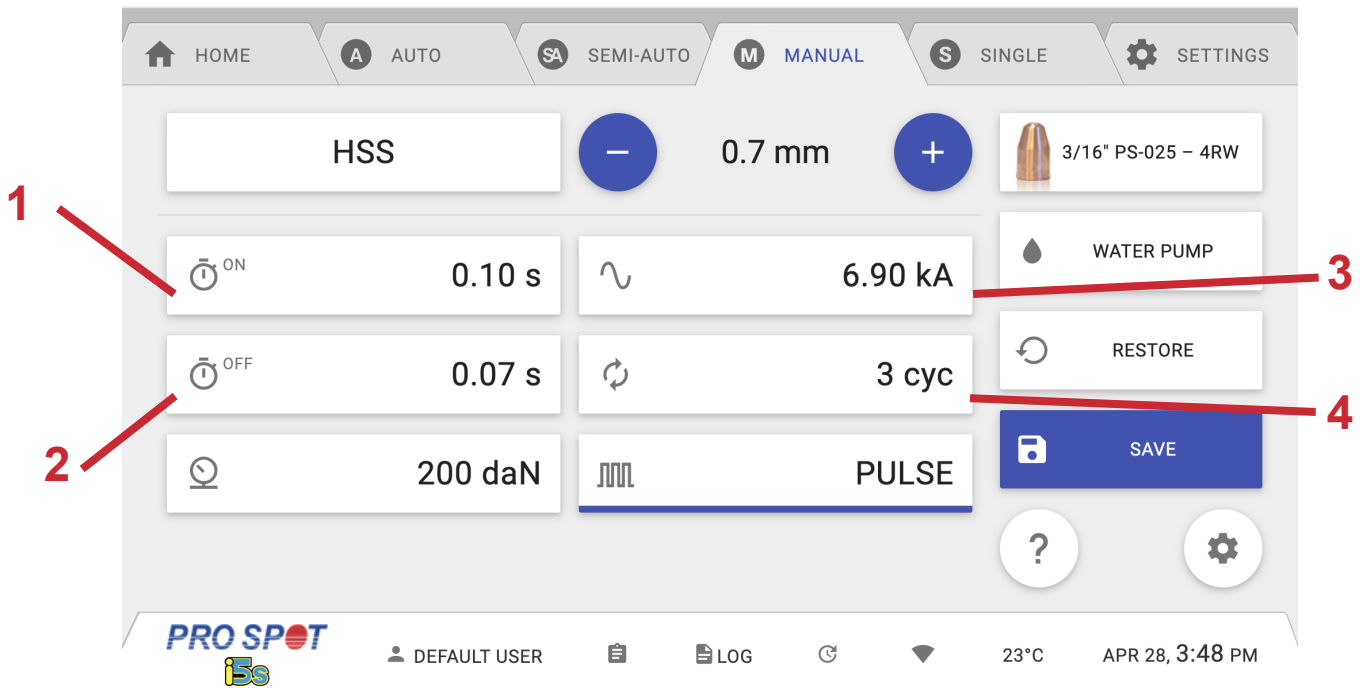

Figure 5.12

1. On Time - This button allows the user to adjust the amount of time the Weld Current is applied during each pulse repetition.
 2. Off Time - This button allows the user to adjust the amount of time the Weld Current is off between each pulse repetition.
 3. Weld Current - the amount of weld current produced during each weld repetition.
 4. Pulse Count - This button allows the user to adjust the number of repetitions in the weld cycle.
- Using the example above, below describes what the welder would do:

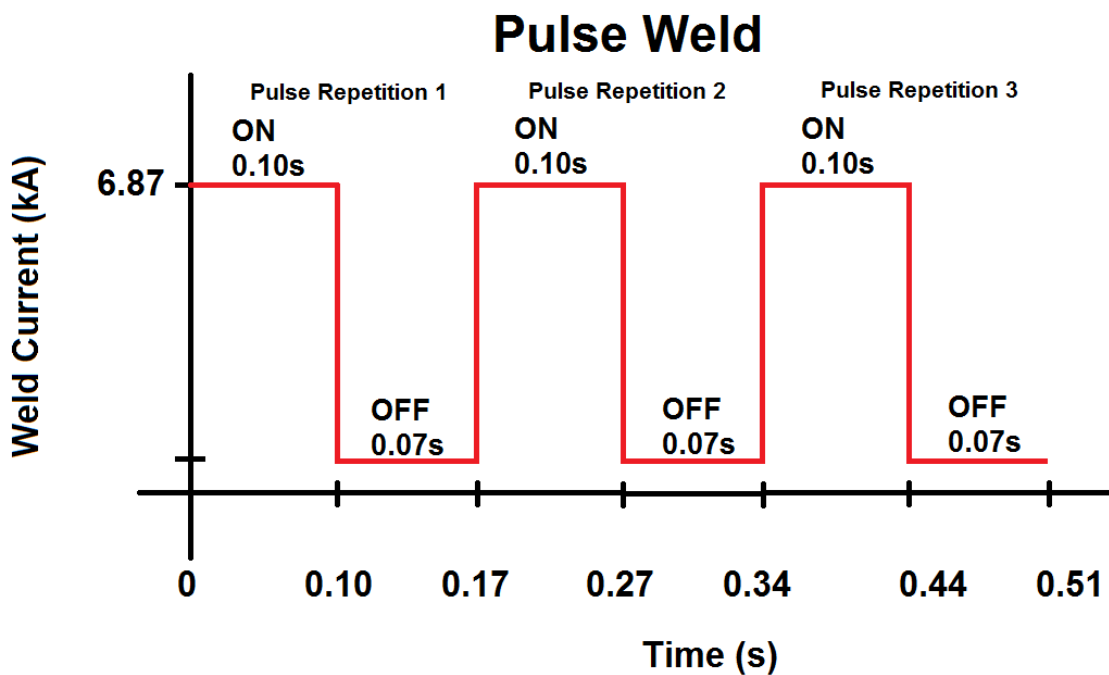

Figure 5.13

8.4 Creating a Custom Weld

How To Create A Custom Weld:

1. From the Weld Material screen, select Custom. Weld Material button gives several different options for pre-sets including an option called Custom which is used to store user presets. Start by selecting Custom for Weld Material.

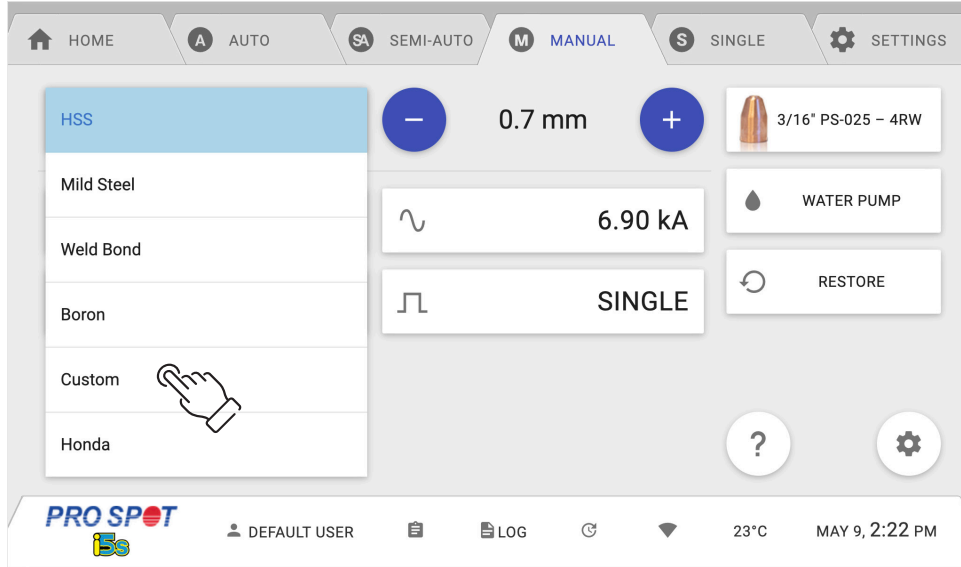

Figure 5.14

2. Select the appropriate weld cap by pressing the Weld Cap Button (Figure 5.15).

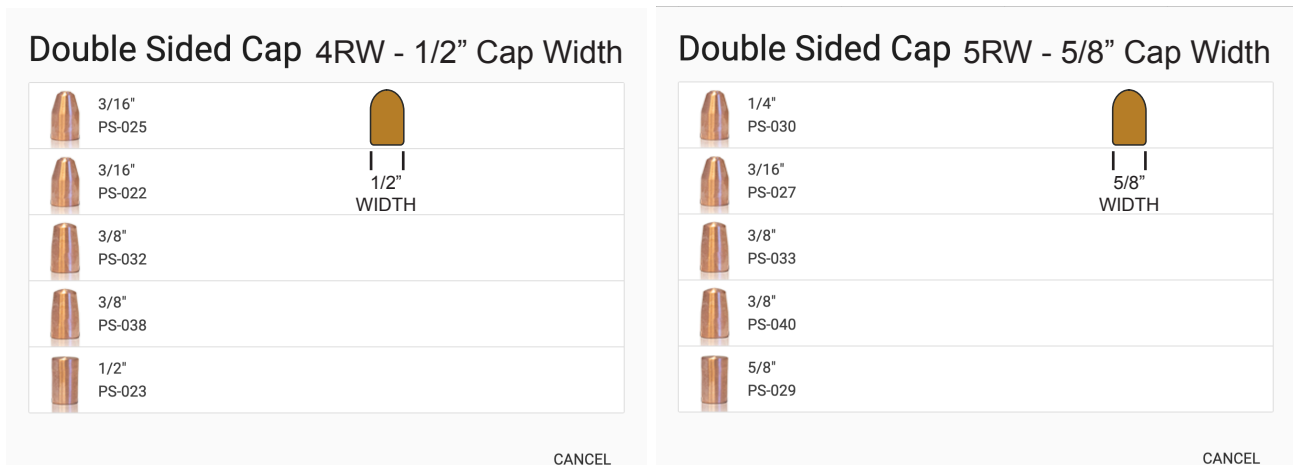

Figure 5.17

3. Select one of the 3 weld types in the Main Manual Mode Screen:

- Single Weld: A single weld.
- Dual Weld: Two consecutive current pulses.
- Pulse Weld: 3-9 consecutive current pulses.

Save new selection to overwrite the current program (Figure 5.17).

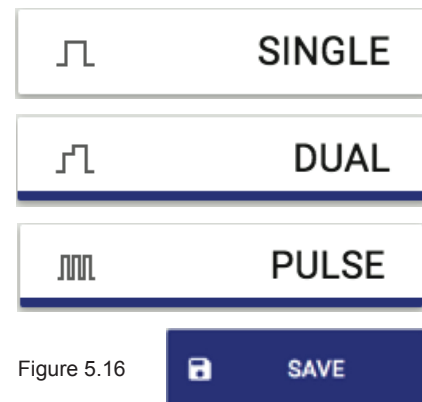

Figure 5.16

4. Choose The Settings.

Set the desired parameters by selecting each one to be edited and modified using the open keypad.

If you selected Single Weld, you will see the following options:



How much current is applied during the weld.



Amount of time current is applied during the weld.



How much pressure is applied during the weld.

If you selected Dual Weld, you will see the following options:



Amount of time applied to the first pulse



How much current is applied to the first pulse



How much pressure is applied to the weld.



Amount of time applied to the second pulse.



How much current is applied to the second pulse.

If you selected Pulse Weld, you will see the following options:



Amount of time each pulse is applied.



How much current is applied during each pulse during the weld.



How much pressure is applied to the weld.



Amount of time between each pulse.



Number of pulses that are applied (between 3 and 9).

9.0 Two-Sided Welding (Semi-Auto Mode)

Semi-Auto Mode gives the user a high level of customizability that is based on the materials being welded rather than specific time and current settings. The user can select either a predetermined weld setting (out of 16 common metal/coating/surface condition combinations) or create a custom stack between 2-5 pieces of metal with industry standard coatings, surface conditions and material thicknesses.

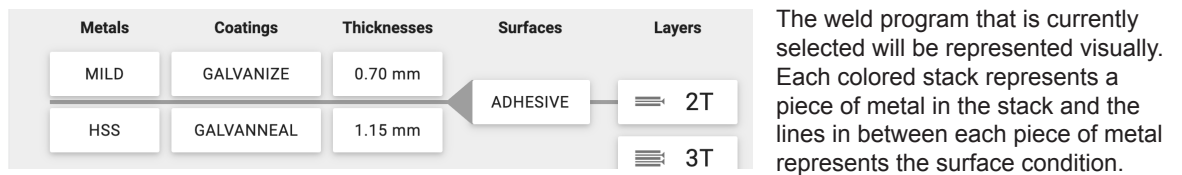
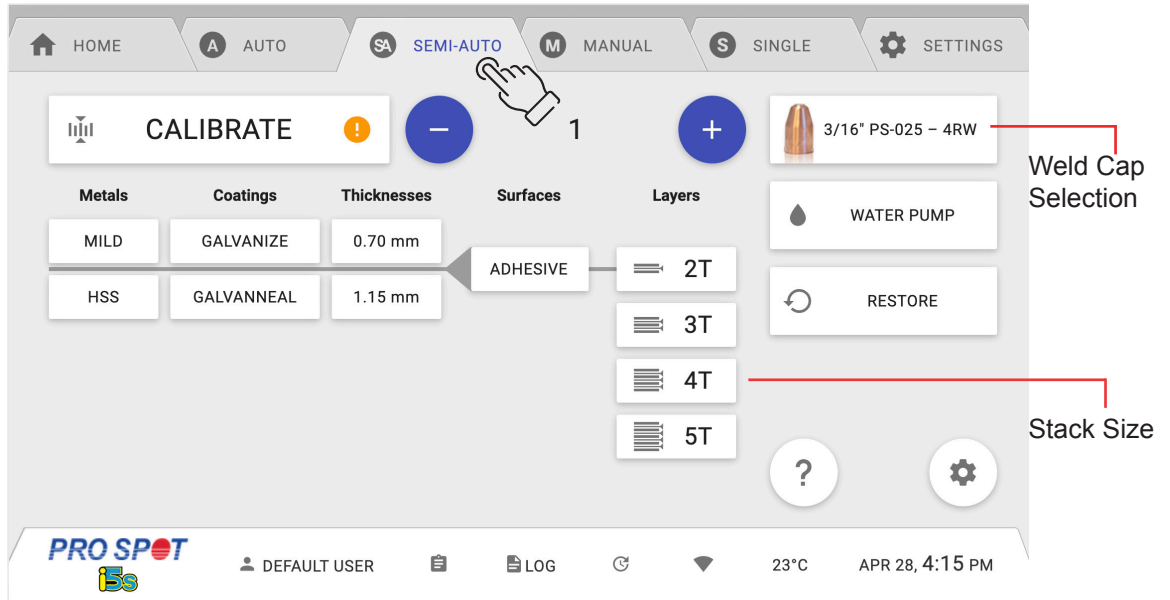

1. Select a Weld Cap, Stack Size, and Program

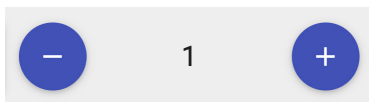

Use the plus and minus buttons to navigate through the different weld programs.

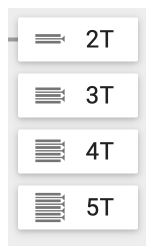

To create a custom weld program in Semi-Auto Mode, first select the size of stack you are working with.

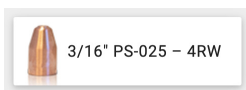

Press the weld cap selection button on the main Manual Mode screen, then select appropriate weld cap.

2. Edit Mode

Select a metal and coating for each layer

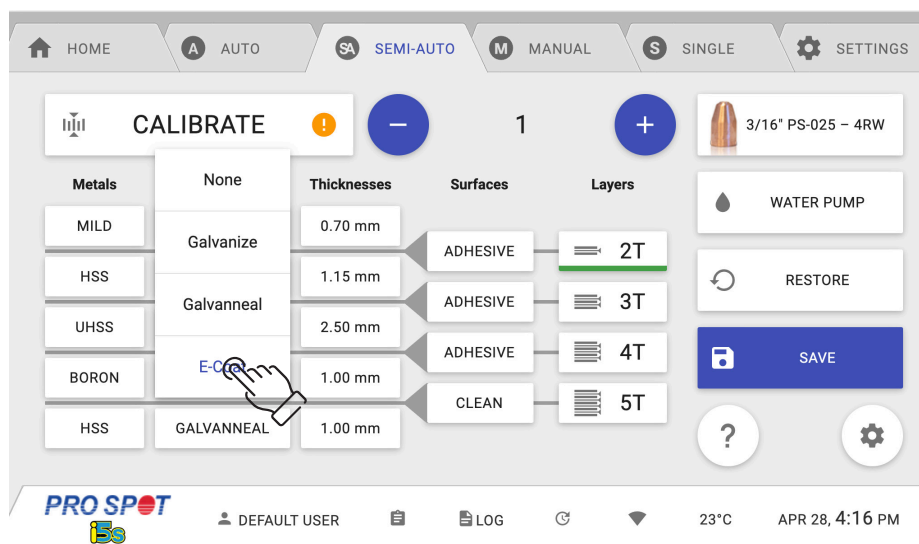
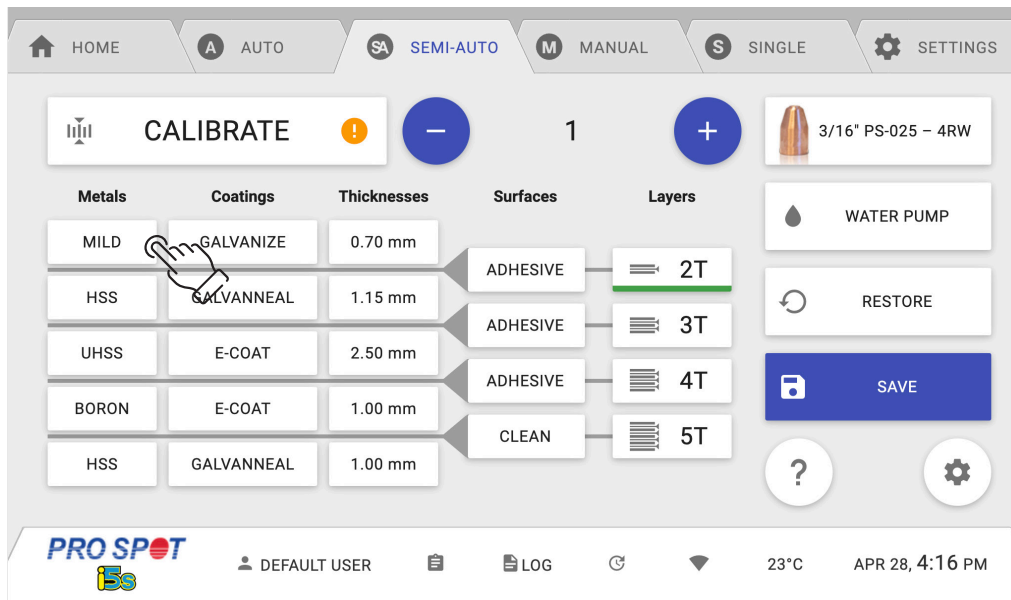

Press the thickness field, this will bring up a key pad. Enter the thickness of the material and press the green check mark.



Press the surface condition button to cycle through several different surface scenarios.

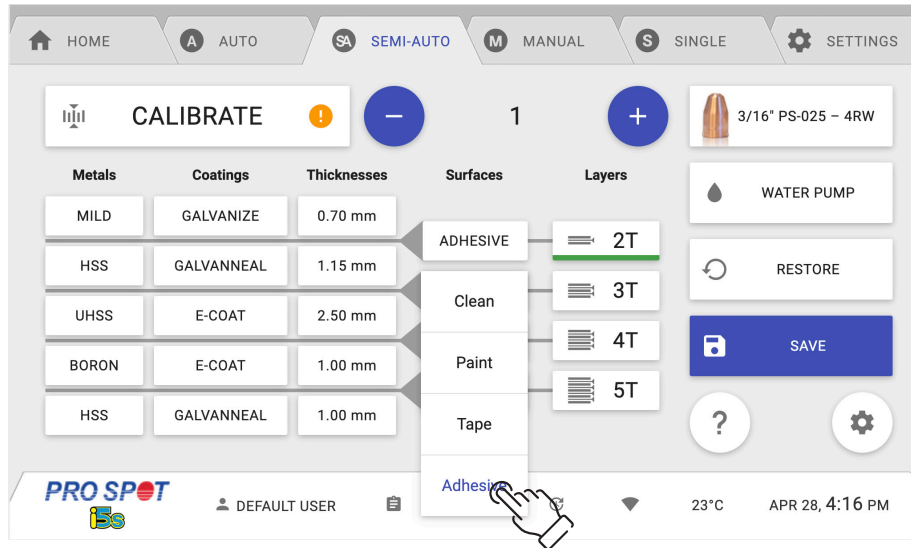

Press the Save button to save changes.

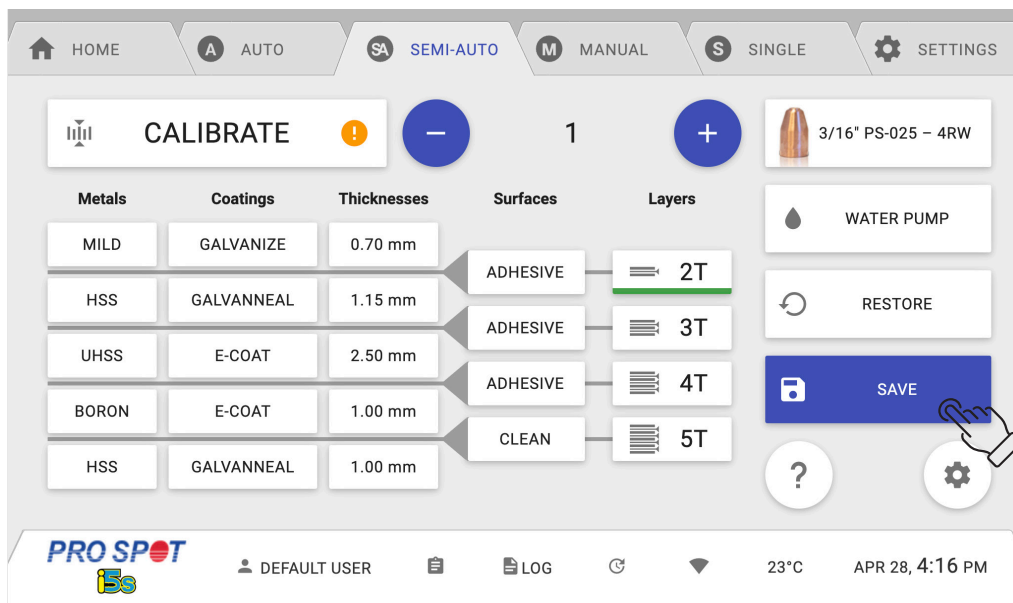

10.0 Welding Electrode Maintenance



IMPORTANT! Using incorrect welding electrodes with extension arms may result in weak welds and/or damage to your welder.
IMPORTANT! En utilisant des électrodes de soudage inexactes au bras d'extension peut donner des soudures faibles et / ou endommager votre soudeur.

10.1 Electrode Components

PSW-080 SHANK/CAP COMPONENTS

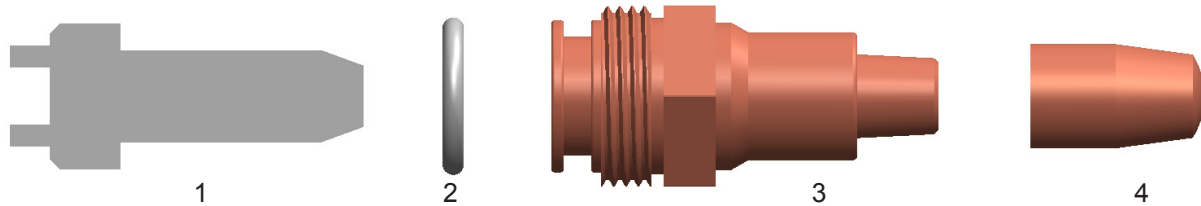

1. Divider - P/N 90-1711
2. O-ring - P/N 52-0086
3. Screw-In Shank - P/N 90-1710
4. Weld Cap - P/N PS-0032

PSW-520 SHANK/CAP COMPONENTS

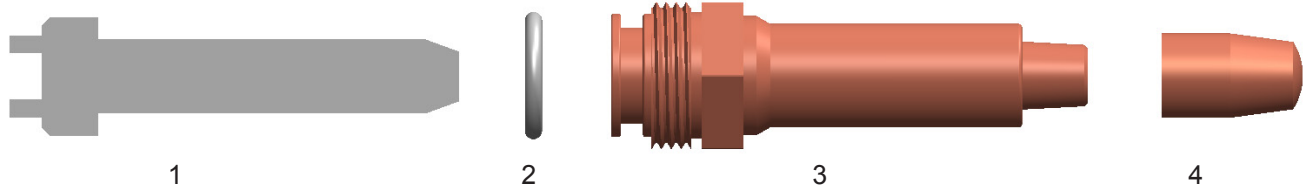

1. Divider - P/N 90-1726
2. O-ring - P/N 52-0086
3. Screw-In Shank - P/N 90-1717
4. Weld Cap - P/N PS-0032

PSW-WH-090 SHANK/CAP COMPONENTS

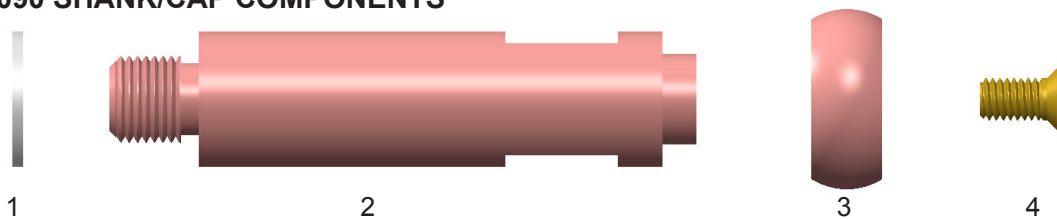

1. Washer - P/N 52-9029
2. Screw-In Shank - P/N 90-0416
3. Weld Washer - PS-1135
4. Cap Screw - P/N s-617

10.2 Welding Electrode Maintenance

In order to maintain structurally-sound welds, it is important to keep your welding electrodes and weld caps from forming any build-up. It is also important to maintain the proper diameter. Clean electrodes with a file or Tip Sharpener (Electrode Dresser) and periodically replace weld caps.



CLEAN TIPS



DIRTY TIPS



WARNING! The electrodes may be hot. Use caution when handling them.

ATTENTION! Les électrodes peuvent être chauds. Soyez prudent lors de leur manipulation.

Tip Sharpener











Watch Video

Cap cleaning:

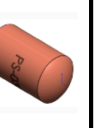
1. Turn off the i5s.
2. Connect the Tip Sharpener to a compressed air hose.
3. Set the sharpening blade on the weld cap to be cleaned.
4. Hold down the paddle switch while applying a slight pressure against the weld cap for about 10-15 seconds.
5. Repeat these steps 3 and 4 until all debris is cleared from the weld cap and there is a clear connection path between both tips.

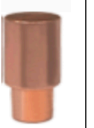
NOTE: use inline valve to lower air pressure to the Tip Sharpener. Tip sharpener should not be used at full speed.

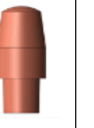
10.3 WELD CAP AND TIP DRESSER IDENTIFICATION TABLES

4RW Weld Caps										
Cap Image					Coming soon					
Cap No.	PS-024 Male	PS-025 Female	Male	PS-038 Female		PS-022 Female	PS-035 Male	PS-023 Female	PS-036 Male	PS-032 Female
Shape	A-Cap		Honda Cap			B-Cap	F-Cap		.375 Radius	
Dresser	PLT-50/A		PLT-44/A			PLT-48/A	PLT-49/A		PLT-46/A	
Blade	PLT-29		50-9038			50-9032	50-9031		50-9025	
Chuck	PLT-02		PLT-02			PLT-02	PLT-02		PLT-02	
Ring	PLT-03		PLT-03			PLT-03	PLT-03		PLT-03	
Nut	PLT-01		PLT-01			PLT-01	PLT-01		PLT-01	

5RW Weld Caps										
Cap Image					Coming soon				Coming soon	
Cap No.	PS-031 Male	PS-030 Female	PS-041 Male	PS-040 Female		PS-027 Female		PS-029 Female		PS-033 Female
Shape	A-Cap		Honda			B-Cap	F-Cap		.375 Radius	
Dresser	PLT-52/A		PLT-43/A			PLT-51/A	PLT-45/A		PLT-47/A	
Blade	50-9030		50-9040			50-9027	50-9033		50-9026	
Chuck	PLT-02		PLT-02			PLT-02	PLT-02		PLT-02	
Ring	PLT-04		PLT-04			PLT-04	PLT-04		PLT-04	
Nut	PLT-01		PLT-01			PLT-01	PLT-01		PLT-01	

10.4 i5s Shank and Cap Removal

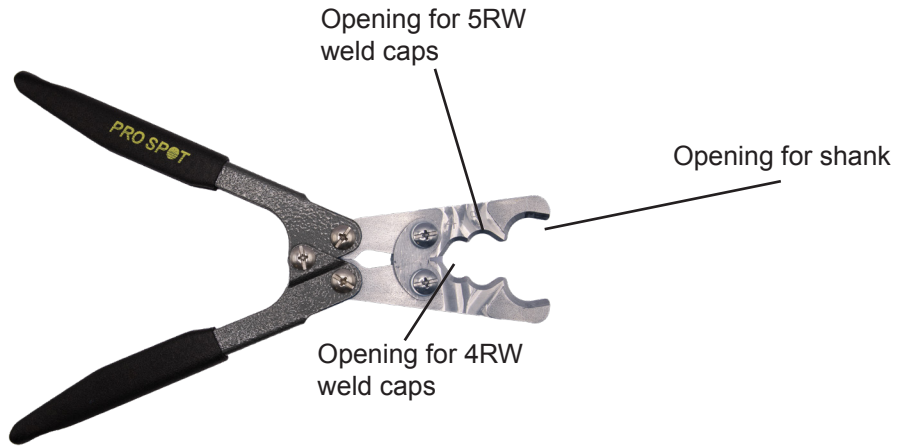

Each i5s Spot Welder will be shipped with a plier. It is used for cap and shank removal.

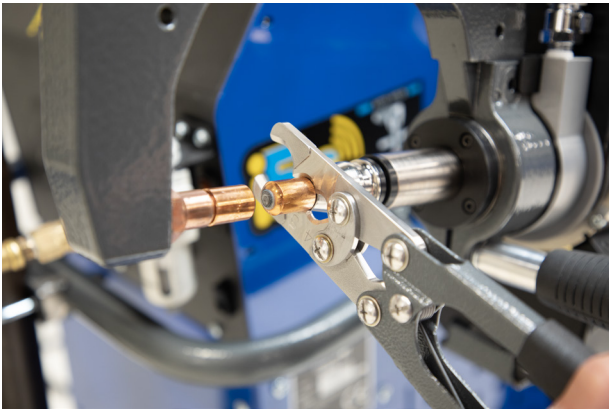

Weld Cap Removal

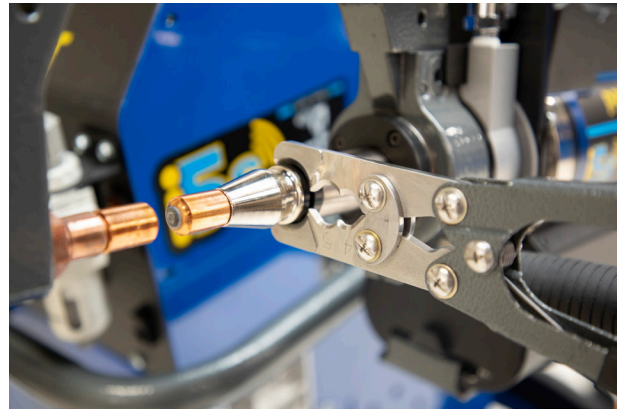

Shank Removal



Pro Spot International, Inc.
5932 Sea Otter Place
Carlsbad, CA 92010

Toll Free (US Only): (877) PRO SPOT
Phone: (760) 407-1414
Fax: (760) 407-1421

E-mail: info@prospot.com
Web: www.prospot.com