

Resistance Spot Welder

Instruction Manual

MNL-i4s-v1.6





Pro Spot International specializes in quality welding and repair products for the collision repair industry. Pro Spot owns three patents for special welding equipment and applications, and works with the largest auto manufacturers in the world. Pro Spot is a proud 'MADE IN THE USA' manufacturer in Carlsbad, CA. The turnkey facility includes Design, Engineering, Machine and Sheet Metal Shops, Powder Coating, Assembly, Training and Customer Support. The Pro Spot equipment line includes resistance spot welders, aluminum & steel dent repair systems, pulse MIG welders, rivet guns and tools, dust-free sanding systems, fume extraction and more.

Pro Spot provides on-going training to all of our distributors and their technicians, therefore, all owners of Pro Spot products receive complete training first hand. Pro Spot has two ASE certified training programs that are I-CAR alliance approved. Pro Spot has a fully equipped training facility at their Headquarters in Carlsbad, CA for groups to come in and train on all products. To stay up-to-date, Pro Spot offers their unique *my.prospot.com* which includes interactive training courses for shops and technicians to access online.

Pro Spot is constantly striving to improve. Whether that means designing innovative equipment, implementing cutting edge technical support or further improving their already extensive training programs, Pro Spot is always looking for ways to better our customer's experience.



PRO SPOT
QUALITY WELDING SYSTEMS

Pro Spot International, Inc.
5932 Sea Otter Place
Carlsbad, CA 92010

Toll Free: (877) PRO SPOT
Phone: +1 (760) 407-1414
Fax: (760) 407-1421

E-mail: info@prospot.com
Web: www.prospot.com



Technical Support

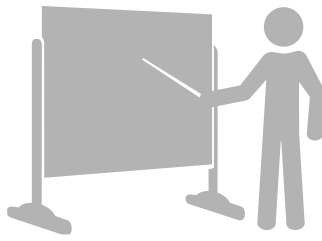

Training

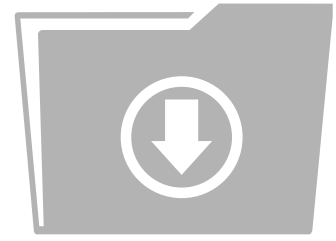

Documents

Pro Spot wants to personalize your experience.

Come to my.prospot.com and register today! Gain access to exclusive product demonstration videos, training, important product documents, and more. *My.prospot.com* is a site just for you with an easy to use interface that is custom tailored based on the products you own. This means quicker troubleshooting solutions, with less hassle. My Pro Spot is constantly evolving and we have more exciting features to come.

[My.prospot.com](http://my.prospot.com) is where you'll find updates on new i4s related products and features so be sure to check it out.

PRO SPOT
QUALITY WELDING SYSTEMS

Simulations Distributors Omar Olea

My Pro Spot

i4 Sim
Take a tour of the i4 resistance spot welder. Get to know the software and make sample welds.

Training
Our CASE certified and I-CAR approved training program offers training in both resistance spot welding and MIG welding. [Learn more >](#)

Tech Support
Documentation and troubleshooting guides. We plan to expand on this feature soon.

File Cabinet
All available files in one place. User manuals, spec sheets, marketing material and more.

i5 Sim
Simulation of the i5 software and gun.

News
Bulletin: Pro Spot Announces Art Ewing as Sales & Marketing Director - Canada - 327.3 KB
NACE
SEMA

Media
Tweets by @prospotwelding
[#prospot](#) [#welding](#) [#resistance](#) [#repair](#) [#autobody](#) [#bodyshop](#)

Embed [View on Twitter](#)

Table Of Contents

i4s Quick Start Instructions	1
1.0 Introduction	2
2.0 Safety	3
2.1 Important Warnings	4
2.2 Cooling System	5
3.0 Installation	6
3.1 Packaging & Delivery Inspection	6
3.2 Welder Assembly	6
3.4 Connecting The Electrical Supply	7
3.5 Connecting the Air Supply	7
4.0 Operation	8
4.1 Before You Begin Welding	8
4.2 About Your Welder	9
4.3 Turning On The i4s	10
4.4 How To Login	11
4.5 i4s Home Screen	12
4.6 i4s General Settings Menus	13
4.7 Administration Settings Menus	18
5.0 Double Sided Welding Programs	26
5.1 Double Sided Welding Menu Guide	27
5.2 Auto Mode Calibration	28
5.3 Double Sided Welding Manual Mode	29
5.4 Manual Mode Welding Menu Guide	30
5.5 Manual Mode Welding: Dual Weld Settings	32
5.6 Manual Mode Welding: Pulse Weld Settings	33
5.7 Creating A Custom Weld	34
6.0 Single-Sided Welding	36
6.1 Single-Sided Welding Menu Guide	37
7.0 i4s Weld Gun	38
7.1 i4s On Gun Screen & Gun Controls	39
7.2 Extension Arms	41
7.3 Electrode Components	42
8.0 Electrode Alignment, Removal & Maintenance	43
8.1 Removing Welding Electrodes	44
8.2 Welding Electrode Maintenance	45

i4s Quick Start Instructions



WARNING! Read this manual in its entirety before attempting to weld with the i4s. Before turning on the machine, make sure it is connected to the proper electricity by certified professionals. The water tank should be filled with a 50/50 water and antifreeze solution. Before filling, make sure to secure all water hoses.

1 Weld Gun Check

- (A) Verify that the hoses are secure in place.
- (B) Verify that the arm handle is tightened.

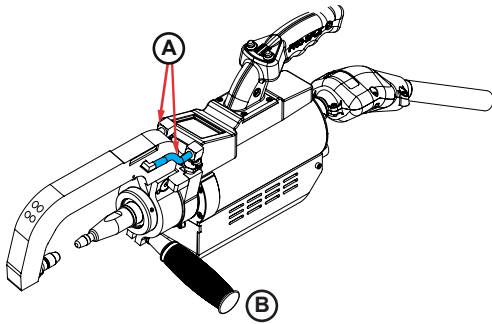

3 Login



- (A) Select User Login.
- (B) Enter the password and select the green check button.
Note: The default user password is 1234

2 System Checks and Power On

- (A) Verify the presence of air pressure.
Recommended minimum input pressure is 80 PSI.
See Section 4.2.1 for more information.



- (C) Verify all 3-phase lights are illuminated.

4 Navigation

- (A) The i4s touch screen is used to navigate through menus and select options.

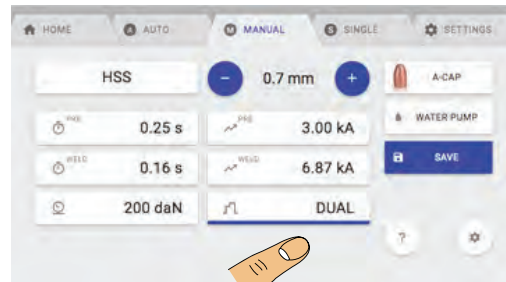

5 How To Calibrate The i4s Spot Welding Gun

CAUTION DO NOT PUT MATERIAL BETWEEN ELECTRODES DURING CALIBRATION



1. Press the calibrate button to enter calibration mode.
2. Press and hold the reverse button (top-left) on the gun.
3. Press and hold the weld trigger and the top right button on the gun to calibrate.

Note: • Recalibrate every 100 welds
• Every arm change
• Every time Auto Mode is entered.

6 Start Welding

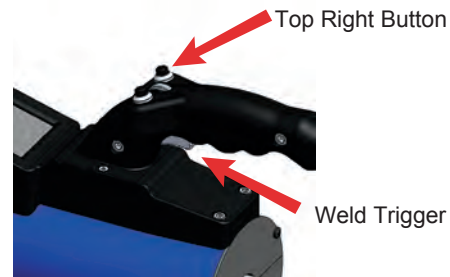

1. Place the stackup between the weld caps and be sure to use shunt clamps if this is the first weld.
2. Press and hold the weld trigger and top right button on the gun to weld.

1.0 Introduction

Congratulations on your new Pro Spot i4s Spot Welder!

With the i4s and its connected support system, you will experience a rapid increase in productivity. The integrated and user friendly features, paired with superior speed and overall weld quality will quickly make the i4s a vital element of your business.

Team Pro Spot looks forward to supporting you.

For videos on products, training and tips, visit our YouTube Channel: www.youtube.com/prospotinternational

To speak to a customer service representative visit www.prospot.com or e-mail us at info@prospot.com.

For parts or service contact your local distributor, or call Toll free: 1-877 PRO-SPOT (US only) or 1-760-407-1414

The following information will be needed when you call Pro Spot:

*MODEL TYPE: i4s

*SERIAL NO: _____ (The serial number is located on the left side of the unit)

The i4s Spot Welder is used by body shops for the purpose of duplicating weld procedures implemented by vehicle manufacturers.

Pro Spot International, Inc. will not be held responsible in any way for intentional or unintentional damage caused by incorrect use of this equipment or using the equipment for an unintended application.

Warranty

Pro Spot International, Inc. offers a limited two-year guarantee initiated on the date of delivery of the new welder. This guarantee covers material defects and assumes normal care and maintenance.

This guarantee assumes that:

- The equipment is correctly installed and inspected by a certified Pro Spot representative.
- The equipment has not been altered or rebuilt without approval from Pro Spot International, Inc.
- Genuine Pro Spot International, Inc. parts and consumables are used to make repairs.
- Preparation and maintenance has been carried out according to the instructions in this manual.

All claims on warranty must verify that the fault has occurred within the guarantee period, and that the unit has been used within its operating range as stated in the specifications. All claims must include the product type and serial number. This data is stamped on the name plate.

Note: This instruction manual provides advice as well as instructions for installation, operation, maintenance and troubleshooting.



IMPORTANT! Read this manual carefully to become familiar with the proper operation of the welder. Do not neglect to do this as improper handling may result in personal injury and damage to the equipment.



IMPORTANT! Lisez ce Mode d'Emploi attentivement afin de vous familiariser avec le bon fonctionnement du soudeur. Ne négligez pas de le faire puisque une mau-vaie manipulation peut conduire aux blessures et dommages à l'équipement.

This manual is to be used for illustrative purposes only. It does not necessarily include the design of the equipment available on the market at any given time. The equipment is intended for use in accordance with current trade practice and appropriate safety regulations. The equipment illustrated in the manual may be changed without prior notice.

The contents in this publication can be changed without-prior notice.

The information featured in this publication is protected by copyright laws. No part of this publication may be reproduced, stored in a system for information retrieval or be transmitted in any way without Pro Spot International, Inc.'s written consent.

Conformity with directives and standards: i4s complies with CE standards.

2.0 Safety

Safety & Environmental Specifications

The i4s Spot Welder is designed for indoor use - Protection Degree IP21S. The i4s Spot Welder is designed to operate from -10° C to 40° C. The unit may be stored and transported in an ambient temperature from -20° C to +55° C. The unit can be operated at 95% Relative Humidity (RH). Do not operate the unit on a slope of more than 10°.

General

The i4s Spot Welder has been designed and is tested to meet strict safety requirements. Please read the following instructions carefully before operating the i4s and refer to them as needed to ensure the continued safe operation of the welder.

Information provided in this manual describes the suggested best working practices and should in no way take precedence over individual responsibilities or local regulations.

The i4s Spot Welder is designed to comply with all applicable safety regulations for this type of equipment. During operation, it is the responsibility of each individual user to consider:

- The personal safety of themselves and others.
- The safety of the welder through the proper use of the equipment and in accordance with the descriptions and instructions provided in this manual.

By observing and following the safety precautions, users of the i4s Spot welder warrant safer working conditions for themselves and others.

2.1 Warnings & Important Notices

The following types of safety signs are used on the equipment and in Pro Spot's instruction manuals:



Caution.
Read instruction manual.



Attention!
Lire Mode d'Emploi.



Prohibited.
Prohibits behavior that can cause injury.



Interdit.
Interdit aux comportements qui peuvent provoquer des blessures.



Command.
Calls for a specific action.



Commande.
Appelle à une action spécifique.



Warning.
Notice of personal injury risk and or damage to equipment.



Avertissement.
Avis de risque de blessure personnelle et / ou d'endommager l'équipement.



Warning.
Some parts of the welder may become hot after prolonged use.



Avertissement.
Certaines parties du soudeur peuvent devenir chaudes après une utilisation prolongée.



WARNING! Do not operate or place the welder near water, in wet locations or outdoors. Risk for injuries or damage to the welder.



WARNING! Do not place the welder on unstable or uneven ground. The welder might tip causing personal injuries or serious damage to the welder.



WARNING! Risk of electrical shock. All electrical connections must be made by a qualified electrician.



WARNING! Loose cables and hoses present tripping risks and possible injuries.



WARNING! Always use welding goggles when spot welding. Sparks are capable of causing injury to the eyes.



WARNING! Sparks from welding could start a fire, causing injury and property damage.



WARNING! Risk of damage to materials close to the welder, e.g to glass or textiles.



WARNING! For proper cooling efficiency, never operate the welder without connecting it to the compressed air source.



WARNING! All service and maintenance must be carried out by Pro Spot service personnel and service support.



WARNING! Risk for electrical shock. Unplug the welder from its electrical outlet before servicing, cleaning or maintenance of any kind.



IMPORTANT! The i4s welder may only be used by qualified personnel. Individuals using the welder must be educated in spot welding, collision repair and proper usage of the unit.



IMPORTANT! Do not turn off the welder while cooling is activated!



IMPORTANT! The air must be clean and free from oil and moisture. Use filter.



WARNING! Do not place any body parts between the electrode tips. Doing so will cause serious injury.



WARNING! When holding the gun, only hold it by the plastic handle on top and the rubber handle on the arm.



ATTENTION! Ne pas faire fonctionner le soudeur près de l'eau, en voie humide, ou à l'extérieur. Risque de blessures ou de dommages au soudeur.



ATTENTION! Ne placez pas le soudeur sur un sol instable ou irrégulière. Le soudeur peut basculer causant des lésions corporelles ou des dommages graves au soudeur.



ATTENTION! Toutes les connexions électriques doivent être faites par un électricien qualifié. Risque de choc électrique.



ATTENTION! Câbles et tuyaux lâches présentent des risques de déclenchement. Risque de blessures



ATTENTION! sur place. Les étincelles pourraient autrement blesser les yeux.



ATTENTION! Étincelles de soudure pourrait provoquer une incendie. Risque de blessures.



ATTENTION! Risque de dommages aux matériaux à proximité de la soudure, par exemple verre ou textiles.



ATTENTION! Pour refroidissement efficace, ne jamais soudeur sans attacher à la source d'air comprimé.



ATTENTION! Tout le service et l'entretien doivent être effectués par personnel et soutien de service Pro Spot. Risque de choc électrique.



ATTENTION! Débranchez le soudeur de la prise murale avant l'entretien, ou nettoyage. Risque de choc électrique.



IMPORTANT! Le soudeur i4s peut seulement être utilisé par personnel qualifié. L'utilisateur du soudeur doit avoir une connaissance de soudage par points et l'alignement des véhicules endommagés par collisions.



IMPORTANT! N'éteignez pas le soudeur pendant que le refroidissement est activé!



IMPORTANT! L'air doit être propre et sans huile et humidité. Utilisez un filtre



IMPORTANT! Ne placez aucune partie du corps entre les pointes d'électrode. Cela le fera causer des blessures graves.



IMPORTANT! Lorsque vous tenez le pistolet, tenez seulement par la poignée en plastique sur le dessus et le caoutchouc gérer sur le bras.

2.2 Cooling System

IMPORTANT! To ease transportation, the i4s welder is DELIVERED WITHOUT COOLANT. Be sure to fill coolant tank before turning on the welder. The cooling system turns on and off automatically. It starts at the first weld and shuts off three minutes after the last weld is completed. Make sure the water lines are connected properly.

The coolant tank is located in the rear of the unit, inside the center column. It should be filled with a 50/50 water & antifreeze solution. Maintain a level of at least 1.5 Gal (6L) of 50/50 solution at all times and do not overfill. When filling coolant it is recommended that a funnel be used to prevent unnecessary spills. When handling antifreeze or 50/50 solution, avoid contact with skin, eyes, or mouth. See antifreeze directions for proper handling instructions.



The i4s is equipped with a closed loop cooling system, 2.5 Gal (10L) tank, radiator with high powered fan cooling all the way to the tip of the electrodes.



The Coolant Level Indicator (located on the back, lower left hand side of the unit), should be checked regularly to maintain 1.5 Gal (6L) minimum in the tank.



Make sure the water cooling hoses are securely clipped into place before welding. Water will leak if the water feed and return hoses are not properly connected (see cooling hose connections).

Always make sure the welding arm is installed correctly, and the arm handle is firmly secured.



IMPORTANT! Make sure the water cooling hoses are securely clipped into place before welding.

IMPORTANT! Turn off the power to the water pump before disconnecting water hoses from the weld gun.

IMPORTANT! The i4s welder comes without coolant to ease transportation, be sure to fill coolant tank before turning on the welder.

IMPORTANT! If the thermal breaker has switched off the welder, please contact Pro Spot's authorized service personnel.

IMPORTANT! N'éteignez pas le soudeur pendant que le système de refroidissement est activé!

IMPORTANT! Si le disjoncteur thermique a éteint le soudeur, s'il vous plaît contactez personnel de service autorisé Pro Spot.

3.0 Installation

General

The i4s Spot Welder is inspected and tested prior to leaving the factory to guarantee consistent quality and the highest possible reliability. Follow the installation tips and operating instructions below to ensure user safety and proper welder performance.

WARNING! Do not operate or place the welder near water, in wet locations or outdoors. Risk for injuries or damage to the welder.



WARNING! Do not place the welder on unstable or uneven ground. The welder might fall causing personal injuries and damage to the welder. Do not operate on a slope of more than 10 degrees.

WARNING! When moving the welder, always check to make sure the wheel-locks are disengaged. Move the welder by grabbing the wraparound handle. Lock wheels in place prior to welding.

IMPORTANT! It is the responsibility of the owner to ensure that the equipment has been installed and inspected in accordance with applicable regulations, and all users are trained on safety and usage before it is put into service.

ATTENTION! Ne pas faire fonctionner le soudeur près de l'eau, en voie humide ou à l'extérieur. Risque de



ATTENTION! Ne placez pas le soudeur sur un sol instable ou irrégulière. Le soudeur peut tomber causant

ATTENTION! Lorsque vous déplacez la soudeuse, vérifiez toujours que les verrous de roue sont désengagés des dommages graves au soudeur. Ne pas utiliser sur une pente de plus de 10°

IMPORTANT! C'est la responsabilité du propriétaire de s'assurer que l'équipement a été installé conformément dans les instructions fournies. C'est aussi la responsabilité du propriétaire de s'assurer que le soudeur est inspecté conformément à la réglementation applicable avant qu'il ne soit mis en service. Ne pas utiliser pour dégelé les conduites d'eau congelées (17.1) blessures ou de dommages au soudeur. et que vous les déplacez en saisissant la poignée enveloppante.

3.1 Packaging & Delivery Inspection

Check the contents of the shipping container against the packing list, consignment note, or other delivery documentation to verify that everything is included and in the correct quantity. Check the i4s Spot Welder carefully to make sure that no damage has occurred during transport. If anything is damaged or missing, the welder may be unsafe to use until the part is repaired or replaced. If anything is missing, please contact your supplier. Remove all packaging material from the welder as items may be wrapped in packing materials. .

3.2 Welder Assembly

For your convenience, the i4s welder ships fully assembled, with the exception of the support arm (boom).

Due to differences in wiring codes and connection methods, no electrical plug comes with the welder. Consult a certified electrician for proper installation of the electrical plug.

Insert the support arm (boom) as shown in Figure 3.1

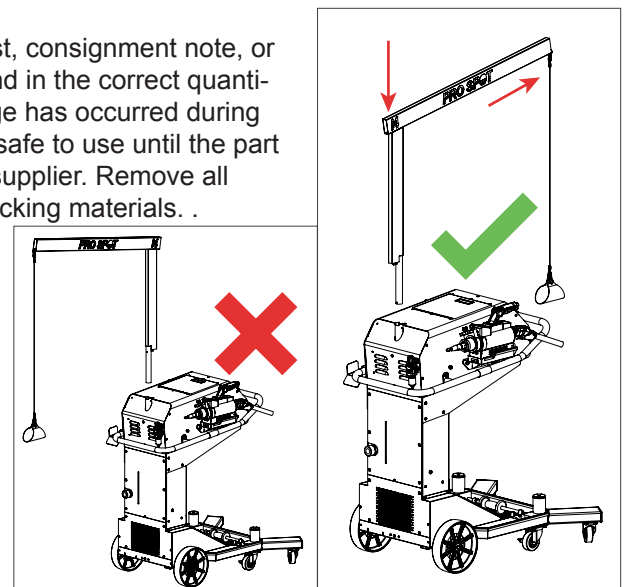

Figure 3.1

3.3 Connecting The Electrical Supply

The i4s Spot Welder is purchased based on voltage supply available at the shop. The i4s can be purchased in the following voltage / frequency combinations:

208-240V 50/60 Hz	U.S.A., Canada, Japan
400-420V 50/60 Hz	Europe, Australia
460-480V 50/60 Hz	U.S.A., Canada

WARNING: Plugging a machine into the wrong voltage can damage the machine.

Note: Make sure that the facility supply voltage and frequency are the same as shown on the welder name plate.

The power supply must have a ground connection. The supply must also be protected as follows:

The 208-240V 3-Phase requires a 60A breaker.

The 400-420V 3-Phase supply requires a 32A slow blow fuse (circuit breaker 32D).

The 460-480V 3-Phase supply requires a 32A slow blow fuse (circuit breaker 32D).



WARNING! All electrical connections must be made by a qualified electrician. Risk for electrical shock.

ATTENTION! Toutes les connexions électriques doivent être faites par un électricien qualifié. Risque de choc électrique.

1. Connect the green wire to ground.

Note: Make sure that the supply cable is at least 4 AWG at 208V and 400V. The i4s is rated for over voltage category III and pollution degree 3. (Contact Pro Spot or speak with your local rep on power requirements.)

2. If an extension cord is used with the welder, ensure that the length of the extension cord does not exceed 10m (30ft) and it meets the specifications of item 1 above. The cord must also be grounded. Consult an electrician for safe and proper installation of the electrical plug.

3.4 Connecting the Pneumatic Air Supply

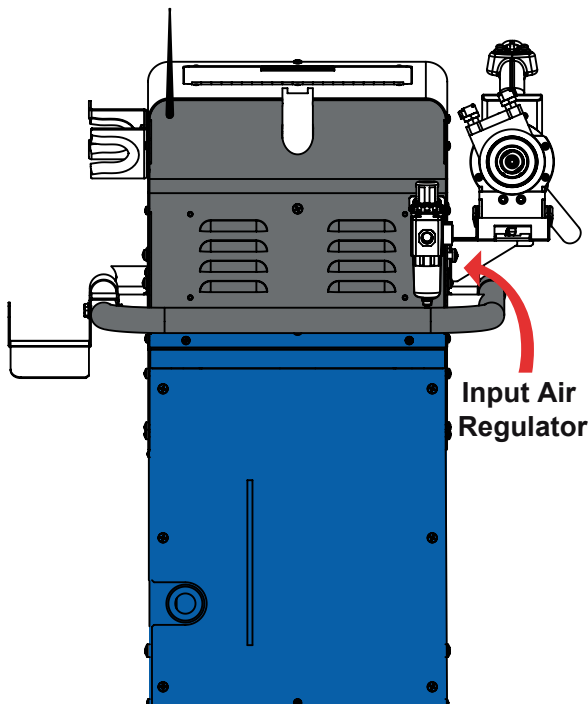

Figure 3.2

The i4s Spot Welder must be connected to a pneumatic air network (80 PSI to 130 PSI).

Connect the air supply via the 1/4 NPT input port on the input regulator at the rear of the welder using a standard connector.



IMPORTANT! The air must be clean and free from oil and moisture. Use a filter.

IMPORTANT! L'air doit être propre sans huile et humidité. Utilisez un filtre.

4.0 Operation

4.1 Before You Begin Welding

Before you begin welding, be sure to read and understand the following instructions.

The Pro Spot i4s is a state-of-the-art Resistance Spot Welder that was designed for the collision repair industry. It is important to understand the design and function of this welder before operating it.

Before you begin welding with the i4s:

Squeeze Force: The i4s double-sided gun contains an air cylinder that is capable of compressing the weld caps against the weld stack up to 1240 lbs. max (565 daN). In Auto Mode, the i4s automatically adjusts the squeeze force to maximize fusion of materials and minimize expulsion during the welding.

Energy: In Auto Mode, the i4s controls and monitors the amount of energy delivered to each weld which ultimately determines the overall quality of the weld. Perform regular destructive tests on the metal you are welding to validate the weld no matter which mode you are in.

Current: Another important aspect of a weld is the current applied through the work piece. A weld is created when the current is transferred through the layers of sheet metal. The resistance in the metal causes the area to heat up and fuse the sheets together in a nugget.

Weld Program: Maintaining the air pressure after the current shuts off makes the weld cool down under pressure resulting in a harder, stronger weld. This feature is built in to the i4s weld control program and is engaged automatically during a weld cycle.

Time: The Time controls the duration of the current applied during the weld cycle.

4.2 About Your Welder

The welder is supplied with one of the following voltage and frequency combinations:

Input Voltage: 3 phase
208-240V 50/60 Hz.
400-480V 50/60 Hz.

The actual voltage and frequency is stated on the rear panel name plate. Open circuit output voltage 20V max. E.M.C. classification is CISPR 11.

Welding Amperage: 12,500Amp max (3-phase)

Cable Length: Input 30' (10m)
Weld cable 8.75' (2.67m)

Electrode Force: 1240 lbs. max (565 daN)

Cooling System: Radiator / Pump Active Loop
Cooled to the Weld Caps

Microprocessor: i4s Wirelessly Upgradeable
Software Platform

Protection: IP 21

Shipping Weight (standard): 385 lb (175 kg)

Weld Head Weight: 26 lb (12 kg)

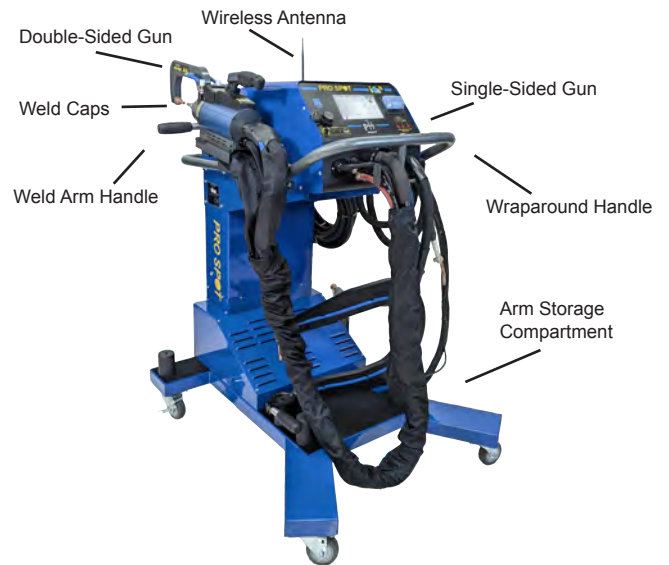
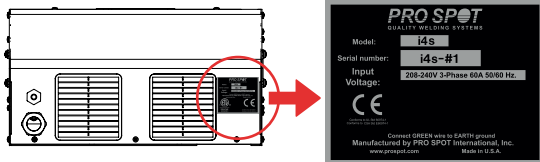

Figure 4.1 i4s-Overview



The name plate is at the rear of the welder unit. The required voltage is indicated on the label. Welding output is rated at 15V.

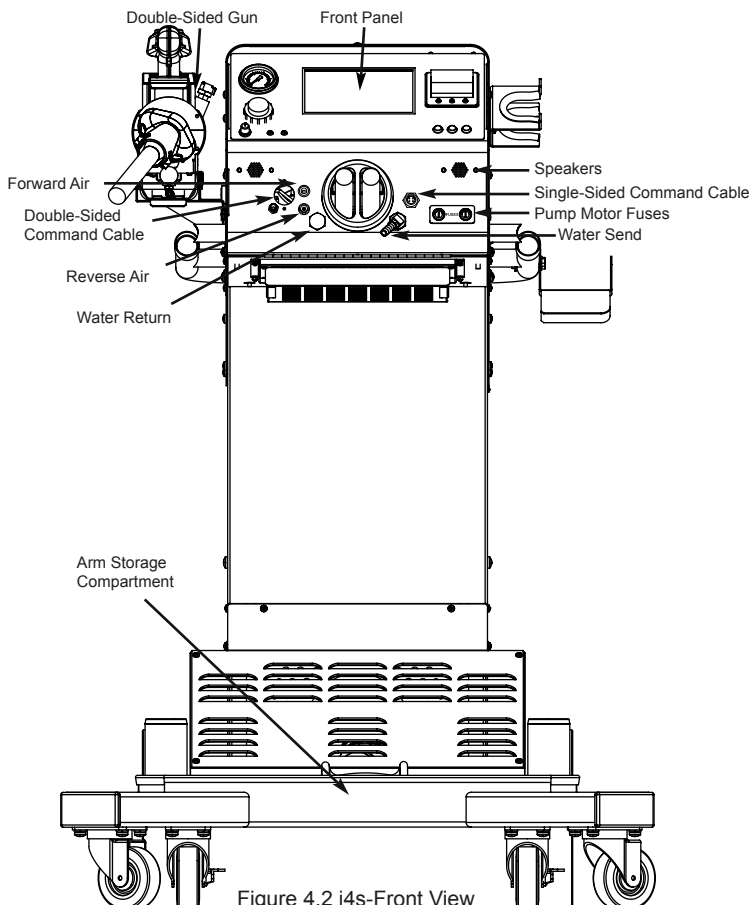

Figure 4.2 i4s-Front View

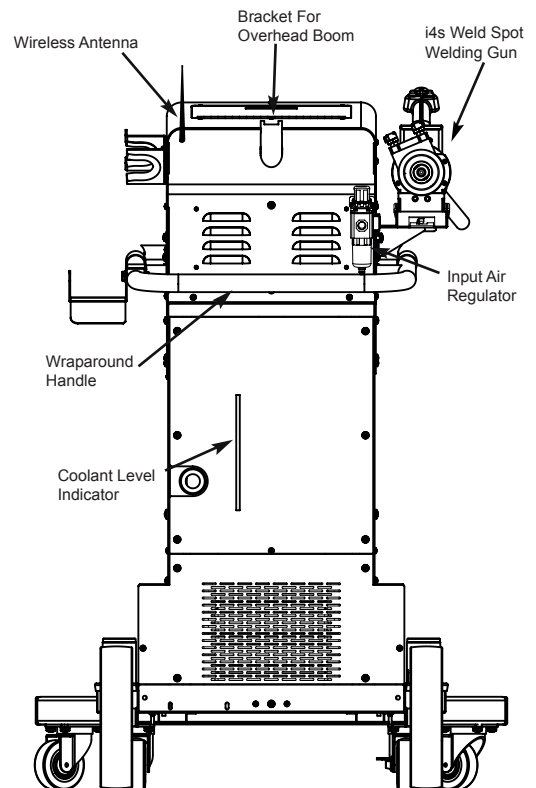

Figure 4.3 i4s-Back View

4.3 Turning On The i4s



Figure 4.4

1. The 3-phase indicator (3 LEDs on the front panel) should always be illuminated while the welder is plugged in (verify this before turning on the power). Switch the circuit breaker on the front panel to “ON”.
2. The display will go through the start-up procedure.
3. The i4s is now ready to use.



IMPORTANT! Make sure to read the instruction manual before operating the welder. Only trained personnel should use this welder.

IMPORTANT! Assurez-vous de lire le Mode d'Emploi avant d'opérer le soudeur. Seul le personnel qualifié devrait utiliser ce soudeur.

WARNING! READ THE FOLLOWING BEFORE WELDING

	<p>When in use - the i4s discharges a large magnetic field which can negatively effect medical implant devices such as pacemakers.</p>		<p>Some parts of the welder may become hot after prolonged use.</p>
	<p>When in use - The i4s discharges a large magnetic field which can negatively effect electronics and attract metal to the gun.</p>		<p>Always wear eye protection when welding. Showers of sparks will periodically fly up from the material being welded.</p>
	<p>Unplug the welder from the wall outlet before servicing, cleaning, or maintenance. Risk of electrical shock.</p>		<p>Be wary of pinch points on the i4s such as the electrodes / weld caps on the double-sided gun.</p>

4.4 How To Login

How To Login

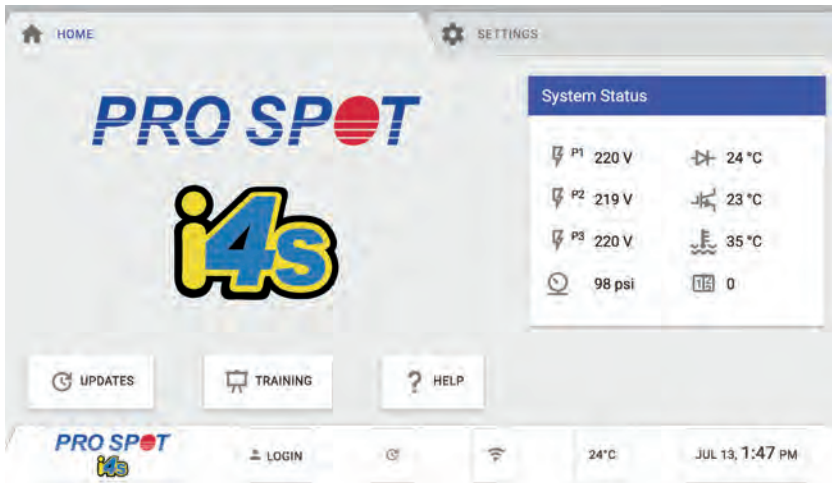

Figure 4.5

From the Home Screen, touch the Login button to login (Figure 4.5).

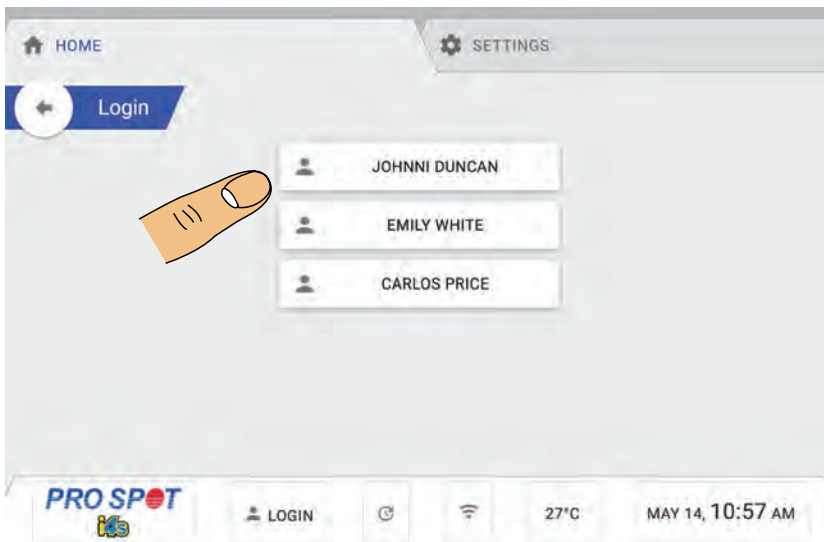

Figure 4.6

From the Login Menu, select the user account you wish to login into (Figure 4.6).

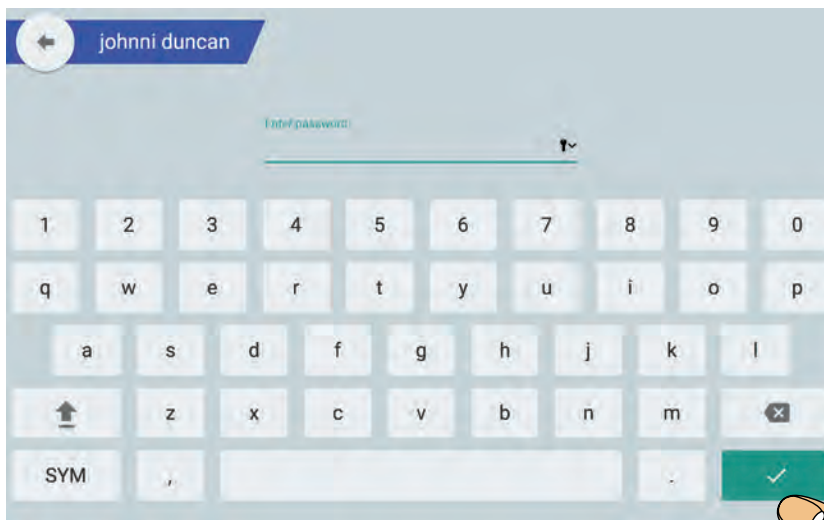
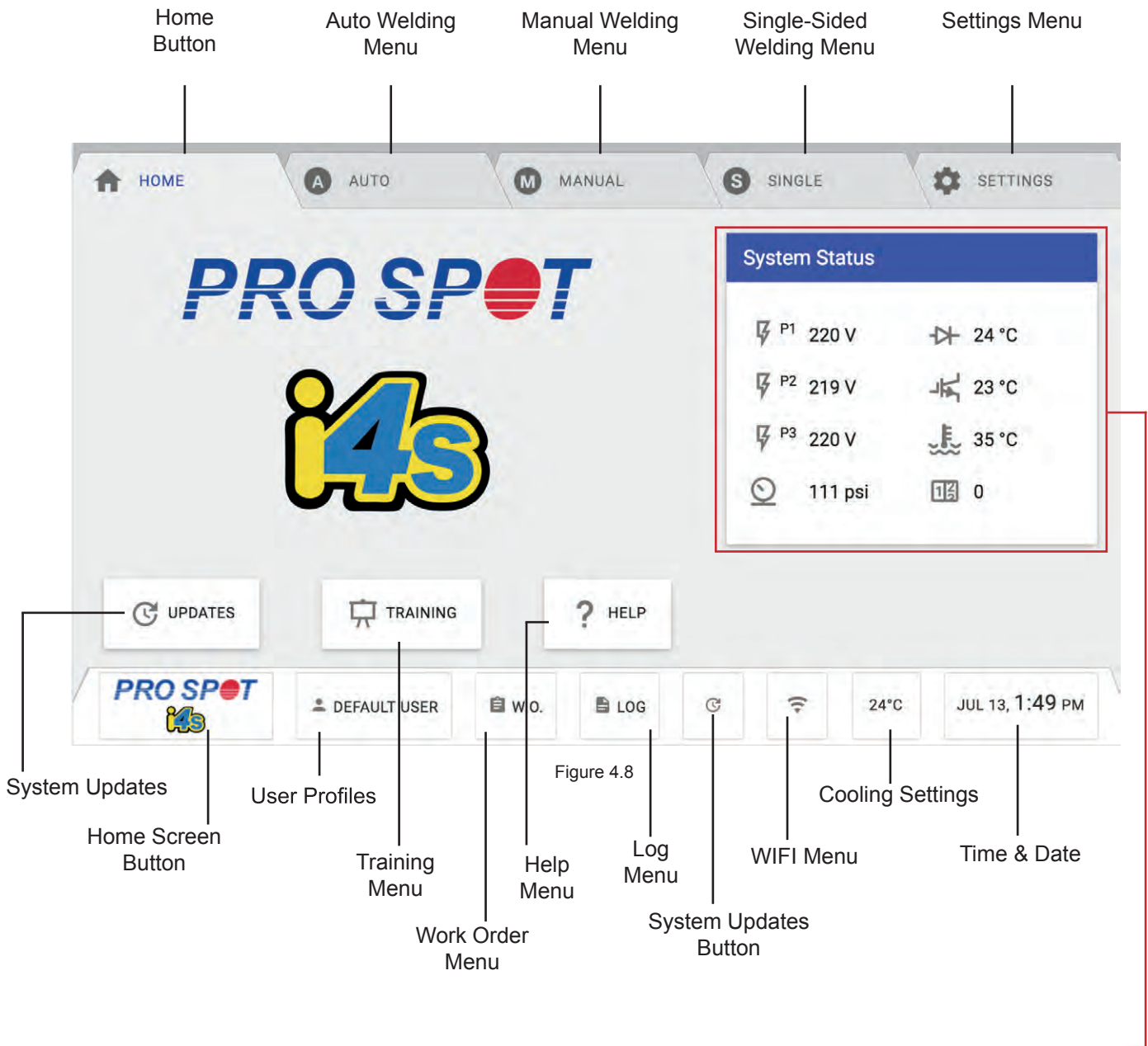

Figure 4.7

Enter the user password, then press the green check mark to continue to the i4s Home Screen (Figure 4.7).

NOTE: Default user password is - 1234

4.5 i4s Home Screen



System Updates
 Home Screen Button
 User Profiles
 Training Menu
 Work Order Menu
 Help Menu
 Log Menu
 System Updates Button
 WIFI Menu
 Cooling Settings
 Time & Date

System Status			
Phase 1 Voltage	P1	220 V	Diode Temperature
Phase 2 Voltage	P2	219 V	Stack Temperature
Phase 3 Voltage	P3	220 V	Cable Temperature
Input Pressure		111 psi	Daily Weld Counter

Figure 4.9

4.6 i4s General Settings Menus

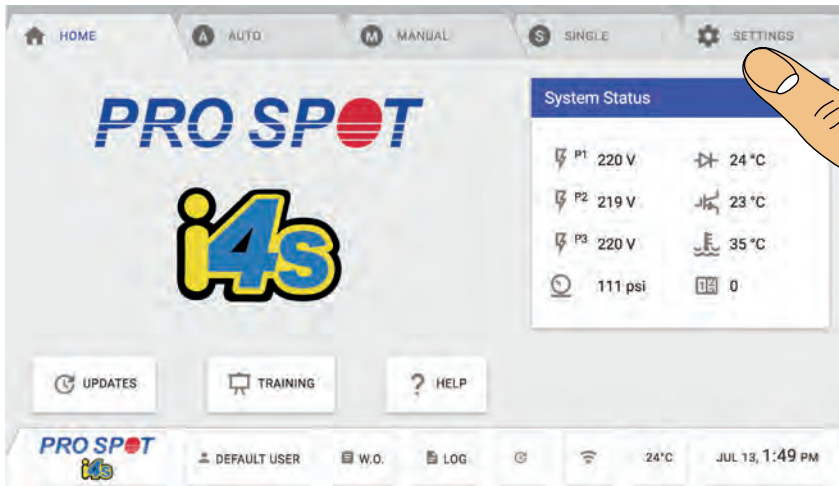

Figure 4.10

To access the i4s System Settings Menu, select the Settings tab on the top right of the screen (Figure 4.10).

WIFI Menu



Figure 4.11

The WIFI Menu will let you connect to any wireless network available in your area. Select the network you wish to connect (Figure 4.11).



Figure 4.12

After selecting your network, you will be prompted to enter the network password (Figure 4.12).

Cooling Menu

The Cooling Menu allows the user to manually configure the air cooling. By default, the single and double-sided air will turn on automatically once the machine reaches a certain temperature. The Single Sided Air slider turns the air for single sided welding on or off. The Double Sided Air slider turns the air for double sided welding on or off. The Water Pump button turns the water pump on or off.

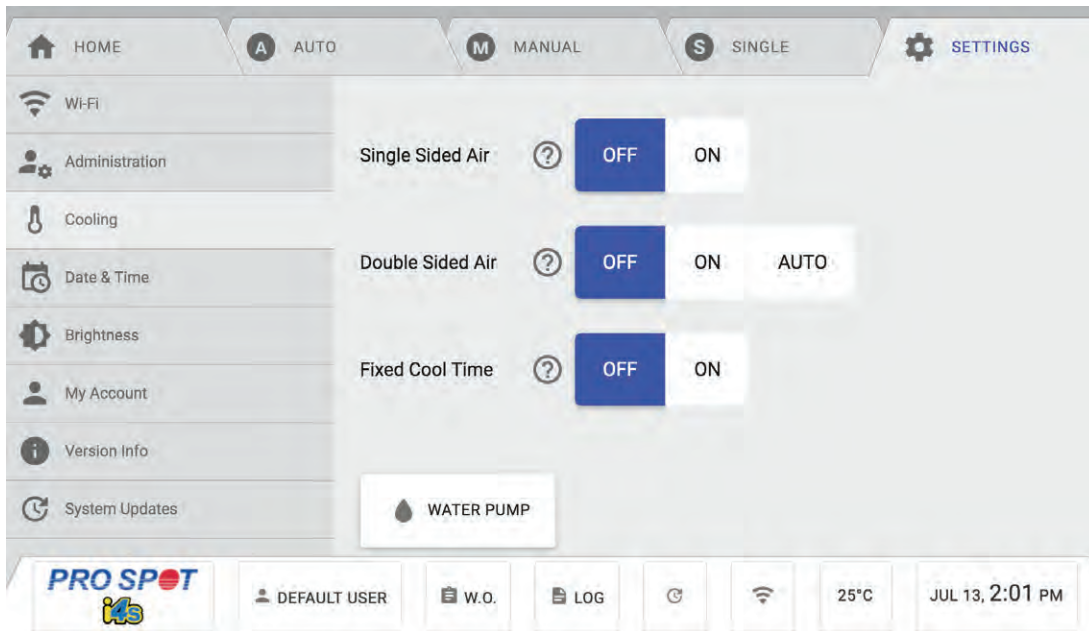

Figure 4.13

The Single Sided Air and Double Sided Air Cooling are switched on/off by sliding the toggle buttons (Figure 4.13).

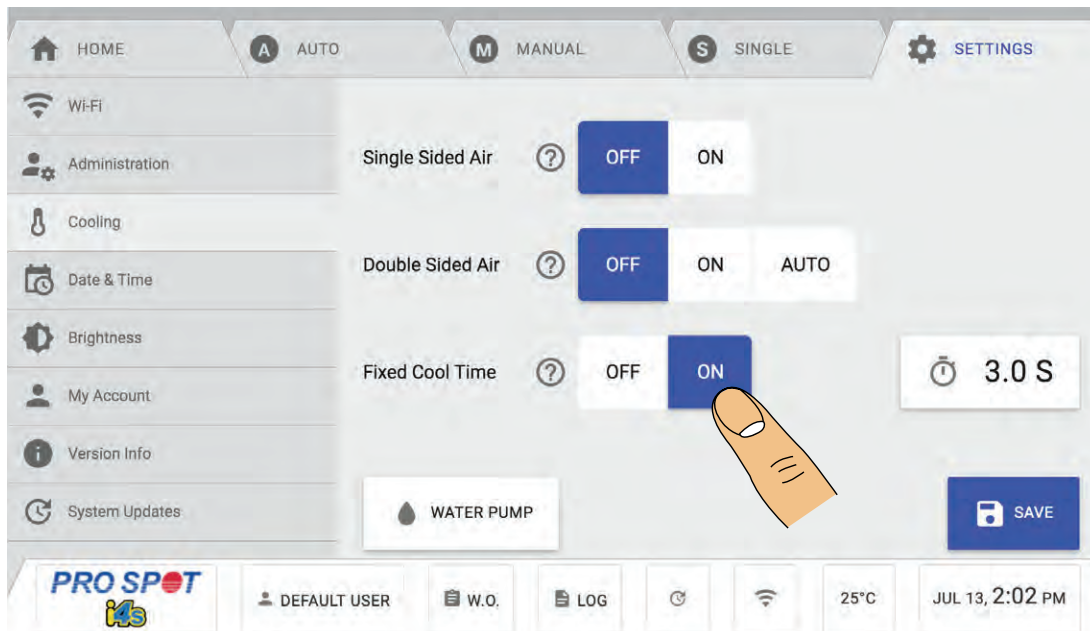

Figure 4.14

By default, the slider is set to the left which mean Optimized Cool Time is active. With Optimized Cool Time enabled, the machine will set the cool time automatically based on several performance-related parameters in order to optimize the duty cycle. When the slider is set to the right, Fixed Cool Time (Figure 14) is enabled and there is a cool time parameter you can set. If the time is set to 3.0s, that means you will need to wait 3 seconds after a weld has been completed before you can weld again.

Date & Time Menu

The Date & Time Menu allows the user to set the time and date. It also allows the user to choose whether they wish to see a 12 Hour or 24 Hour Clock display by selecting the Change Display Unit button (Figure 4.15).

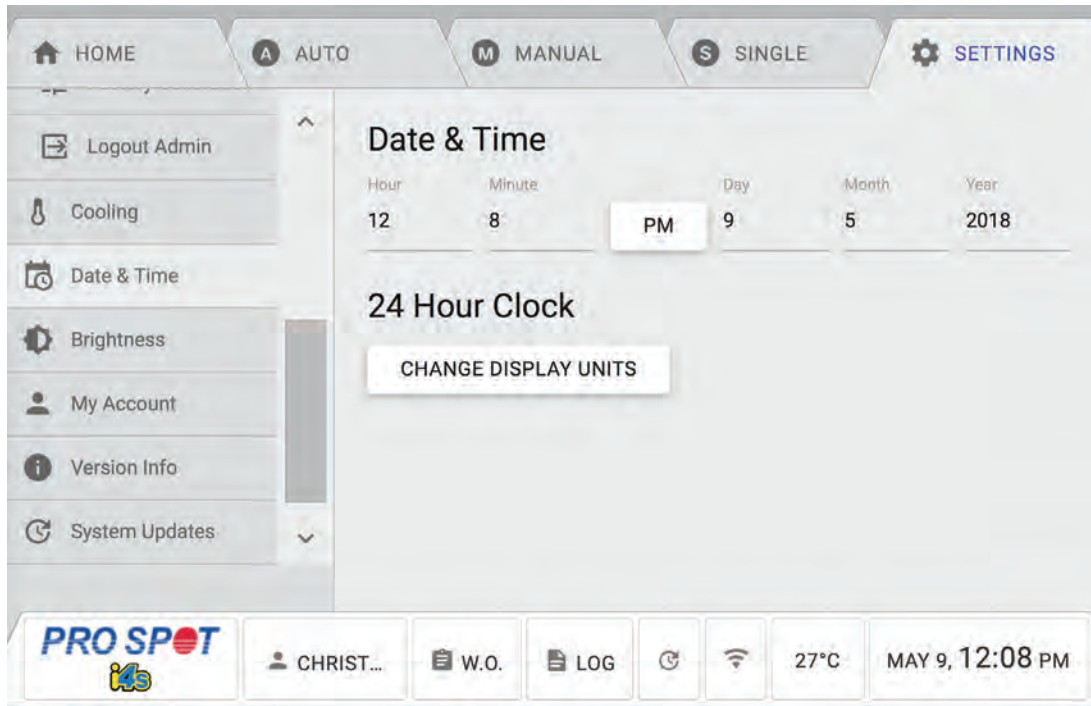

Figure 4.15

Brightness Menu

The Brightness Menu allows the user to select the brightness level of the LCD screen with a range between 20-100 (Figure 4.16).



Figure 4.16

My Account Menu

Under the My Account Menu you will find the Change Password Menu and the Preferences Menu.

Change Password Menu

In the Change Password Menu you are able to change your User Profile Password (Figure 4.17).

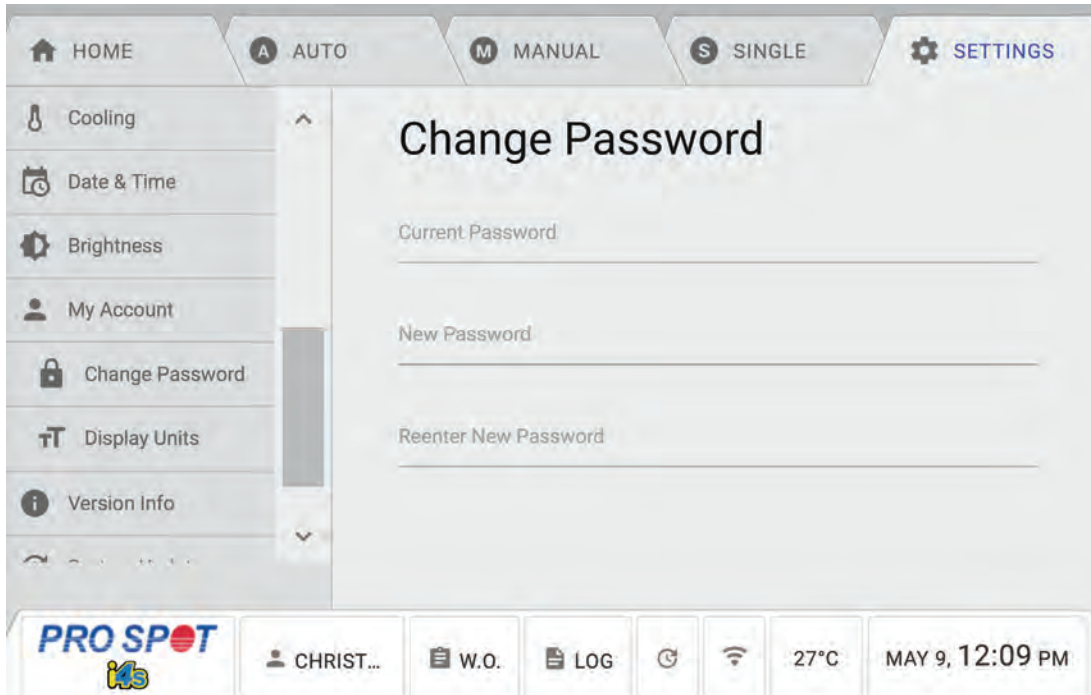

Figure 4.17

Preferences Menu

In the Display Units Menu you are able to change the way the machine displays temperature, Celsius or Fahrenheit, and the clock settings, 12 Hour or 24 Hour (Figure 4.18).

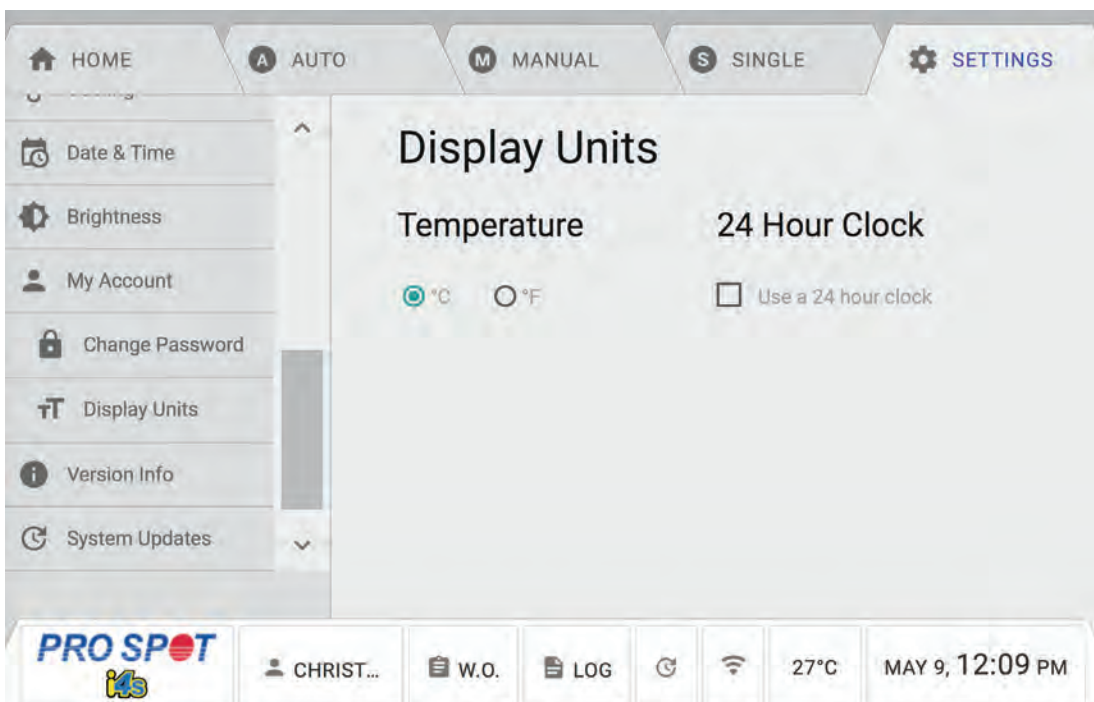

Figure 4.18

Version Info Menu

The Version Info Menu displays the hardware versions the machine has. This information may be useful when looking to see if your machine is up to date (Figure 4.19).



Figure 4.19

System Updates Menu

The System Update Menu allows you to check for software updates and to download the latest updates from Pro Spot. It also displays the Update History of the machine. After the update is done downloading, press the Install Updates button. The machine will automatically reboot and install the new software (Figure 4.20).

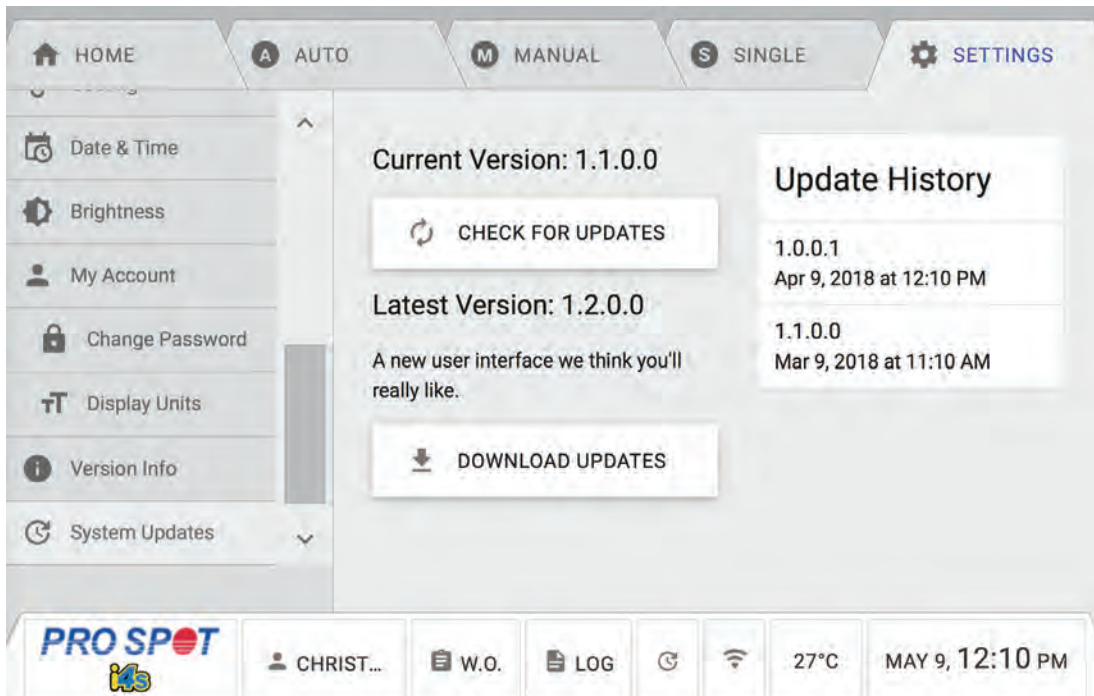

Figure 4.20

4.7 i4s Administration Settings Menus

To access the Administration Settings:

1. Select the Settings tab.
 2. Once you're on the Setting tab, select Administration (Figure 4.21).
 3. Once you see the Administration Menu, you will be prompted with a password screen (Figure 4.22).
 4. Enter the password to get access to the Administration Menus. NOTE: Administration Password: asdf (lowercase)
- NOTE: As a safety precaution, the Administrators access logs out after 2 minutes.

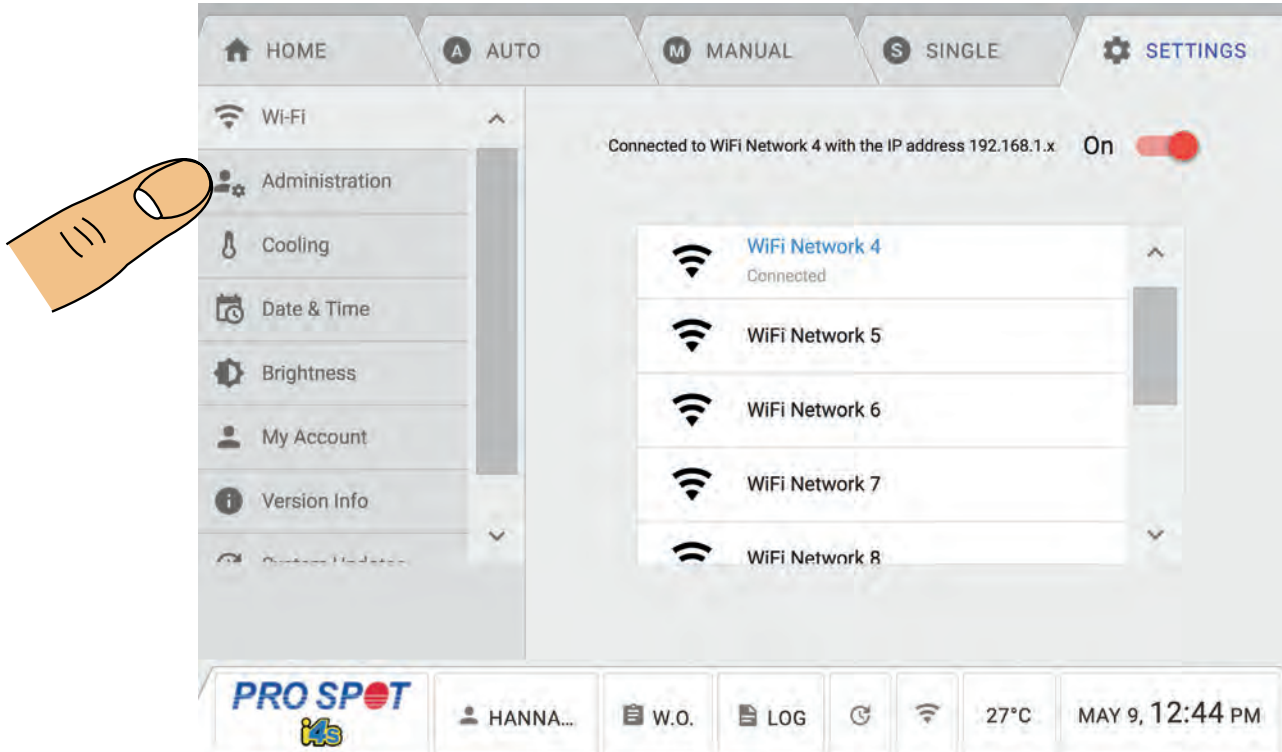

Figure 4.21



Figure 4.22

ADMIN: Work Orders

The Work Orders Menu allows you to create work orders which correspond to each individual job. While a work order is active, each weld that is performed will be logged and associated with that specific work order. After creating a work order, it can be assigned to a technician. Once it has been assigned, it will pop up when that technician logs in. When you export the work order, all of the weld information will come with it.

Create A Work Order:

1. The first time you enter the Work Order Menu it will be empty.

NOTE: After entering work orders, the menu will show the previous work orders you have entered (shown below).

2. To create a new work order, select Add New Work Order. This is the red button with a plus sign (Figure 4.23).

3. Once you press the Add New Work Order Button, a menu will pop up and let you enter in the work order information (Figure 4.24).

4. Once you have entered in all the information, hit ADD to continue.



Figure 4.23

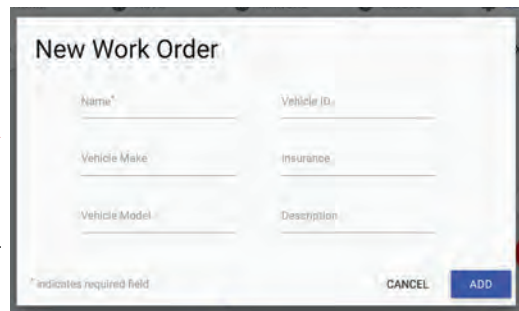

Figure 4.24

Assign A Work Order:

1. To assign someone to the work order, select the work order you wish to assign.

2. On the top right-hand side of the work order you will see four options - Remove, Log, Export and Assign (Figure 4.25).

3. Select the Assign option.

4. From the Users List, select the User you wish to assign the work order to (Figure 4.26).

5. Once you have selected the user, press the button that says Assign.

6. Once they have been assigned, you will be taken back to the Work Order Menu.

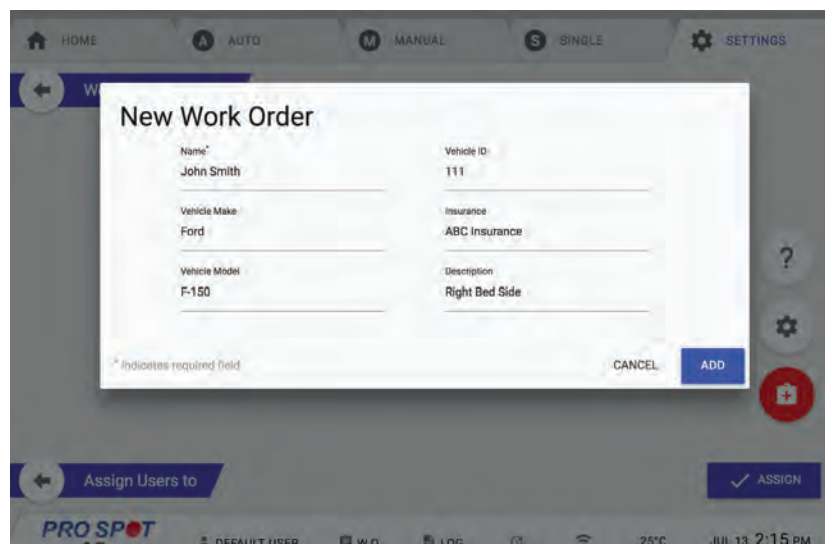

Figure 4.25

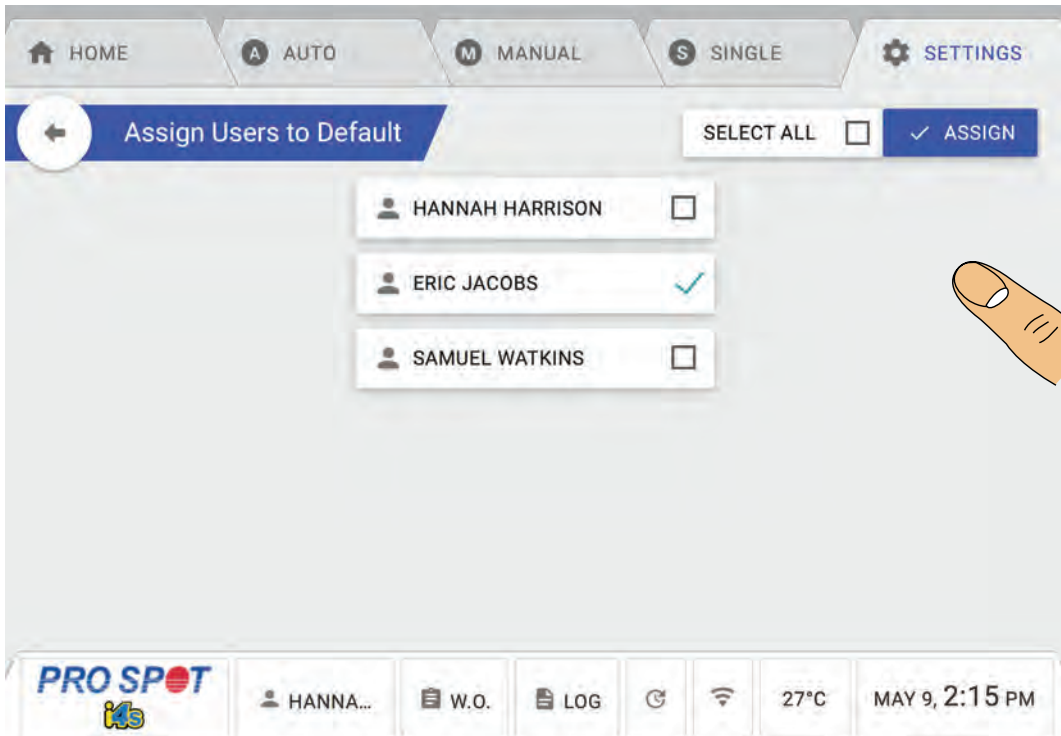

Figure 4.26

Make A Work Order Active:

Make A Work Order Active: Once work orders are assigned to a particular user login, the user would login with their username and then press the W.O. button in the lower status bar. The user will be presented with a list of work orders including the default work order. The green star next to the default work order indicates that the default work order is active (Figure 4.27). When a work order is active, it means that, every weld performed is logged into that active work order. If the user needs to make a different work order active, they simply press the work order they wish to make active and press the Make Active button.

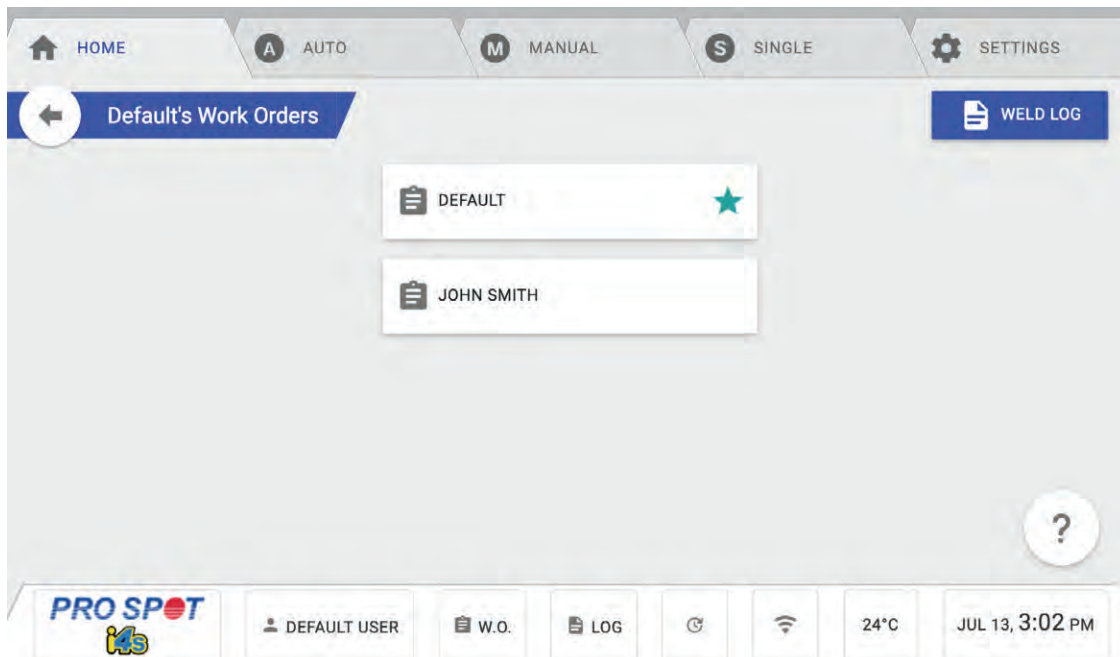

Figure 4.27

Export A Work Order:

Once the work order has been completed, the information can be exported via Email or USB.

1. Select the work order you wish to export from the Work Order Menu and press Export in the top-right.
2. Once you press the export button you will be taken to the Export Work Order prompt (Figure 4.28).
3. You have two choices on how to export the work order: Export to Email and Export to USB.
4. Select your option and export.
5. If using the Export to Email option, the Select Email button takes you to a list of previously entered emails, or you can manually enter any email address then Export.

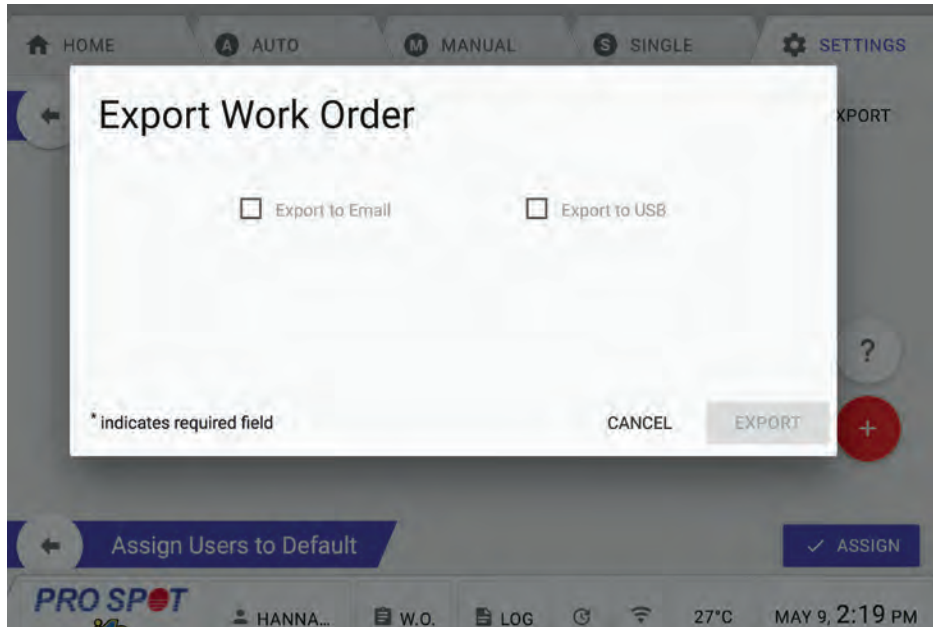

Figure 4.28

How To Allow Users To Add Work Orders:

1. Navigate to the Work Orders Admin Menu (Figure 4.29).
2. Select the Settings Button located above the Add Work Order Button.
3. This will bring up the Work Order Settings (Figure 4.30).
4. To select the option to allow users to add work orders, toggle the button to the right (it will turn green) and press the Save Button (Figure 4.32). To turn off the option, toggle the button to the left.
5. Now when users access the Work Orders Menu they will also have the option to add work orders. You can see if this feature is activated by the red Create Work Order Button located on the bottom-right. (Figure 4.32).

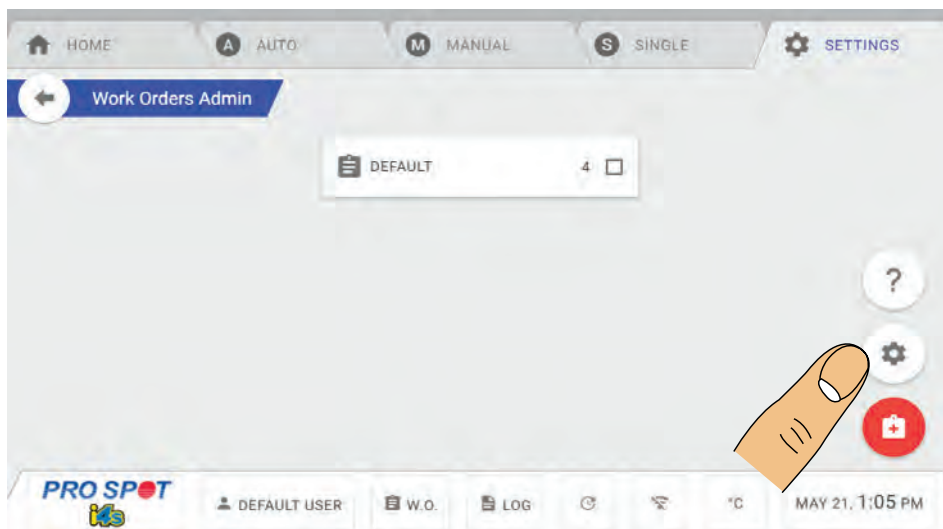

Figure 4.29

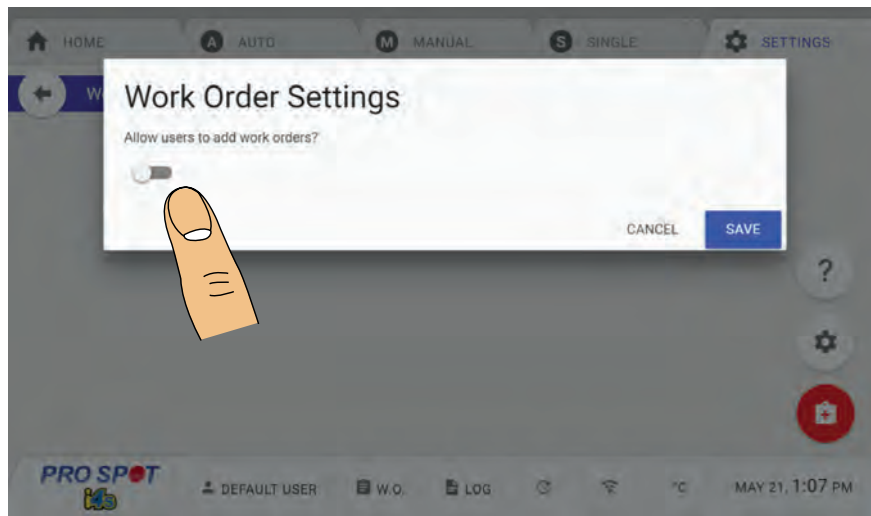

Figure 4.30

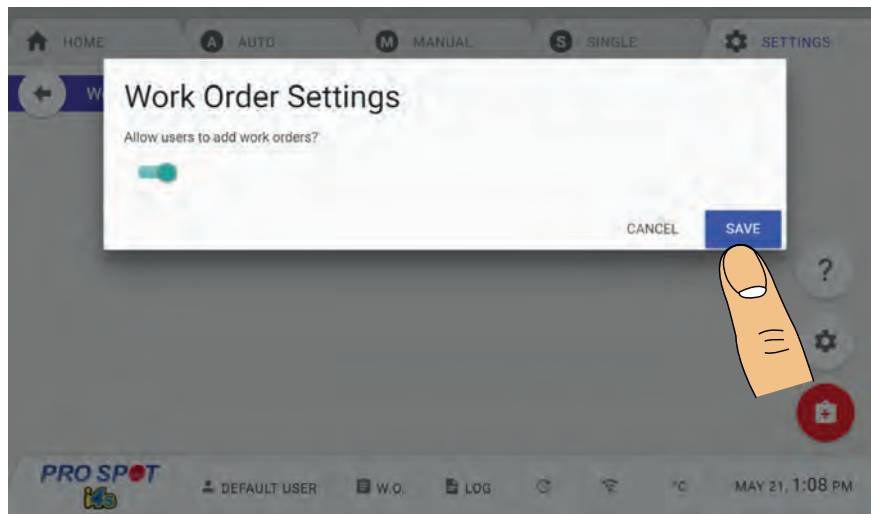

Figure 4.31

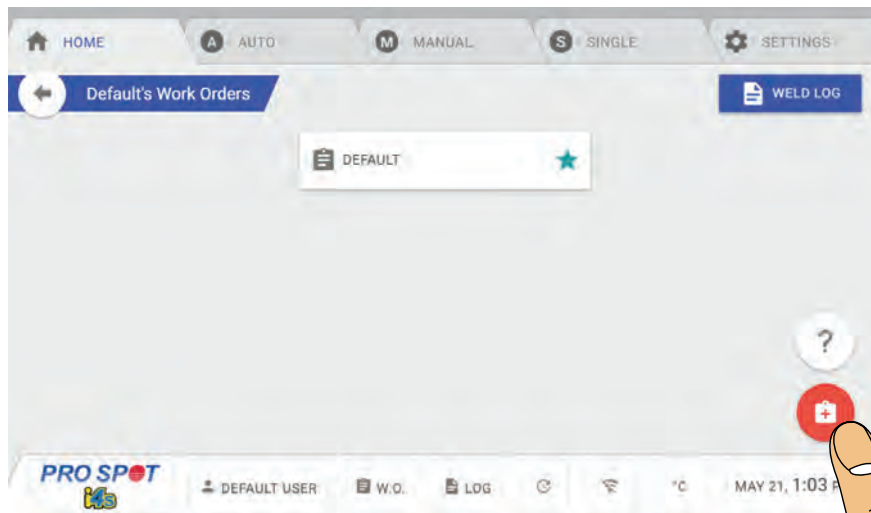

Figure 4.32

ADMIN: User Menu

In the User Menu, the Administrator can add, edit and remove user profiles.

Add A New User:

1. Navigate to the User Menu and select the red Create User Button in the bottom right (Figure 4.33).
2. Once you select Create User, a new user prompt will pop up and ask you for the New User details (Figure 4.34).
3. Enter the user's information and determine their user level - Basic, Standard or Advanced. Then press the Add button to add the user.

Basic User Settings: Not permitted to change any advanced settings.

Standard User Settings: Permitted to change advanced settings.

Advanced User Settings: Permitted to change Auto Mode advanced settings.



Figure 4.33



Figure 4.34

How To Edit or Remove A User Profile:

1. Navigate to the Users Menu and select the user you want to edit or remove.
2. The Edit User Menu will pop up (Figure 4.35), where you can edit or remove the profile.

Edit a User Profile:

1. Select any field you wish to edit.
2. Once your edits are done, hit save.

Remove a User Profile:

1. Press the Remove User button located on the top right-hand side, then hit save.

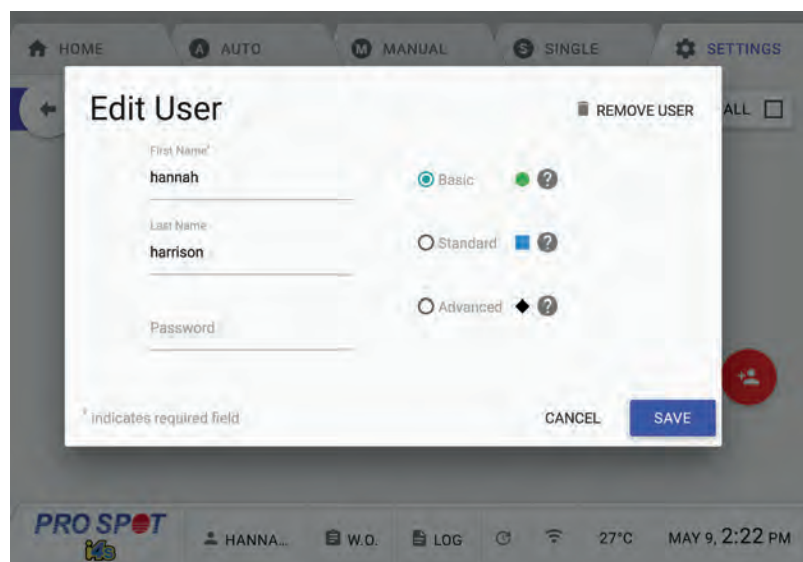

Figure 4.35

Alerts Menu

The Alerts Menu allows users to adjust the Current Tolerance, Idle Line Voltage and Weld Line Voltage (Figure 4.36).

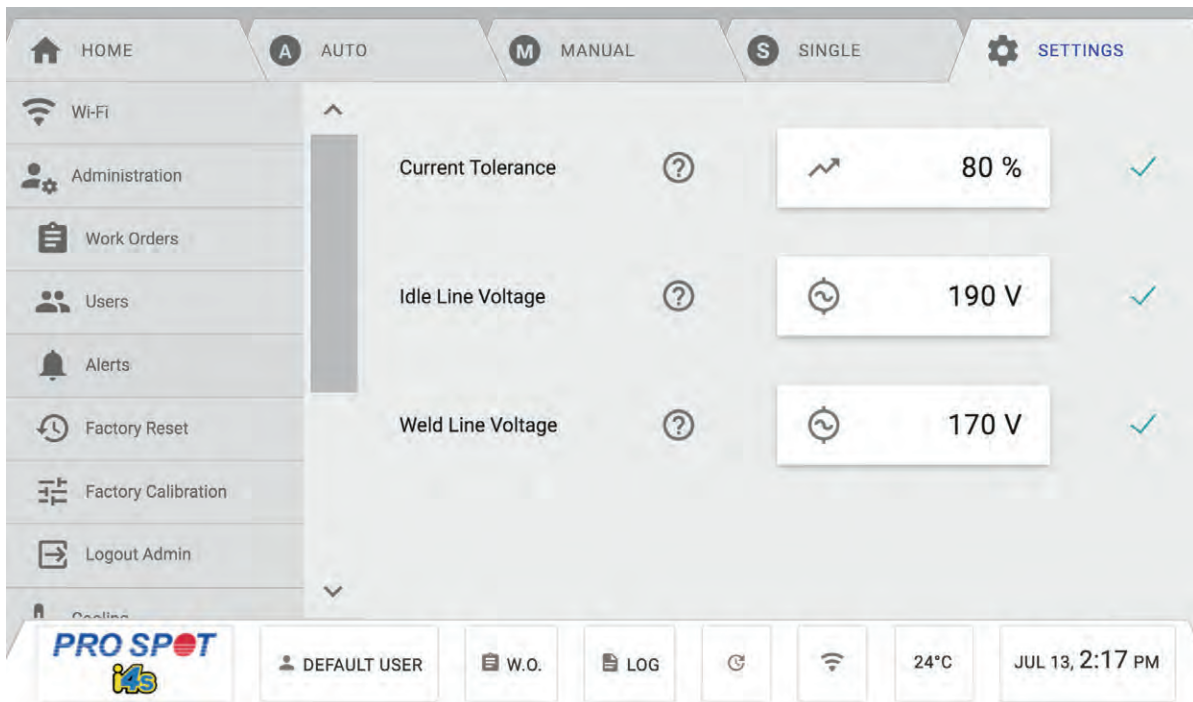

Figure 4.36

Factory Reset Menu

The Factory Reset Menu will give you the option to reset weld programs, user preferences, system alerts and a complete factory reset (Figure 4.37).

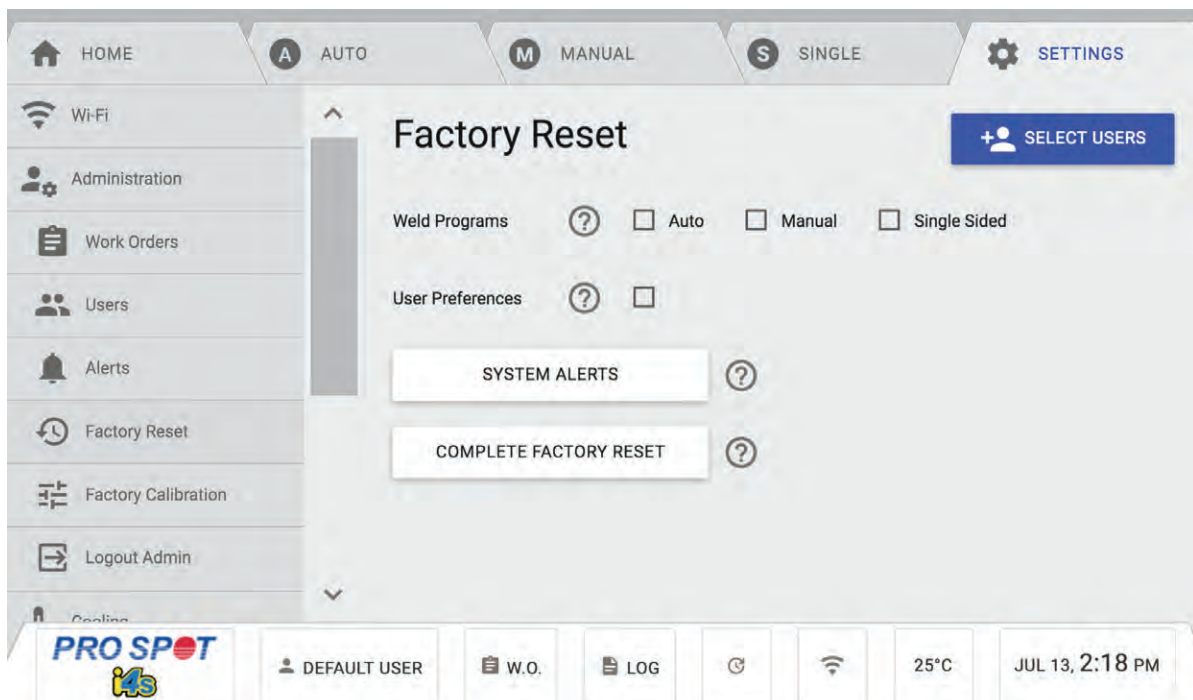

Figure 4.37

To Reset:

1. Select the feature you wish to reset.
2. Once you have selected one of the options listed above, press the Reset button.

Checking the Auto checkbox resets all of the Advanced Auto Weld Settings to Factory Default for the selected users. Checking the Manual checkbox resets all of the Advanced Manual Settings and material presets to Factory Default for the selected users.

Checking the Single Sided checkbox resets all of the Advanced Single Sided Settings and single sided adapter programs to Factory Default for the selected users.

Checking the User Preferences checkbox resets all of the User Preferences settings for the selected users.

The Select Users button allows you to select which users you want the Factory Reset to affect. You can either select specific users by pressing each user or you can select all users by pressing Select All. Selected users will have a green checkmark next to their name. Once you have chosen the users, press the Select button to confirm your selection.

After configuring the Factory Reset options, you can press the Reset button to perform the Factory Reset.

There are also 2 other reset options: System Alerts and Complete Factory Reset. Pressing the System Alerts button resets the Alerts settings under the Administration menu in Settings. Pressing the Complete Factory Reset button restores the welder to factory defaults.

Factory Calibration Menu

The Factory Calibration provides the ability calibrate the machine to optimal performance. This should only be performed by authorized Pro Spot personnel.

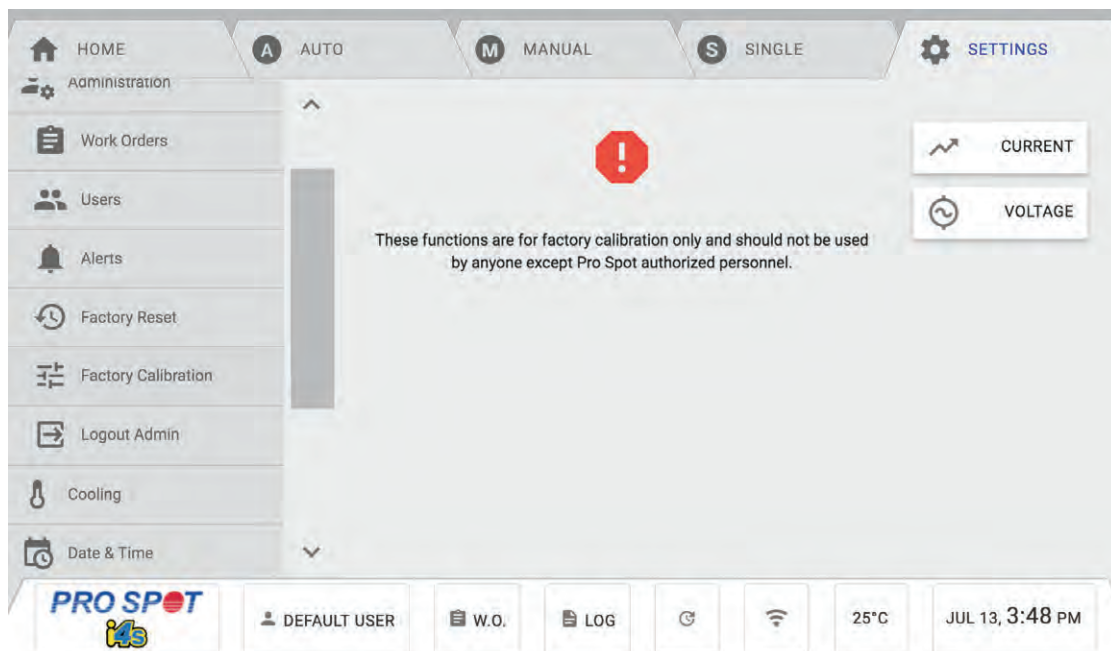

Figure 4.38



WARNING! These functions are for factory calibration only and should not be used by anyone other than authorized Pro Spot personnel.

Voltage Calibration

The Voltage Calibration will help users measure the AC voltage between phases with a multimeter. This should only be performed by authorized Pro Spot personnel.



WARNING! These functions are for factory calibration only and should not be used by anyone other than authorized Pro Spot personnel.

5.0 Double Sided Welding Programs

Auto Mode on the i4s automatically detects the thickness and resistance of the weld stack up. Once properly calibrated, the user only needs to press and hold the weld trigger and the top right button on the gun and the i4s will determine the correct power levels and duration.



IMPORTANT! Make sure the water cooling hoses are securely clipped into place before welding.

IMPORTANT! The i4s welder comes without coolant to ease transportation, be sure to fill the coolant tank before turning on the welder.



IMPORTANT! If the thermal breaker has switched off the welder, please contact Pro Spot's authorized service personnel.

IMPORTANT! N'éteignez pas le soudeur pendant que le système de refroidissement est activé!

IMPORTANT! Si le disjoncteur thermique a éteint le soudeur, s'il vous plaît contactez personnel de service autorisé Pro Spot.

5.1 Auto Mode Menu Guide

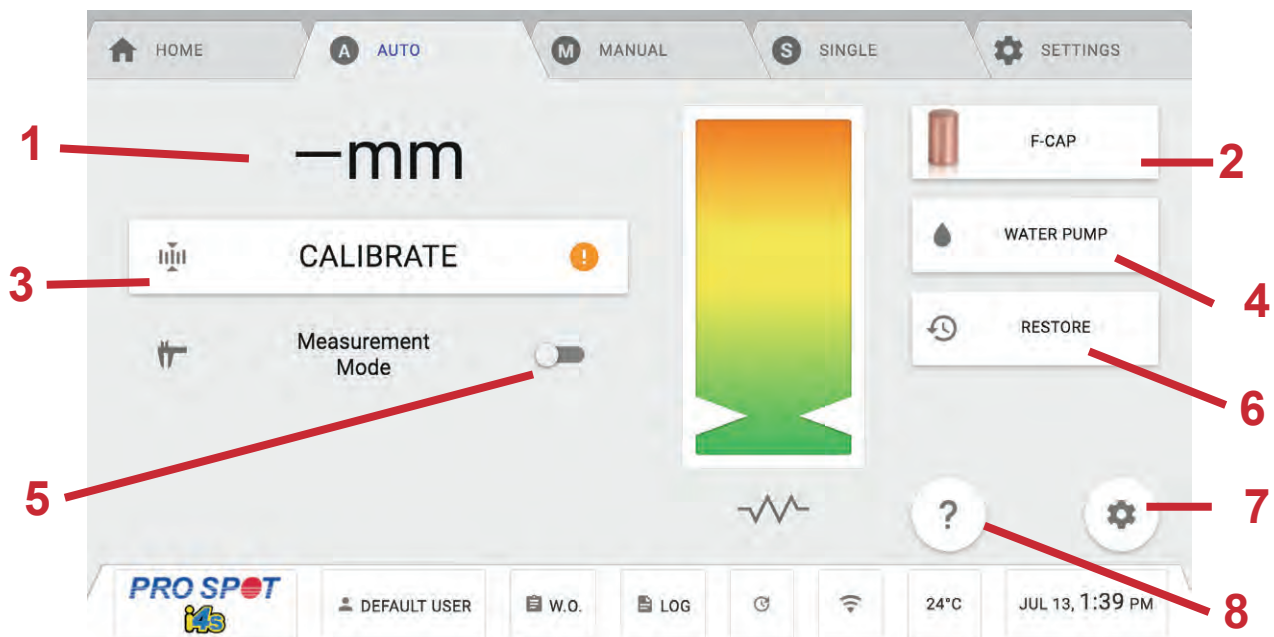

Figure 5.1

1. Thickness Measurement - This displays the thickness in millimeters of the material between the tips when welding.

2. Weld Cap - This button provides selection of 3 different weld cap profiles: A-Cap, B-Cap, and F-Cap (default). The presets are all unique to each cap so an HSS 0.7mm setting while the A-Cap is selected will be different than with the B-Cap or F-Cap selected.

3. Calibrate - This button starts the calibration process which is necessary in order to use Auto Mode. Follow the on-screen instructions to calibrate. You will need to do this in the following scenarios:
 - a. every time you enter Auto Mode
 - b. when a weld cap is changed and the weld cap setting is changed
 - c. when an arm is changed
 - d. periodically as your weld caps get more worn
 - e. every 100 welds
 - f. any time you notice the thickness measurement is not accurate

4. Water Pump Shutoff - This button allows the user to temporarily disable the water pump so that an arm or weld caps can be changed on the PS-700W weld gun. Refer to section 7.2 for changing arms and section 8.1 for changing weld caps before doing so. The screen will prompt a countdown for you to wait, after it expires, you can make your necessary changes to the Weld Gun. After the change is complete, you can press DONE to continue and the water pump will turn back on.

5. Measurement Mode - This slider toggles the welder between Auto Weld Mode and Measurement Mode. The slider in the Figure 2 is in Auto Weld Mode. When pressed, it will slide to the right and turn red. A message will show up on the screen notifying the user that they are now in Measurement Mode. Measurement mode applies a small current through the workpiece allowing the machine to measure the thickness without welding. To return to Auto Weld Mode, simply press the slider again.

6. Restore Button - This button will restore your weld settings.

7. Auto Weld Advanced Settings - This button allows the user to change the parameters that affect Auto Mode. You will need the admin password in order to access these settings. **WARNING:** Contact Pro Spot technical support before modifying any of these settings.

8. Auto Weld Help - This button shows the user help information that applies to the Auto Weld screen.

5.2 Auto Mode - Measurement Only Mode

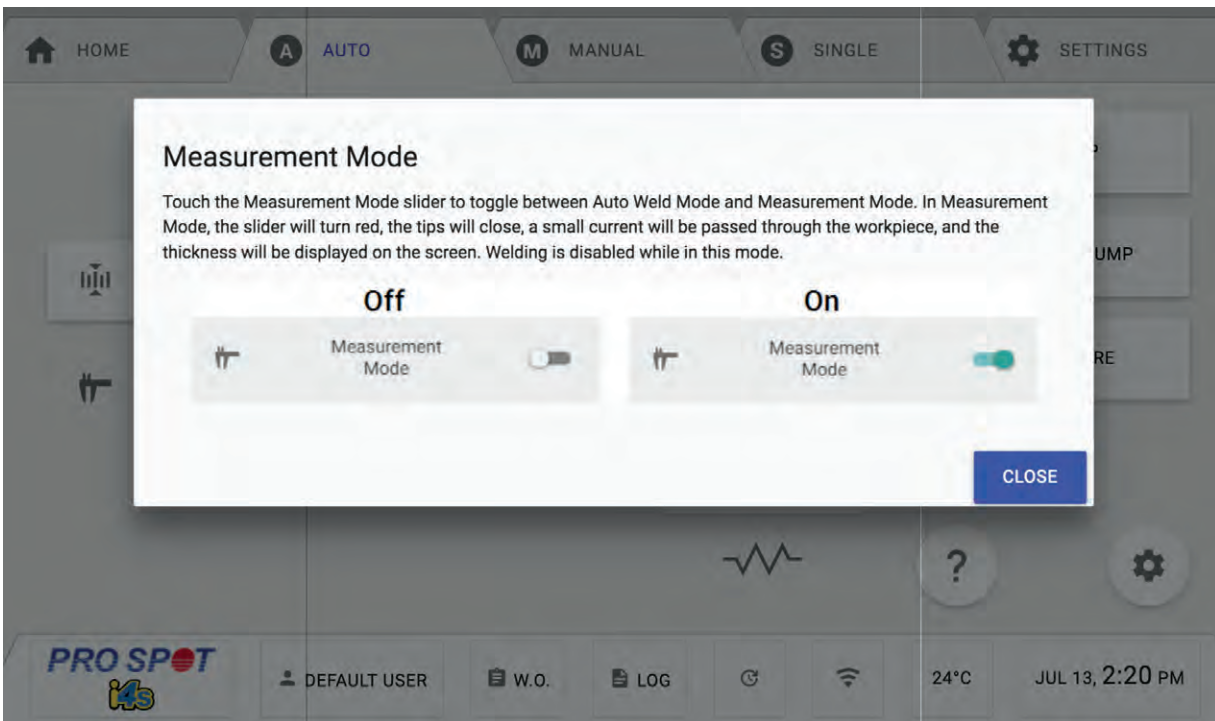

Figure 5.2

The user can also access the Auto Mode screen to select Measurement Only Mode, which measures the steel thickness and resistance without welding (Figure 5.2).

5.3 Auto Mode Calibration

Auto Mode Calibration zeroes out the measurement system to prepare it for an Auto Weld. Start the Calibration process by pressing the Calibrate button on the screen.



CAUTION: During the calibration test cycle, the electrodes will close, creating a pinch point that will cause injury. **Do not calibrate with metal between the electrodes!**

1. Press and hold the Release Trigger Button to open electrodes wide.

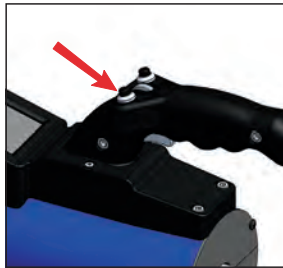

2. Press and hold both, the Weld Trigger and top right button on the gun to close electrodes.



Be sure to calibrate in Auto Mode:

- Every 100 welds
- Every arm exchange
- Every time Auto Mode is entered
- You can NEVER calibrate too often!

CAUTION: Only “OEM” and “Radius Nose” weld caps should be used in Auto Mode.



Figure 5.3

After each weld, the measured thickness feedback will be displayed on the screen (Figure 5.3).

After a weld has been completed, the Weld Feedback screen will appear.

- If the weld was performed correctly, you will automatically return to the Auto Weld screen.
- If there was a problem with the weld, the screen will display what went wrong.
- Follow I-Car Uniform Procedures For Collision Repair WE51S Squeeze-Type Resistance Spot Weld and always perform routine test welds followed by destructive testing.

Settings:

The Settings button can be used to modify weld settings. Only users at the advanced and expert levels are permitted to access Weld Mode settings.

WARNING: It is NOT recommended that factory settings be modified.

Measurement Only Mode:

The Caliper icon sets the i4s to Measurement Only Mode. While in Measurement Only Mode, the Caliper icon will be highlighted in green.

Measurement Only Mode allows you to measure the thickness and resistance of steel without welding it.

5.4 Manual Mode Welding Menu Guide

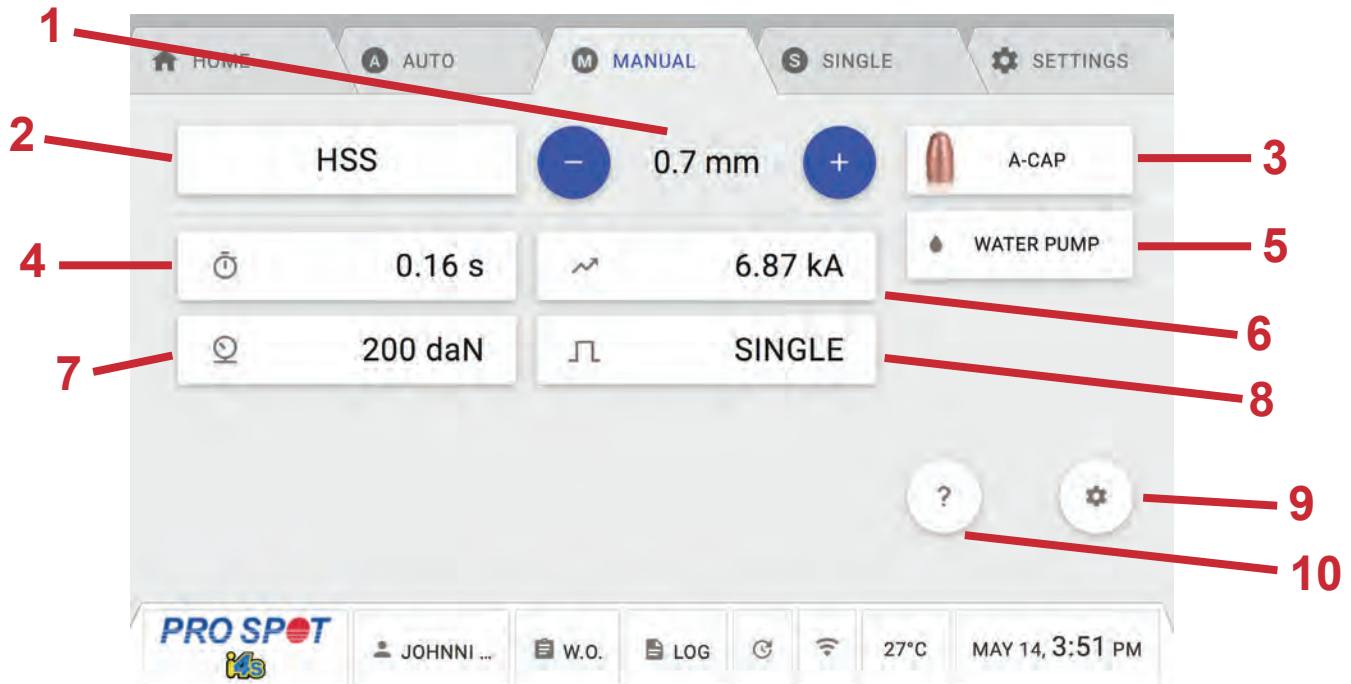

Figure 5.4

1. Weld Thickness - This button provides selection of 6 different weld thickness (0.7, 1.0, 1.2, 1.5, 2.0, 2.5 mm). The thickness setting is chosen by the thickest layer in your weld stackup. Remember: Satisfactory weld settings are always determined by vehicle OEM instructions and destructive testing.
2. Weld Material - This button provides selection of 4 different materials (HSS, Mild Steel, Weld Bond, Boron) as well as a Custom setting for you to create your own presets.
3. Weld Cap - This button provides selection of 3 different weld cap profiles: A-Cap, B-Cap, and F-Cap (default). The presets are all unique to each cap, therefore, an HSS 0.7mm setting while the A-Cap is selected will be different than with the B-Cap or F-Cap selected.
4. Weld Time - This button allows the user to adjust the amount of time that the welder provides current.
5. Water Pump Shutoff - This button allows the user to temporarily disable the water pump so that an arm or weld caps can be changed on the PS-700W weld gun. The screen will prompt a countdown for you to wait, after it expires, you can make your necessary changes to the Weld Gun. After the change is complete, you can press DONE to continue and the water pump will turn back on.
6. Weld Current - This button allows the user to change the current anywhere between 1.00 kA and 13.00 kA. Keep in mind, the current output will be determined by the power installation in your building.
7. Electrode Force - This button allows the user to adjust the force applied at that tips of the weld gun. The units are daN also known as dekanewtons. This setting can be adjusted between 160 and 600 daN. Keep in mind, the force the welder is able to reach is based on the input supply pressure from your compressor. See Figures 8 and 9 for the necessary input supply pressure to your machine.
8. Weld Type - This button allows the user to change between 3 different weld types: Single, Dual, and Pulse.
Single: The welder attempts to provide the set weld current for a set amount of time.
Dual: The welder attempts to provide a set preheat current for a set amount of time and then a set weld current for a set amount of time. This may be used for coated steels or weld bonding applications. See section 5.5 below.
Pulse: The welder attempts to provide the set weld current for a set amount of ON time with a set of amount of OFF time pauses in between for a set number of repetitions. See section 5.6 below.

9. Manual Weld Advanced Settings - This button allows the user to change Squeeze Time, Hold Time, Rise Time, and Fall Time. You will need the Administrator password in order to access this setting.
 Squeeze Time: The amount of time between when the weld trigger is pressed and held and when the weld current is provided.
 Hold Time: The amount of time between after the weld current stops and the electrode releases the workpiece.
 Rise Time: The amount of time it takes for the welder to reach full current.
 Fall Time: The amount of time it takes for the welder to fall down from full current to 0.

10. Manual Mode Help - This button shows the user help information that applies to the Manual Mode Weld screen.

i4s Input Pressure (psi) Required For Output Force

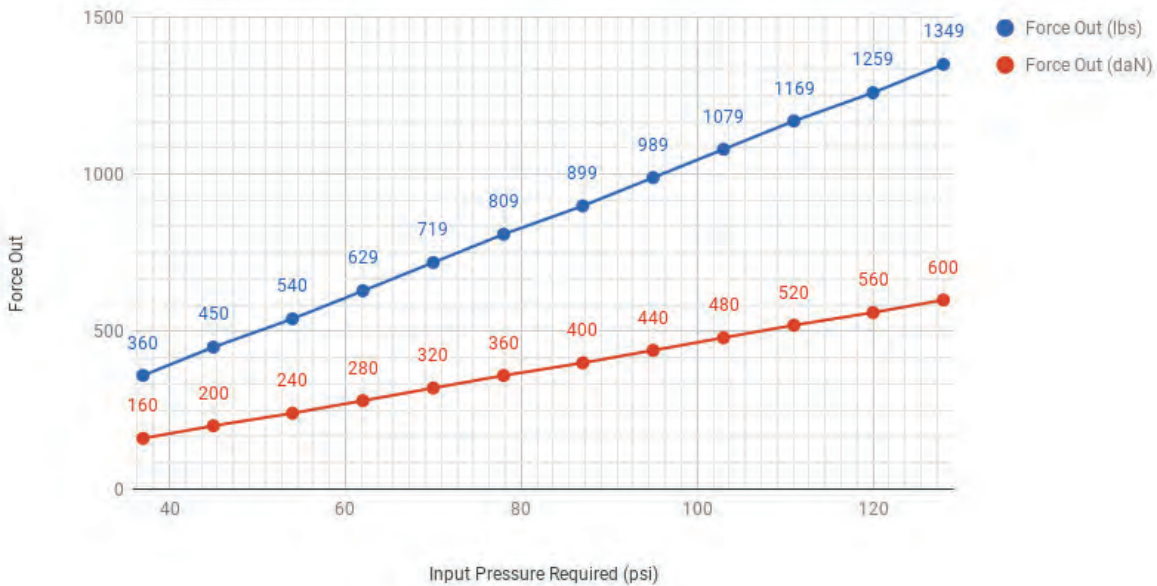

Figure 5.5

i4s Input Pressure (bar) Required For Output Force

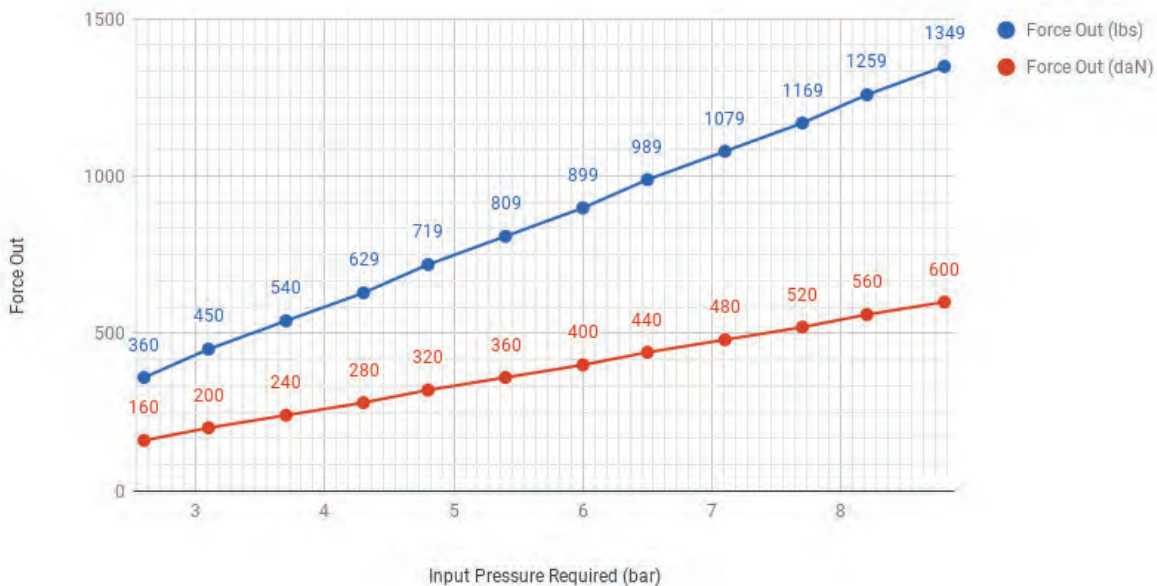

Figure 5.6

5.5 Double Sided Welding Manual Mode

Manual Mode is for users that want complete control over their weld settings. Manual Mode comes with 16 pre-loaded common weld programs that can be over written by the user and can be reset in the global settings if necessary (Figure 5.7).

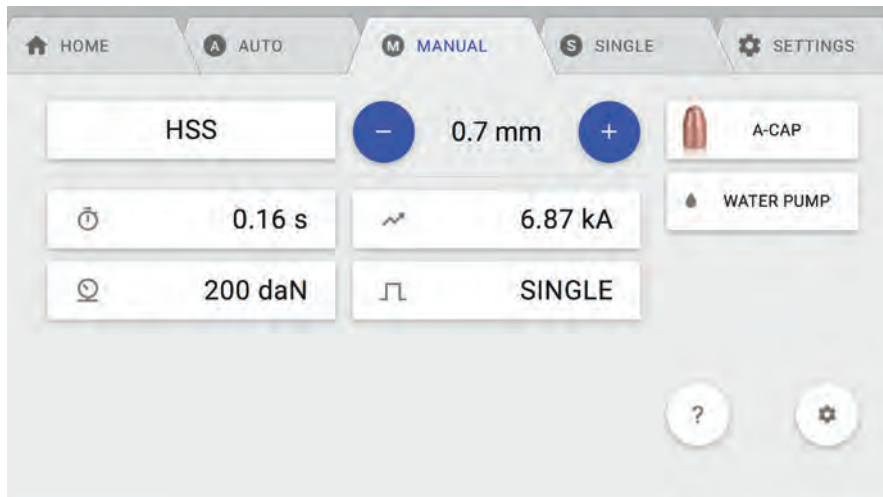

Figure 5.7

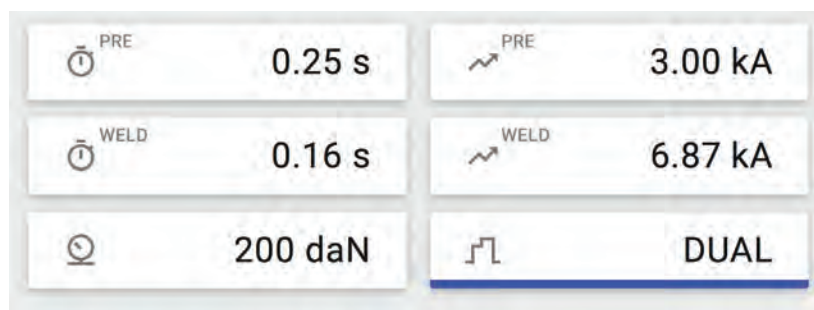

Figure 5.8

Available settings depend on which weld type is selected (Figure 5.8).

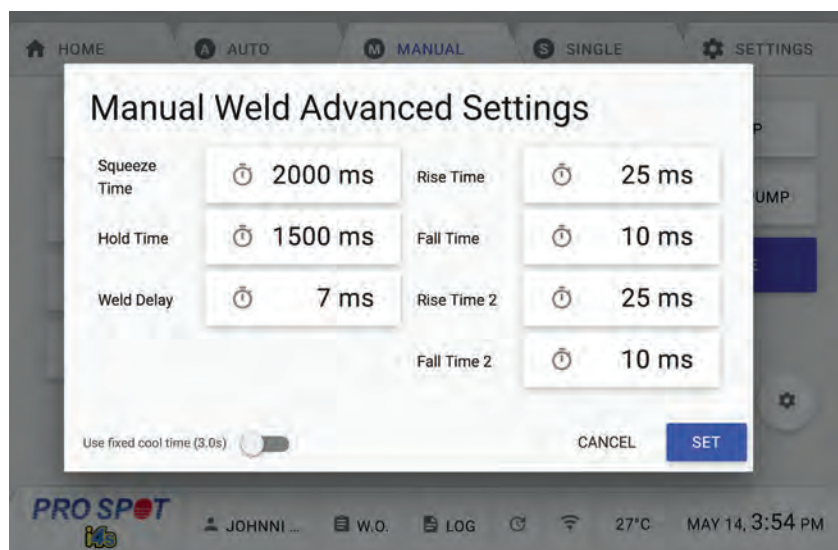

Figure 5.9

To change Advanced Settings touch the Settings Button in the lower right-hand side of the screen. A Manual Weld Advanced Settings Menu will pop with more settings (Figure 5.9).

5.6 Manual Mode Welding: Dual Weld Settings

When you change the Weld Type from Single to Dual, there are additional parameters available to adjust the weld as shown below.

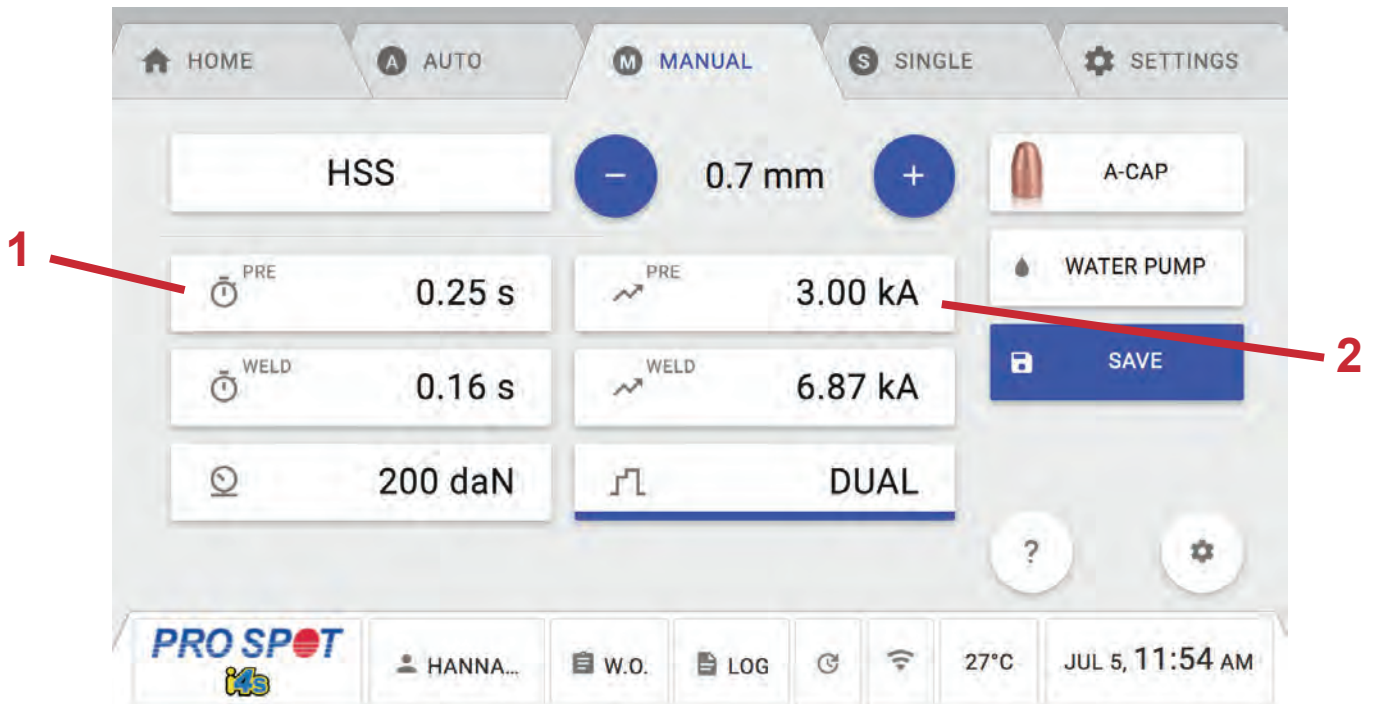

Figure 5.10

1. Preheat Time - This button allows the user to adjust the amount of time the welder applies the Preheat Current.

2. Preheat Current - This button allows the user to adjust the Preheat Current which is applied before the Weld Current in a Dual Weld. This precurrent is used to burn any non-conductive material away before applying the full Weld Current.

Using the example above, below describes what the welder would do:

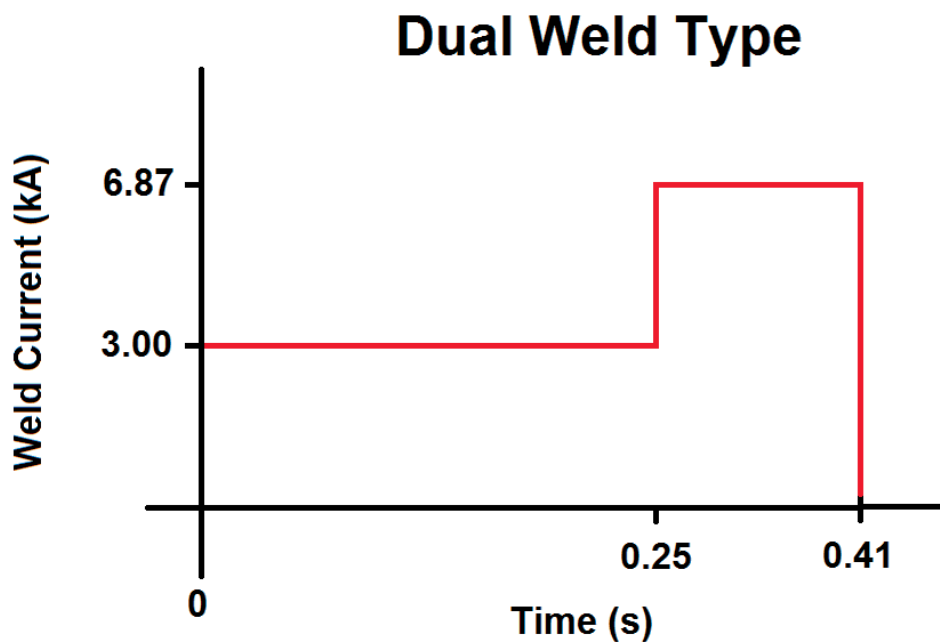

Figure 5.11

5.7 Manual Mode Welding: Pulse Weld Settings

When you change the Weld Type from Dual to Pulse, there are additional parameters available to adjust the weld as shown below.

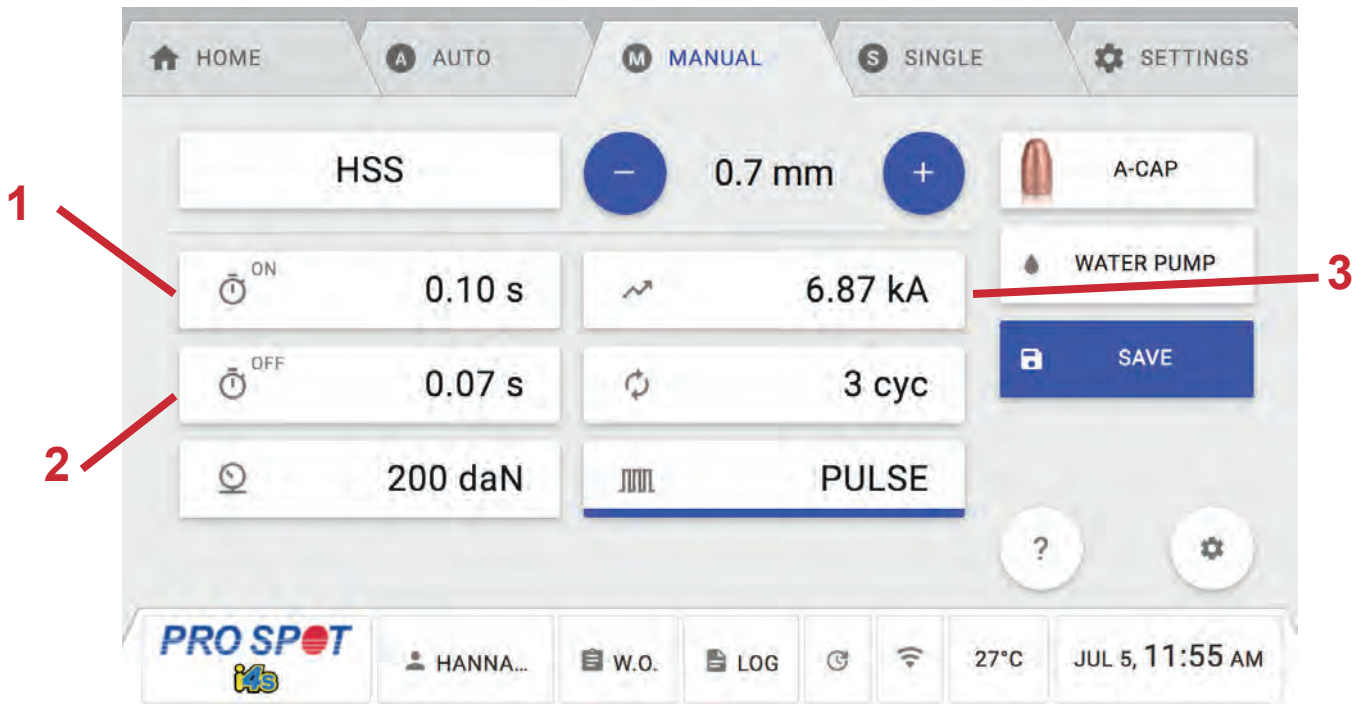

Figure 5.12

1. On Time - This button allows the user to adjust the amount of time the Weld Current is applied during each pulse repetition.
2. Off Time - This button allows the user to adjust the amount of time the Weld Current drops to a low level during each pulse repetition.
3. Pulse Count - This button allows the user to adjust the number of repetitions for the whole weld cycle.

Using the example above, below describes what the welder would do:

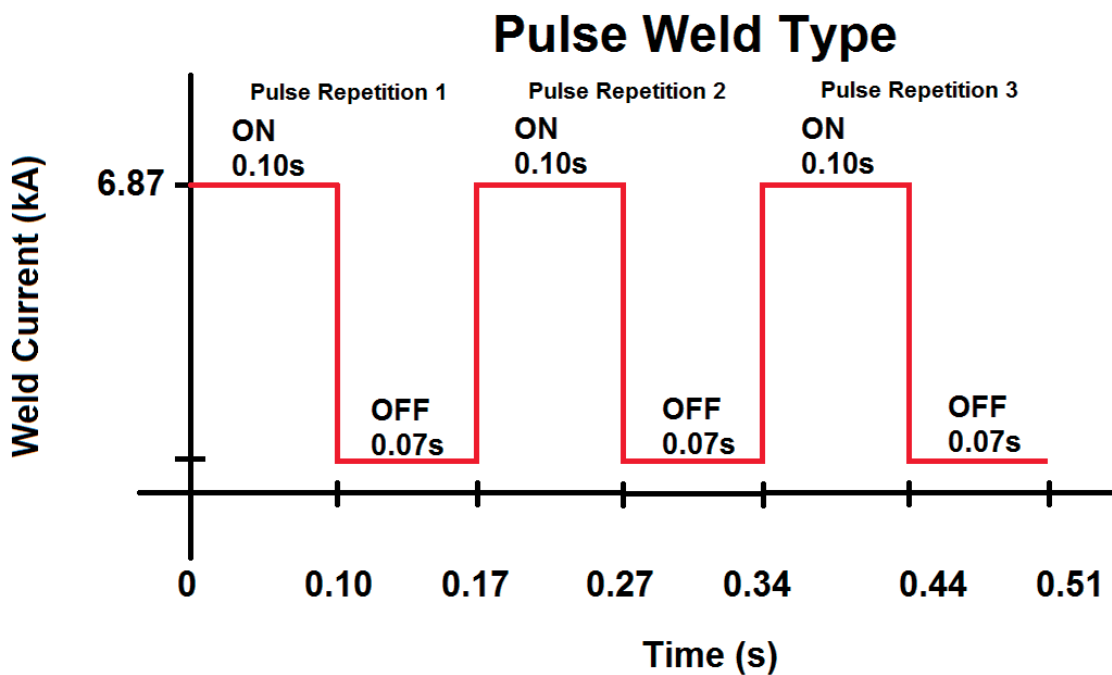

Figure 5.13

5.8 Creating a Custom Weld

How To Create A Custom Weld:

1. From the Weld Material screen, select Custom. Weld Material button gives several different options for pre sets including an option called Custom which is used to store user presets. Start by selecting Custom for Weld Material.

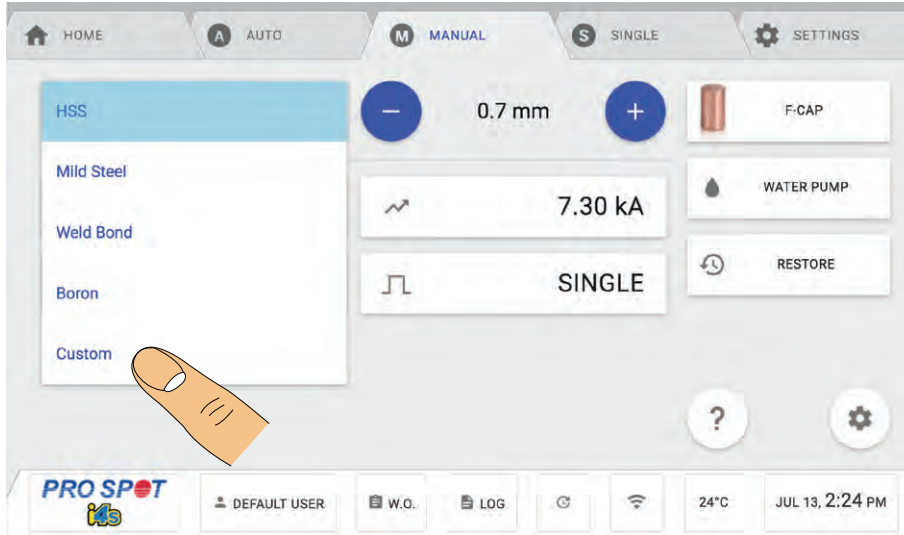

Figure 5.14

2. Select the the appropriate weld cap by pressing the Weld Cap Button (Figure 15).



Figure 5.15

3. Select one of the 3 weld types in the Main Manual Mode Screen:

- Single Weld: A single weld.
- Dual Weld: Two consecutive current pulses.
- Pulse Weld: 3-9 consecutive current pulses.

Save new selection to overwrite the current program (Figure 5.17).



Figure 5.16

4. Choose The Settings.

Set the desired parameters by selecting each one to be edited and modified using the open keypad.

If you selected Single Weld, you will see the following options:



How much current is applied during the weld.



Amount of time current is applied during the weld.



How much pressure is applied during the weld.

If you selected Dual Weld, you will see the following options:



Amount of time applied to the first pulse



How much current is applied to the first pulse



How much pressure is applied to the weld.



Amount of time applied to the second pulse.



How much current is applied to the second pulse.

If you selected Pulse Weld, you will see the following options:



Amount of time each pulse is applied.



How much current is applied during each pulse during the weld.



How much pressure is applied to the weld.



Amount of time between each pulse.



Number of pulses that are applied (between 3 and 9).

6.0 Single Sided Welding

Single Sided (SS) Mode can be used for many different applications in auto repair, such as rust and dent repair. With the i4s, you're able to access 16 programs associated with each selectable SS weld adapter.

6.1 Single Sided Weld Menu Guide

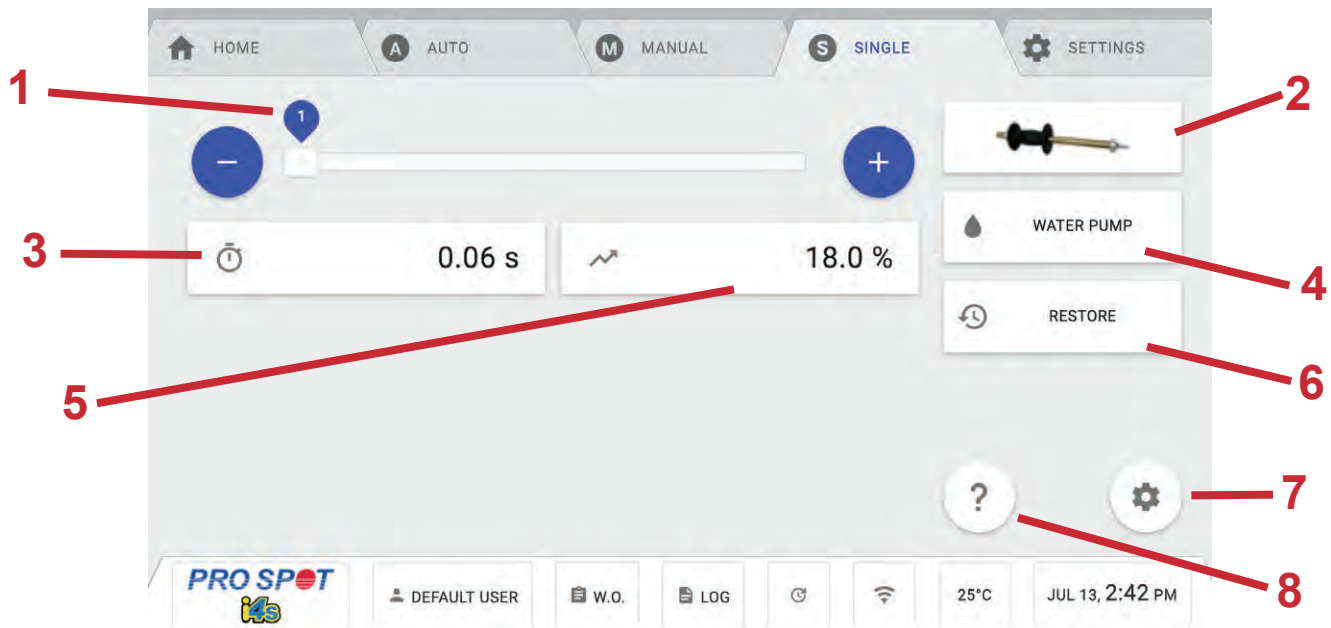

Figure 6.1

1. Program Number - This number indicates the program number for the chosen single sided adapter. Press the + and - buttons to increase or decrease the program number. Program number 1 is lowest setting and program 16 is the highest setting. It is best to start low and work your way up in power. The user can edit and overwrite a program by changing the Weld Time and Weld Power and pressing the Save button.

2. Single Sided Adapter Menu- This button provides selection between 11 different attachments: Slide Hammer, Pro Pull (optional), Single Sided, Carbon Shrink, Contact Shrink, Stitch Weld, Nail Weld, Rivet Weld, Bolt Weld, Nut Weld, and Washer Weld. Read more about each application in the sections below.

3. Weld Time - This button allows the user to change the weld time anywhere between 0.1 and 1 second.

4. Water Pump Shutoff - This button allows the user to temporarily disable the water pump so that an arm or weld caps can be changed on the PS-700W weld gun. The screen will prompt a countdown for you to wait, after it expires, you can make your necessary changes to the Weld Gun. After the change is complete, you can press DONE to continue and the water pump will turn back on.

5. Weld Power - This button allows the user to change the weld power anywhere between 5 and 50%.

6. Single Sided Advanced Settings - This button allows the user to change Trigger Delay, Rise Time, and Fall Time. The user will need the admin password in order to access this setting.

Trigger Delay: The amount of time between when the weld trigger is pressed and held and when the weld current is provided.

Rise Time: The amount of time it takes for the welder to reach full current.

Fall Time: The amount of time it takes for the welder to fall down from full current to 0.

7. Single Sided Weld Help - This button shows the user help information that applies to the Single Sided Weld screen.

6.2 Welding in Single Sided Mode

1. Select the desired adapter and program from the Single Sided Adapter Menu (Figure 6.2).

NOTE: Each attachment has a preset Program including Weld Time and Weld Power. These can be adjusted by selecting either the Weld Time button or the Weld Power button and inputting the desired amount.

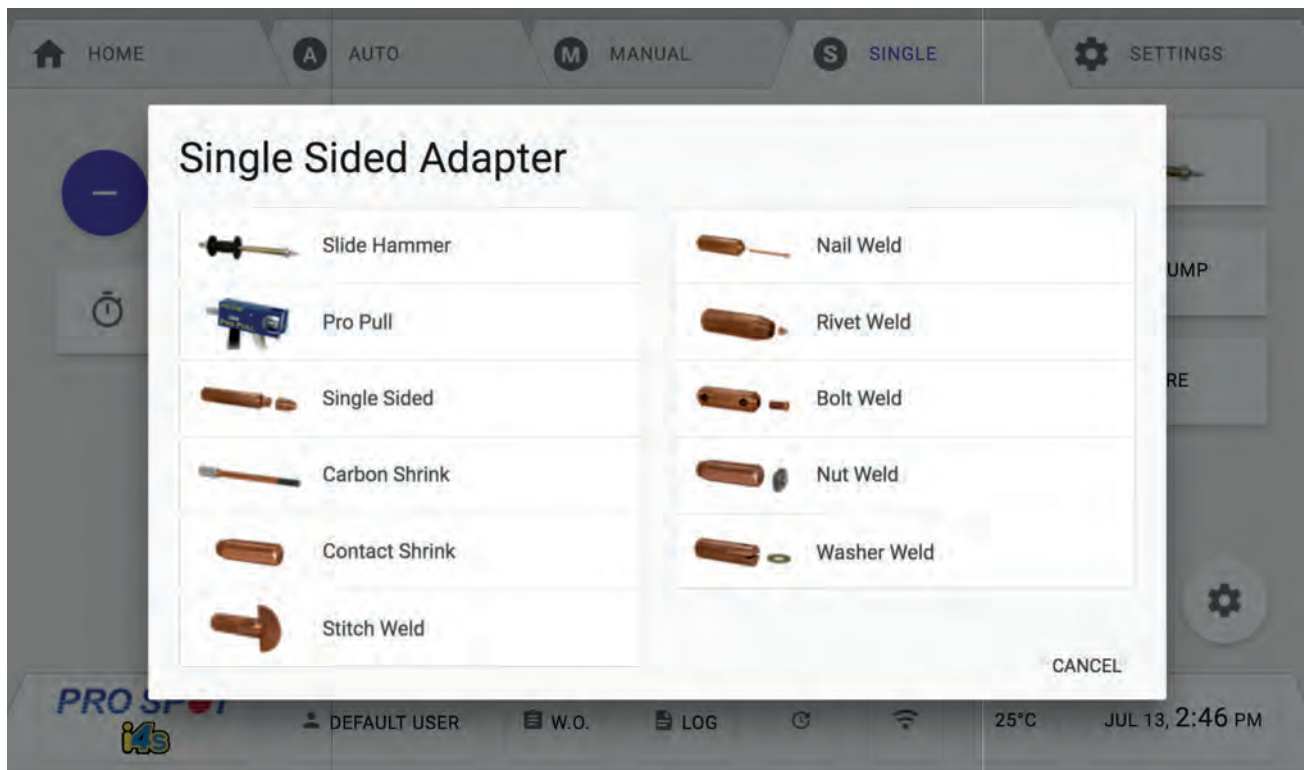

Figure 6.2

7.0 i4s Weld Gun

Double-Acting Spot Gun (Part #: PS-700W)

The spot gun is used for Double Sided Welding programs: HSS Galvanized Steel, Mild Steel, Weld Bonding, Boron Steel, Pulse Welding, OEM Required Programs and Custom Programs.

Double-Acting Spot Gun Component Diagram

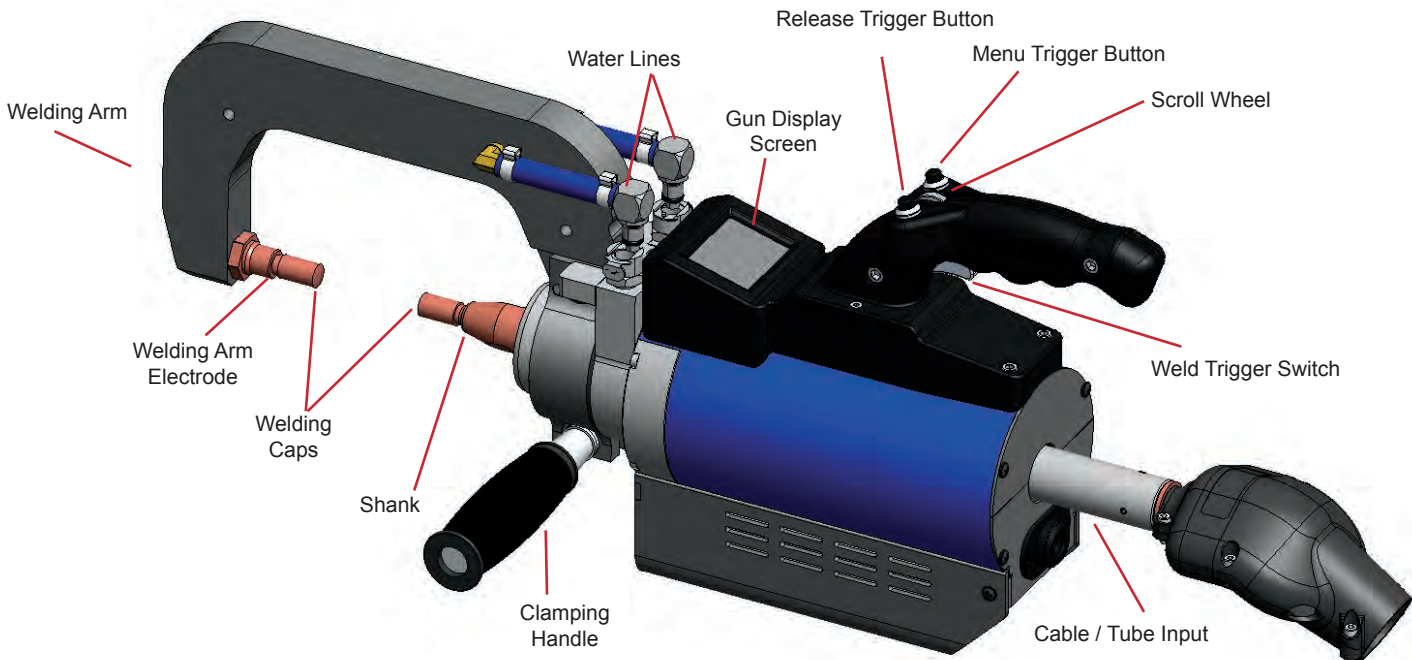

Figure 7.1

Using the Double-Acting Gun:

1. Select the program you wish to weld in and calibrate if needed.
2. Bring the weld gun to the material you wish to weld or test on.
3. Press the Release Trigger Button to open the electrodes.
4. Press and hold both, the Weld Trigger AND top right (Menu Trigger) Button to weld.

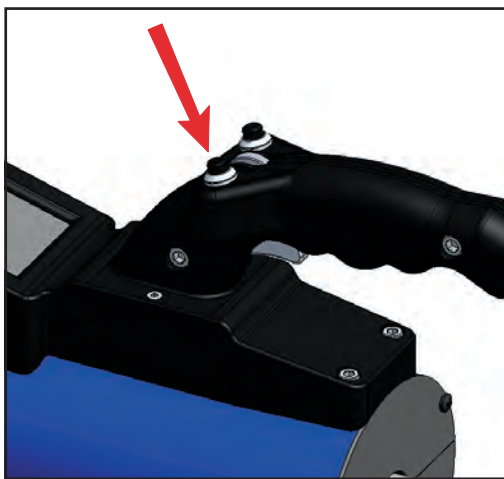

Figure 7.2

Press and hold the Release Trigger Button to open electrodes wide.

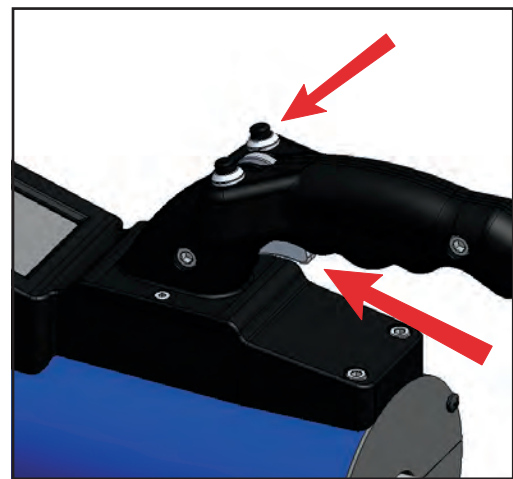

Figure 7.3

Press and hold BOTH, the Weld Trigger AND top right (Menu Trigger) button on the gun to close electrodes and weld.

7.1 i4s On-Gun Screen & Gun Controls

The i4s gun has an on-gun screen that can show the user exactly which settings and what kind of welds they are producing. This feature gives users the options to make changes to weld settings directly from the gun without needing to go back to the machine.

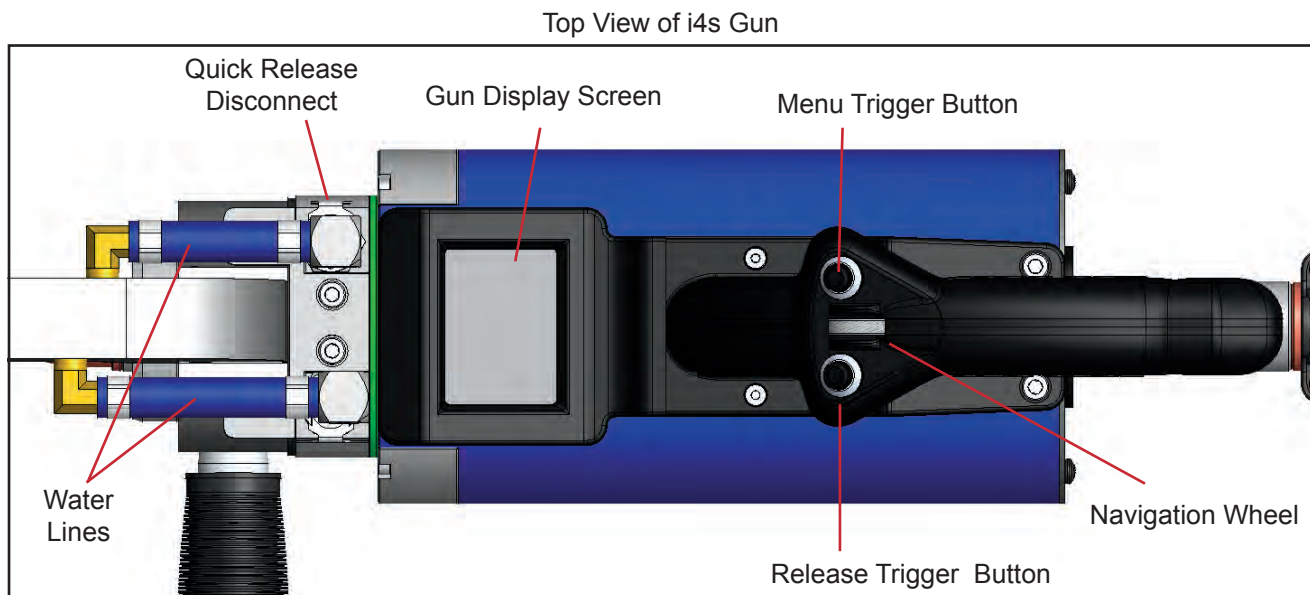

Figure 7.3

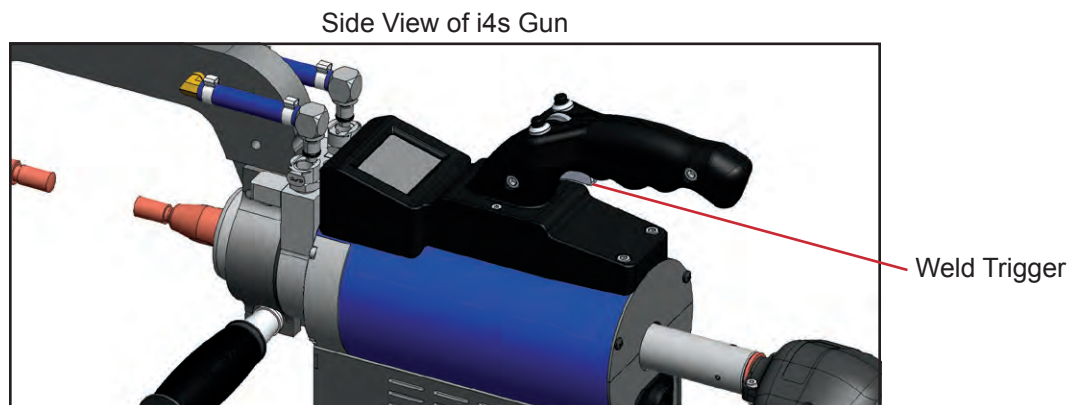

Figure 7.4

i4s Gun Controls

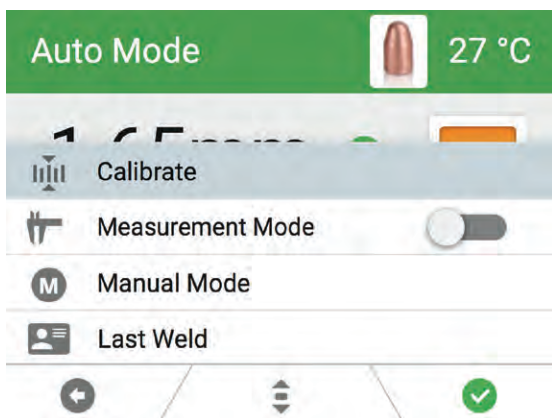

Figure 7.5

The fingertip controls allow the user to calibrate, easily navigate between programs, turn on Measurement Mode and check the results of the last weld.

To access the Options Menu from the gun:

1. You must be in Auto or Manual Mode.
2. Press and hold down the Menu Trigger Button on the gun. Use the scroll wheel to pick your selection. To go back, press the Release Trigger Button.

NOTE: A guide at the bottom of the on-gun screen shows icons indicating the functionality of each button when in the Options Menu.

i4s Gun Screen Displays

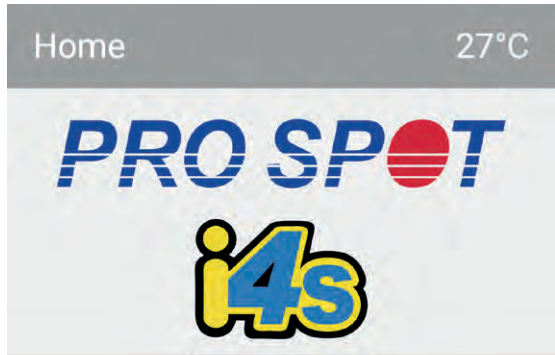

Home Screen
Figure 7.6

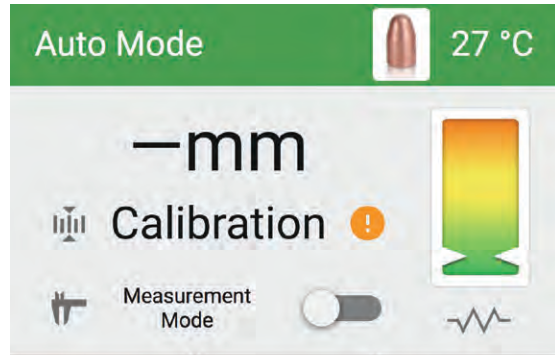

Auto Mode Screen
Figure 7.7

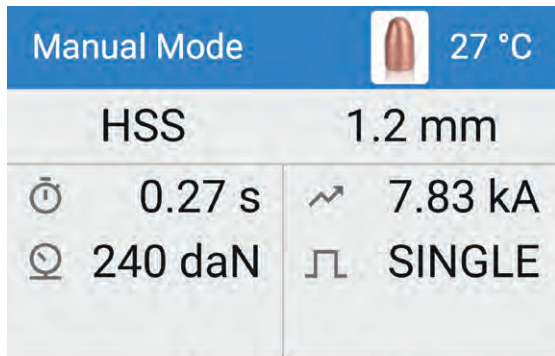

Manual Mode Screen
Figure 7.8

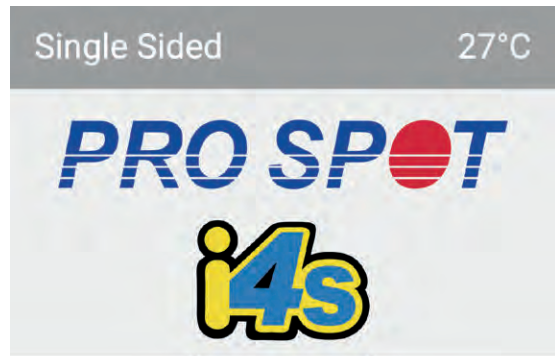

Single Sided Mode Screen
Figure 7.9

i4s Gun Weld Feedback Screen

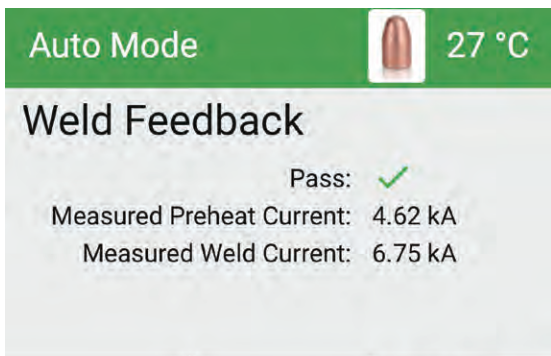

Weld Feedback Screen
Figure 7.10

The Weld Feedback screen will show up on the i4s screen and the i4s gun screen after a weld has been performed. The Weld Feedback screen indicates to the user if the weld passed or failed. It also displays the Measured Preheat Current and the Measured Weld Current.

7.2 Extension Arms

The i4s has a variety of extension arms to accommodate most welding applications.



NOTE: Extension arms marked “optional” are available through your local distributor or online at www.prospot.com.

REMARQUE: Bras d’extension portant la mention «facultatif» sont disponibles à partir de votre Distributeur régional ou en ligne à www.prospot.com

i4s Extension Arms



PSW-WH-090
Wheelhouse Arm



PSW-WH-090
Wheelhouse Arm



PSW-CXS1
C-X Arm



PSW-320
320 Extension Arm



PSW-520
520mm Extension Arm

Changing Extension Arms

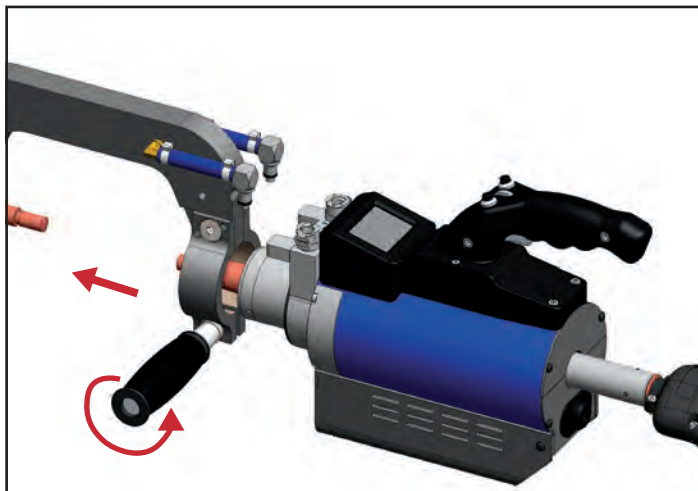
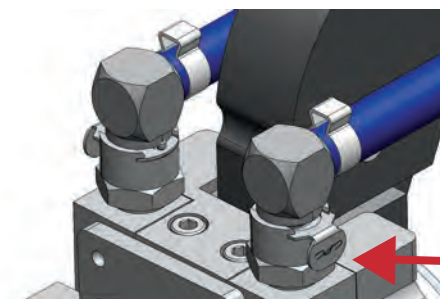

Figure 7.11

How To Change Extension Arms:

1. Make sure the Water Pump is off.
2. Disconnect water lines by pressing release button.
3. Loosen the extension arm handle.
4. Slide the extension arm off.
5. Replace with the arm you wish to weld with by sliding it on.
6. Reconnect water lines.
7. Tighten the handle to secure the welding arm..
8. Check electrode alignment.



To remove the water lines: Press the release button on each line.

Figure 7.12



Turn off the water pump before disconnecting water lines.
Make sure to properly secure all water hoses before welding.

7.3 Electrode Components



IMPORTANT! Using incorrect welding electrodes with extension arms may result in weak welds and/or damage to your welder.
IMPORTANT! En utilisant des électrodes de soudage inexactes au bras d'extension peut donner des soudures faibles et / ou endommager votre soudeur.

PSW-080 SHANK/CAP COMPONENTS



1



2



3



4

1. Divider - P/N 90-1711
2. O-ring - P/N 52-0086
3. Screw-in Shank - P/N 90-1710
4. Weld Cap - P/N PS-023

PSW-520 SHANK/CAP COMPONENTS



1



2



3



4

1. Divider - P/N 90-1726
2. O-ring - P/N 52-0086
3. Screw-in Shank - P/N 90-1717
4. Weld Cap - P/N PS-023

PSW-WH-090 SHANK/CAP COMPONENTS



1



2



3



4



5

1. Divider - P/N 90-1711
2. O-ring - P/N 52-0086
3. Screw-in Shank - P/N 90-1723
4. Weld Washer - P/N PS-1135
5. Cap Screw, M6 x 16 - P/N S-103

8.0 Electrode Alignment, Removal & Maintenance

The machine must always have the electrodes aligned. Improper alignment of the electrodes can lead to poor welds that will not pass OEM requirements.

To adjust the electrode on the machine, use the set screws to set alignment (Figure 1). Use an Allen Wrench to make slight adjustments to the set screws. Ex: to move electrode down, loosen screw (C) and tighten screws (A and B).

Use an extension arm to test the alignment. Once the electrode in the gun is evenly aligned with the extension arm electrode, tighten down the arm and recalibrate the weld gun.

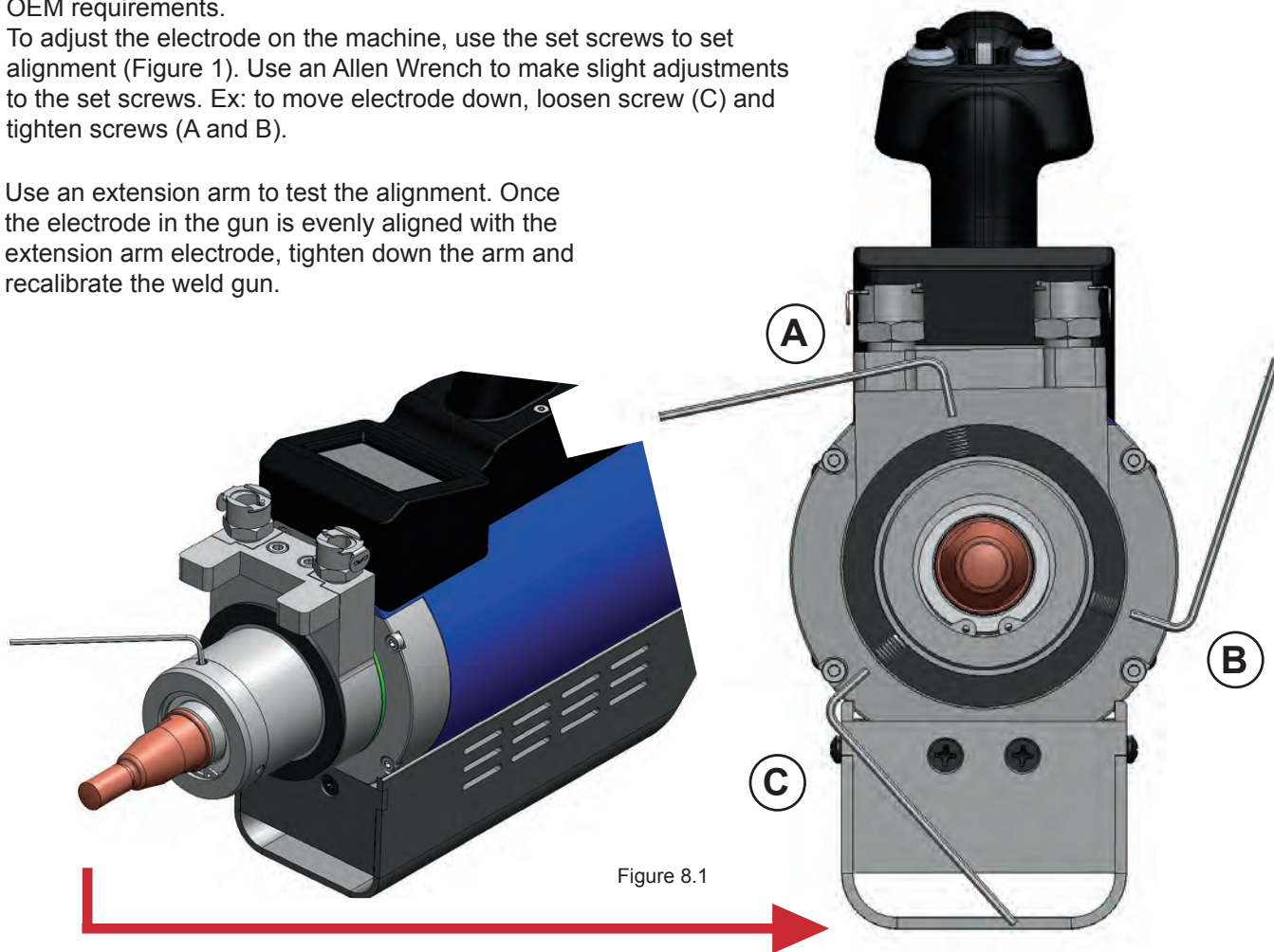

Once you have the electrode alignment correct, it should look like the image below on the left (Figure 8.2). If it is not a straight alignment, like the image below on the right (Figure 8.3), it will lead to poor and weak welds.

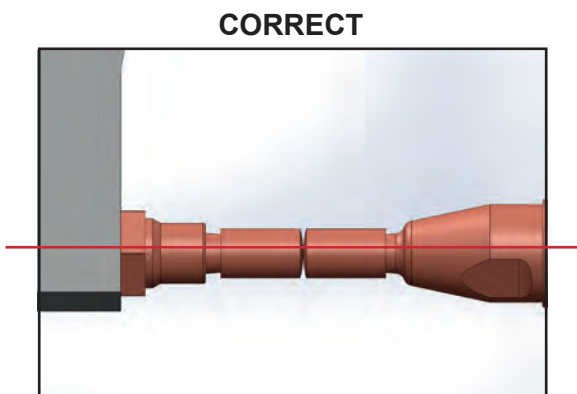

Figure 8.2

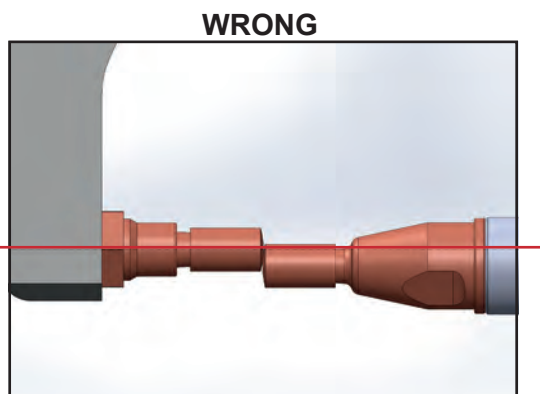

Figure 8.3



IMPORTANT! Proper electrode alignment is critical to weld integrity.

IMPORTANT! Toujours maintenir l'alignement des électrodes appropriées. Ne pas le faire peut conduire aux soudures faibles de qualité inférieure!

8.1 Removing Welding Electrodes

Removing Extension Arm Electrode and Weld Cap



1. Attach vice grips to the weld cap and electrode being removed. Grip the handles and twist them in opposite directions.



2. If twisting the cap and electrode doesn't work, you can gently tap them with a hammer (Pro Spot ALU-9 Aluminum Hammer shown) while maintaining control of the electrode by holding one of the vice grips firmly with one hand.



3. Carefully remove the electrode and allow the excess water to drain from it. You can now release the vice grips from the electrode and weld cap. If you want to, you can continue on to the following step with the vice grip still attached to the electrode shaft for a better grip.



4. Finally, if the weld cap has not loosened, hold on to the electrode and gently tap the weld cap off with a hammer. Make sure that when you are tapping at the weld cap, to aim your hammer outward, not just down, and away from the electrode. Rotate the electrode to loosen the cap on all sides.



IMPORTANT! Do not attempt to remove the electrode by hitting it. This could damage the electrode and/or the spot gun.

IMPORTANT! N'essayez pas de retirer l'électrode en la frappant. Cela pourrait endommager l'électrode et le "pistolet".

8.2 Welding Electrode Maintenance

In order to maintain structurally-sound welds, it is important to keep your welding electrodes and weld caps from forming any build-up. It is also important to maintain a 6mm weld nugget diameter. Clean electrodes with a file or Tip Sharpener (Electrode Dresser) and periodically replace weld caps.



WARNING! The electrodes may be hot. Use caution when handling them.

ATTENTION! Les électrodes peuvent être chauds. Soyez prudent lors de leur manipulation.

PLT-51 Tip Sharpener

Note: The PLT-51 (meant for the OEM weld caps) is distinguishable from the PLT-50 by the lack of green mark on the neck of the grinding head.



Cap cleaning:

1. Turn off the i4s.
2. Connect the PLT-51 Tip Sharpener to a compressed air hose.
3. Set the sharpening blade on the weld cap to be cleaned.
4. Hold down the paddle switch while applying a slight pressure against the weld cap for about 10-15 seconds.
5. Repeat these steps 3 and 4 until all debris is cleared from the weld cap and there is a clear connection path between both tips.



A video demo of the PLT-51 in action can be found on our YouTube Channel at: <https://youtu.be/yx0efiLb8IE>



Pro Spot International, Inc.
5932 Sea Otter Place
Carlsbad, CA 92010

Toll Free (US Only): (877) PRO SPOT
Phone: (760) 407-1414
Fax: (760) 407-1421

E-mail: info@prospot.com
Web: www.prospot.com