

Instruction Manual

MNL-PR-5D-v1.1





About Pro Spot

Pro Spot International specializes in quality welding and repair products for the collision repair industry. Pro Spot owns numerous patents for special welding equipment and applications, and works with the largest auto manufacturers in the world. Pro Spot is a proud 'MADE IN THE USA' manufacturer in Carlsbad, CA. The turnkey facility includes Design, Engineering, Machine and Sheet Metal Shops, Powder Coating, Assembly, Training and Customer Support. The Pro Spot equipment line includes resistance spot welders, aluminum & steel dent repair systems, pulse MIG welders, rivet guns and tools, dust-free sanding systems, fume extraction and more.

Pro Spot Training and Services

Pro Spot provides on-going training to all of our distributors and their technicians, therefore, all owners of Pro Spot products receive complete training first hand. Pro Spot has two ASE certified training programs that are I-CAR Alliance approved. Pro Spot has a fully equipped training facility at their Headquarters in Carlsbad, CA, as well as in Nashville, TN, and Denver, CO, for groups to come in and train on all products. To stay up-to-date, Pro Spot offers their unique My.prospot.com which includes interactive training courses for shops and technicians to access online.

Pro Spot is constantly striving to improve. Whether that means designing innovative equipment, implementing cutting edge technical support or further improving their already extensive training programs, Pro Spot is always looking for ways to better our customer's experiences.



PRO SPOT

QUALITY WELDING SYSTEMS

Pro Spot International, Inc.
5932 Sea Otter Place
Carlsbad, CA 92010

Toll Free: (877) PRO SPOT
Phone: (760) 407-1414
Fax: (760) 407-1421

E-mail: info@prospot.com
Web: www.prospot.com

TABLE OF CONTENTS

1.0 SAFETY	3
1.1 Work Environment	3
1.2 Electrical Safety	3
1.3 Personal Safety	3
2.0 TECHNICAL	4
2.1 Technical Specifications	4
2.2 Additional Arms and Options	4
2.3 Product Identification	4
2.4 Functionality	5
3.0 BEFORE USING THE DEVICE	6
3.1 Battery Charging	6
3.2 Device Operation	6
3.3 Riveting Arms	7
4.0 MODULAR C-ARM ATTACH & REMOVE	8
4.1 Digital Display Settings	7
5.0 APPLICATION OF THE DIE SETS	10
5.1 Die Application	11
5.2 Rivet Installation	12
5.3 Rivet Removal	13
5.4 Sheet Flattening Procedure	14
5.5 Calibration Hole Procedure	15
5.6 Flow Form Installation Procedure	16
6.0 MAINTENANCE AND REPAIR	17
7.0 NOTES	18

1.1 Work Environment



WARNING! Do not operate or place the riveter near water, in wet locations or outdoors. Risk for injuries or damage to the riveter.

WARNING! Do not place the riveter on unstable or uneven surface. The riveter might fall causing personal injuries or damage to the riveter.

- Keep the work place clean and free of debris to prevent accidents.
- Keep this device away from children and unauthorized or untrained personnel.
- Store this device in a clean environment. Keep away from high temperatures, corrosive liquids and gases that could damage the equipment.
- Never use or charge this device in an environment with flammable and explosive liquid, gas or dust.

1.2 Electrical Safety



WARNING! All electrical connections must be made by a qualified electrician. Risk for electrical shock.

- Always match the charger plug with the wall socket. Never modify the plug.
- The riveter and all of its components should never be exposed to wet or extremely humid environments. Exposing any part of the electrical system to water will increase the risk of electrical shock.
- Always unplug the charger during a lightning storm.
- Never burn or short circuit the battery. Always dispose of batteries properly.

1.3 Personal Safety



WARNING! Make sure to use safety goggles when using the riveter.



WARNING! The riveter may only be used by qualified personnel. The user of the riveter must have knowledge of riveting and of alignment of collision-damaged vehicles.

- Keep focused and alert while operating the device. Never use it when you are tired or under the influence of medication or alcohol.
- Wear slip-proof gloves and safety glasses while operating the device.
- Never put your fingers between installed dies. Serious injury may occur.

Thank you for choosing Pro Spot's PR-5D Cordless Rivet System. This device utilizes a high quality lithium-ion battery to power the micro-programmed control unit (MCU), and the ultra-high hydraulic pressure system. The PR-5D is simple to learn, easy to use, safe and very efficient.

2.1 Technical Specifications:

- Force Range:** 10kN to 50kN, set digitally with 1kN resolution.
- Travel Range:** 43mm.
- Power:** Electro-Hydraulic Actuator.
- Voltage:** 18V Li-ion Battery Powered.
- Charging Source:** AC 100V~240V 50-60Hz (Auto-Switching).
- Charging Time:** Approximately 2 Hours.
- Working Temperature:** 14- 140°F (-10~40°C).
- Riveting Time:** 3-5 seconds.
- Continuous Usage:** Approximately 250 cycles.
- Operation Noise level:** 60-70dB.
- Tool Weight:** 9.9 lbs (4.5 kg) with Standard 55mm Arm and Battery installed.
- Includes:** Standard C-Arm, (2) Rechargeable Batteries, Battery Charger and Punch & Die Sets.
- Cycles Per Charge:** 200 Cycles (Varies by usage / force strength).
- Replacement Battery:** Makita part # BL1830.

Unique Features

- Ability to set force digitally
- Data logging of rivet force, number of cycles
- Alarms can be set for service level
- Data can be transferred via Bluetooth



2.2 Additional Arms, Dies and options

Additional Arms, Dies and options are available. Please contact your local suppliers.

2.3 Product Identification

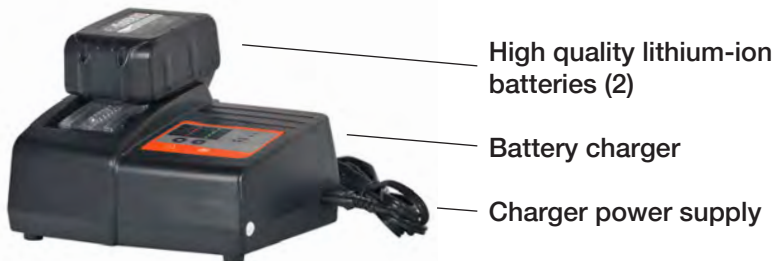
- 1 Stationary Side/Die
- 2 Driven Side/Die
- 3 C-Arm
- 4 Tool Balancer Loop
- 5 Pressure Adjustment Buttons
- 6 Warning Light
- 7 Work Light
- 8 Trigger Switch
- 9 Handle
- 10 Manual Retract Button
- 11 Lithium-ion Battery
- 12 Locking Nut

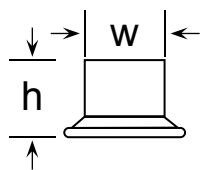

<p>Rivet Size Guide</p> 	<p>PR-SPR-56 Self-Piercing Rivet</p>  <p>5mm(w) x 6mm(h)</p>	<p>PR-SPR-58 Self-Piercing Rivet</p>  <p>5mm(w) x 8mm(h)</p>	<p>PR-SPR-510 Self-Piercing Rivet</p>  <p>5mm(w) x 10mm(h)</p>
--	---	--	---

APPLICATIONS DIES



REMOVAL DIES

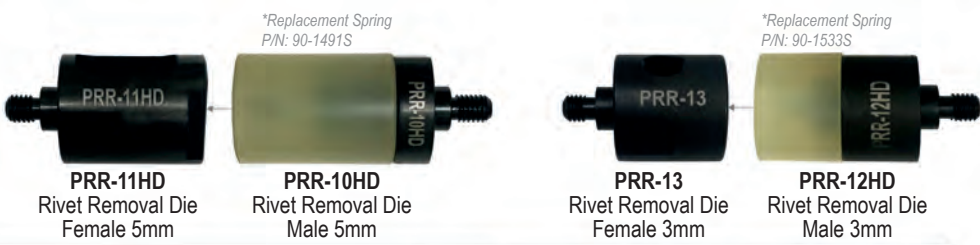

STANDARD DIE KIT

The standard die kit included with the PR-5D is collection of versatile dies that lend themselves to multiple applications. Changing dies is as easy as turning a screw.



2.4 Functionality

- Electro-hydraulic operation, portable and easy to operate.
- Different sized arms are available for various applications.
- Arms rotate 360° for use at various angles.
- The output pressure can be adjusted for different repair applications.
- Micro-computer control system - Pressure is monitored automatically and has a double safeguard function, automatically retracting after the rivet has been compressed.
- Manual Reset - Operation can be stopped by releasing the gun trigger. Pressing the manual retract button will automatically retract to the original position.

Before using the PR-5D Cordless Rivet System, perform a visual check of the charger, the batteries, and the entire rivet gun along with the arms, punches, and dies. This visual inspection should be done before each use. Verify that the connection for the battery is good. Check all components carefully in order to guarantee safety.

3.1 Battery Charging

- The rivet gun will beep three times and flash the LED three times when the battery reaches a low voltage threshold. Low voltage condition is approximately 16.7 Volts.
- Each battery can be charged approximately 600 times. After 600 charges, the battery will need to be replaced. When you notice the life of each battery charged gets shorter, this is a good indication that the battery needs replacement. Do not discharge the battery completely, it will damage the battery.
- If the rivet gun will not be used for a long period of time, the battery should be removed. Every couple of months, the batteries should be fully charged without interruption. If the rivet gun will not be used for extended periods of time, the batteries should be charged to 80% at the time of storage.
- Do not burn a battery in any situation, possible explosion and personal injury may occur.
- The PR-5D Cordless Rivet System and all of its components should never be exposed to rain or extremely humid environments. Exposing any part of the electrical system will increase the risk of electrical shock.
- Do not disassemble the rivet gun, the batteries, or the charger. If any issues occur during usage, you should contact your distributor or Pro Spot Headquarters for authorized repairs.

3.2 Device Operation

- Check if there are any visible breaks, missing components, adjustment issues or any other issues which will cause a safety problem or prevent operation. Any issues found must be resolved before the riveter is to be used.
- The stop screws in the arm are used to prevent the arm from being removed during operation. Verify that the stop screws are tight before use. The stop screws should only be removed when changing to a different sized arm.
- The rivet gun should be free of grease and dirt, especially on the handle and trigger to prevent it from slipping out of your hand during use.
- When changing dies, remove battery to prevent pinching.

Extension Dies

When using the PRR-CQ-240-120 ARM, the best choice of Extension Die is the PRR-EXT-65. This places the mating point for the die contact at the Center Line of the arm gap. The lowest angular deviation will occur at this position.

- The ram pressure is set from the factory (50kN), but can be adjusted up or down if required.
- Be sure that the proper length rivet has been used for the thickness stack.
- If the self piercing rivet does not sit flush with the panel, pressure needs to be increased. Refer to section 4.0, Setting Force/Pressure.

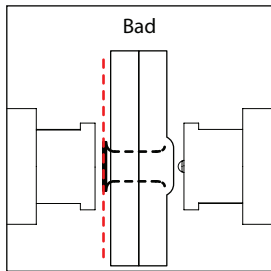
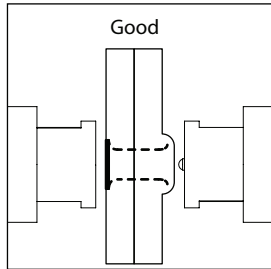

Press Button
to Decrease
Pressure

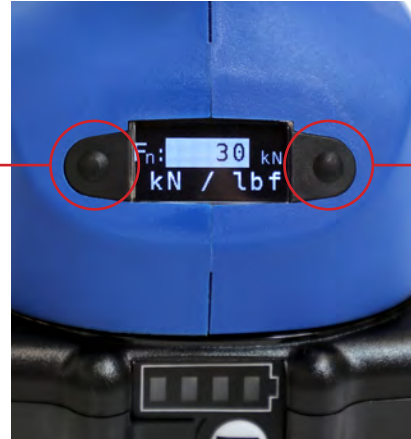

Press Button
to Increase
Pressure

3.3 Riveting Arms:

- Quick change design allows arms to be changed in seconds.
- Removable handle can be used on the left or right side.
- Self-Centering feature keeps ram inline.
- 360° pivot action around the nose.



PRR-CQ-55-85
(Standard)



PRR-CQ-120-80
(Optional)





PRR-CQ-240-120
(Optional)

The PR-5D features a modular C-Arm and accessory quick change system. To switch between various arm sizes and other optional accessories, remove the lock nut and swap out arm as shown in diagram below.

- Slide desired arm onto **arm adapter** against **o-ring**.
- Thread the **lock nut** onto arm adapter finger tight.
- **Arm** is now secure.
- Reverse steps to remove arm.

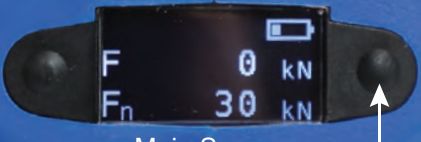
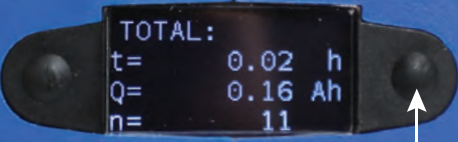

MENU SCREEN	RIVETER FUNCTION
	<p>Start-up screen. Press gun trigger once to turn riveter on. Battery must be installed.</p>
	<p>Main Screen - MUST be in this screen to operate the gun:</p> <ul style="list-style-type: none"> • Battery Level. • F: Force being applied during pressure cycle. • Fn: Set Force.
SETTING FORCE/PRESSURE	
 <p>Hold Left and Right Buttons</p>	<p>PR-5D must be in the “Main Screen” to be able to access Force/Pressure adjustments.</p>
 <p>Hold Left and Right Buttons</p>	<p>Force Units Preference. Options for Units: kN - kilonewtons, lbf - pound force, bar - metric, psi - pounds per square inch. Use left and right buttons. Press Gun Trigger to save desired setting (returns to main screen).</p>
	<p>Force Setup. Range 10-50 kN. <i>Left Button:</i> Decreases Force. <i>Right Button:</i> Increases Force. Press Gun Trigger to save desired setting (returns to main screen).</p>
SELECTING USERS	
	<p>From Main Screen, press right button 3 times.</p>
 <p>Hold Left and Right Buttons</p>	<p>Hold left and right button, release buttons when Highlighted.</p>
	<p>Use Left and Right buttons to select desired user. Press gun trigger 2 times to get back to main screen.</p>

MENU SCREEN	RIVETER FUNCTION
 <p>Main Screen</p>	<p style="text-align: center;">SERVICE AND USAGE INFORMATION</p> <p>Press Right Button to access Cycle Count.</p>
	<p>Cycle Count:</p> <ul style="list-style-type: none"> • t: Total hours used. • Q: Total energy used. • N: Total cycles performed. <p>Press right button to access Service Information.</p>
	<p>Service Information:</p> <p>Number of Cycles. Number of days until service. Refer to manual for servicing requirements.</p>

5.0

APPLICATION OF THE DIE SETS



- This device includes 12 dies: PRR-10, PRR-11, PRR-12, PRR-13, PRR-14(2), PRR-15, PRR-16, PRR-17, SA-0400, SA-0401, SA-0402.
- **TIGHTEN THREADS FULLY OR DAMAGE TO DIE/PISTON RAM THREADS WILL OCCUR!** During use, the pressure must not be on the threads of the dies. They must be firmly seated or they could break during operation.
- Never operate the rivet gun without any material between the clamps. Operating the rivet gun without metal between the dies will cause damage to the punch and die. Do not operate or charge the rivet gun or batteries in a dust filled environment.
- Choose the correct punch and die set that OEM specifies.

5.1 Recommended Rivet/Die/Stack-up

The following table shows the recommended rivet and die combination for given joint stack-ups:

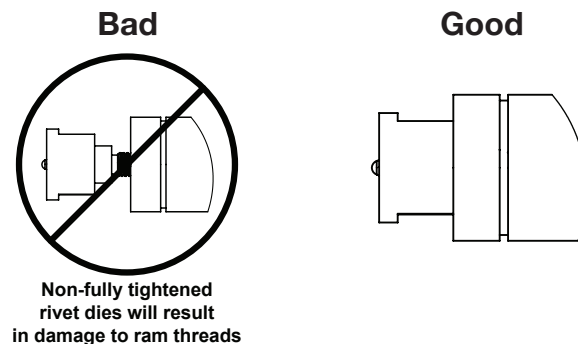

Removal Die - The new removal die provides more robust removal of longer rivets (10mm), eliminating jamming and breaking where the previous SPR rivet was located. Using this system, SPR rivets can be removed in a fraction of the time it would take to drill out.

Flow Form Rivets - The areas where you cannot fit an adjacent SPR or where repair procedures don't allow it, Flow Form Rivets are the answer. Becoming more popular in repair procedures, Flow Form uses a calibration punch which allows a Flow Form Rivet to be installed in the same location as the original joint, eliminating the time it would take to drill out.

APPLICATION PROCEDURES:

Installing Self-Piercing Rivets (SPR)

1. Align the removal dies in the center of SPR.
2. Complete pressure cycle so the male rivet die pushes the SPR through the base materials into the forming die.
3. Proceed to next rivet.

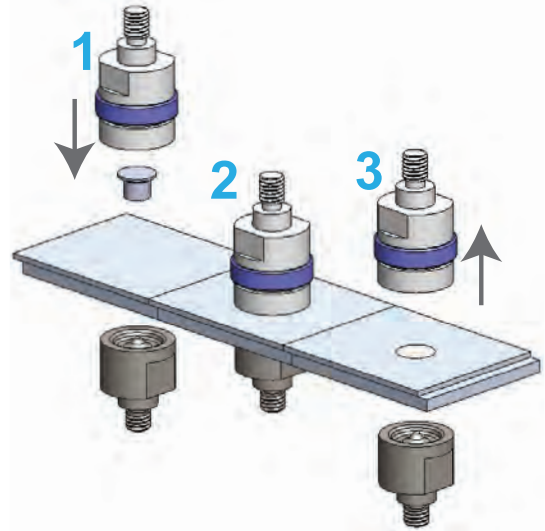

Final Application

Flow Form Rivets / Solid Rivets Process:

Rivet Removal

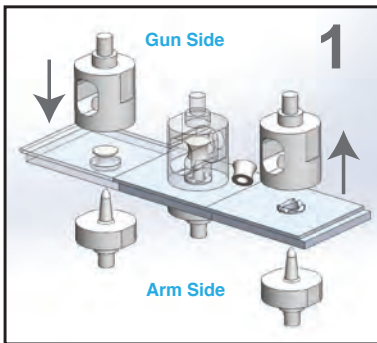

Removal

1. Align the removal dies in the center of SPR.
2. Complete pressure cycle so the male rivet die pushes the SPR into the receiving die.
3. The rivet is now extracted.

Flattening

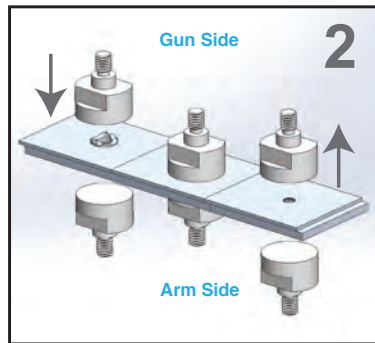

Flattening Procedure

1. Align the flattening dies in the center of hole.
2. Complete pressure cycle so the flattening dies compress the edges of the hole.
3. The area is now flattened.

Punch Calibration

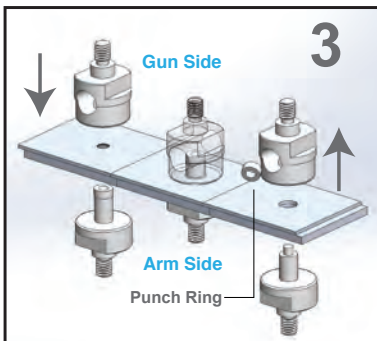

Punch Calibration Procedure

1. Align the calibration dies in the center of hole.
2. Complete pressure cycle to make exact hole size and collect the punch ring for reuse.
3. The hole is now ready for Flow Form rivet installation.

Rivet Installation

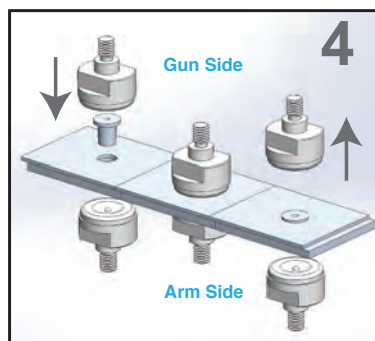

Installation of Flow Form rivets/ solid rivets

1. Align the dies in the center of rivet.
2. Complete pressure cycle so the Flow Form rivet is formed.
3. The installation of the Flow Form rivet is now completed.

Rivet Installation Procedure:

1. Make sure rivet gun ram is fully retracted. If it is not, press Manual Retraction Button (Shown in Section 2.3 item #10).
2. Install Rivet Holding die on Piston Side. **TIGHTEN THREADS FULLY TO AVOID DAMAGE TO THREADS.**
3. Install Matching Rivet Forming Die. See table above for recommended rivet/die/stack-up combination. **TIGHTEN THREADS FULLY TO AVOID DAMAGE TO THREADS.**
4. Insert rivet into rivet holding die. The magnet should hold the rivet securely, and the rivet head should fit snugly in cavity.
5. Bring gun arm assembly to the work piece joint to be riveted. Position in location. Squeeze rivet gun trigger to extend ram until rivet meets the sheet to join. Continue to hold trigger until riveting process is completed and ram retracts. Ram will retract automatically.

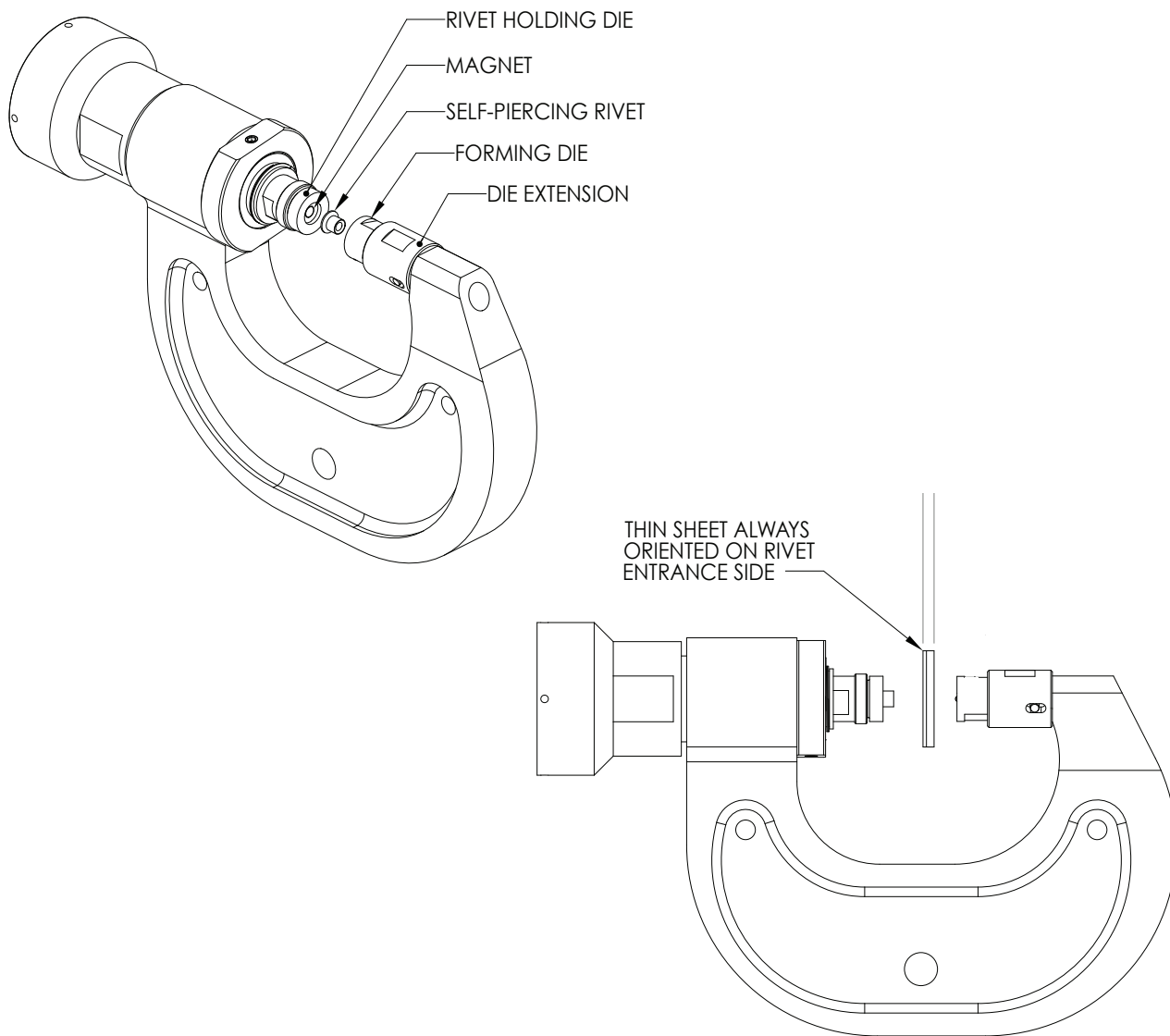

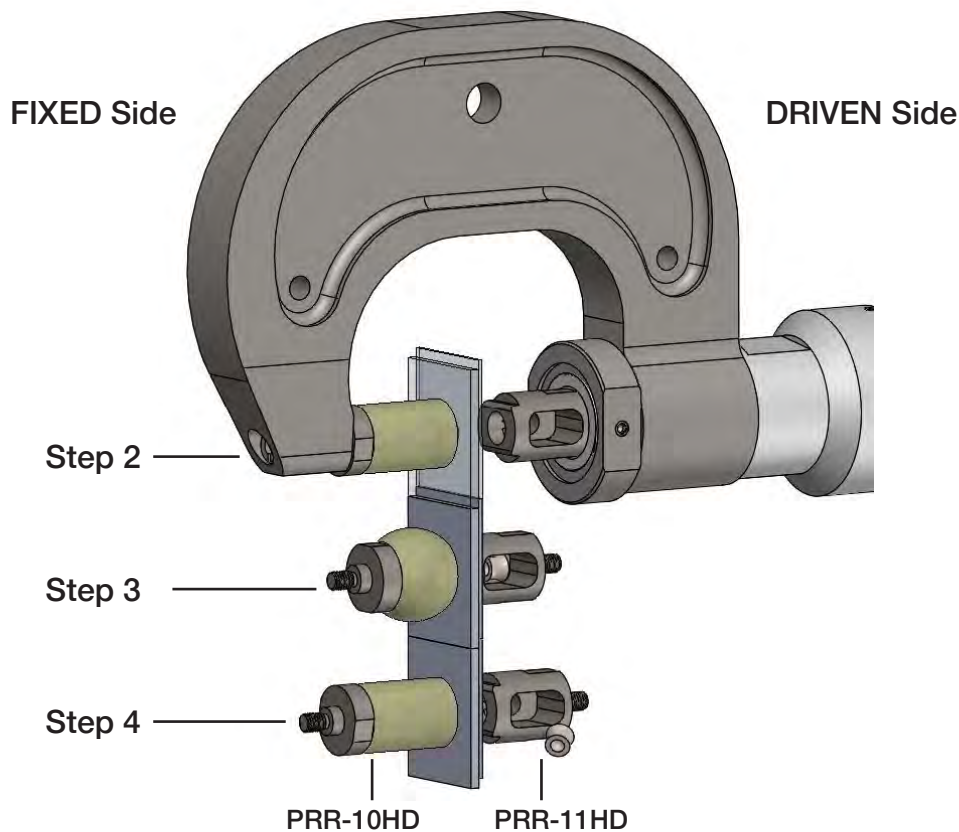
**STEP ONE:**

Install the PRR-10HD on the FIXED side of the arm. Do not use an Extension Die. Install the PRR-11HD on the DRIVEN side of the gun.

STEP TWO:

Engage the alignment pocket of the PRR-10HD on the formed side of the rivet. The counterbore should fit snug around the formed side (inside of the vehicle typically).

STEP THREE:

Pull the PR-5D gun trigger. The ram will extend and the elastic plastic spring will compress.

ONCE THE RIVET RELEASES FROM THE PANEL, LET GO OF THE TRIGGER.

STEP FOUR:

Press the manual retract button on the PR-5D to return the ram to the retracted position. The elastic plastic spring will return to the uncompressed state and draw the PRR-10HD out of the hole that the rivet was extracted from.

Sheet Flattening Procedure:

1. Make sure rivet gun ram is fully retracted. If it is not, press Manual Retraction Button. (Shown in Section 2.3 item #10)
2. Install Flattening Die on Piston Side. **TIGHTEN THREADS FULLY OR DAMAGE TO DIE/PISTON RAM THREADS WILL OCCUR!**
3. Install Flattening Die on Fixed Side. **TIGHTEN THREADS FULLY OR DAMAGE TO DIE/PISTON RAM THREADS WILL OCCUR!**
4. Bring gun arm assembly to the work piece joint to be flattened. Position in location. Squeeze rivet gun trigger to extend ram until rivet meets the sheet to flatten. Continue to hold trigger until flattening process is completed and ram retracts.

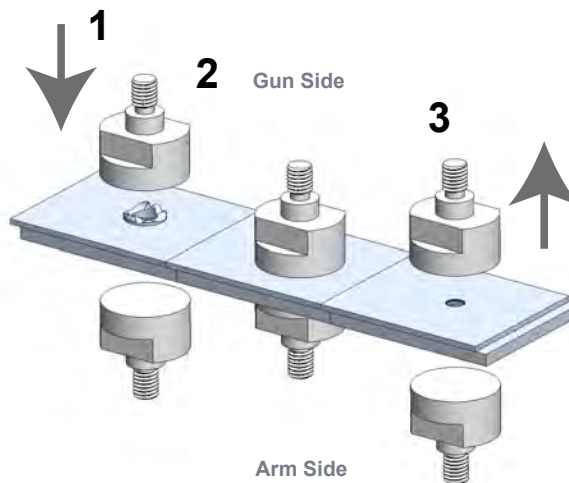
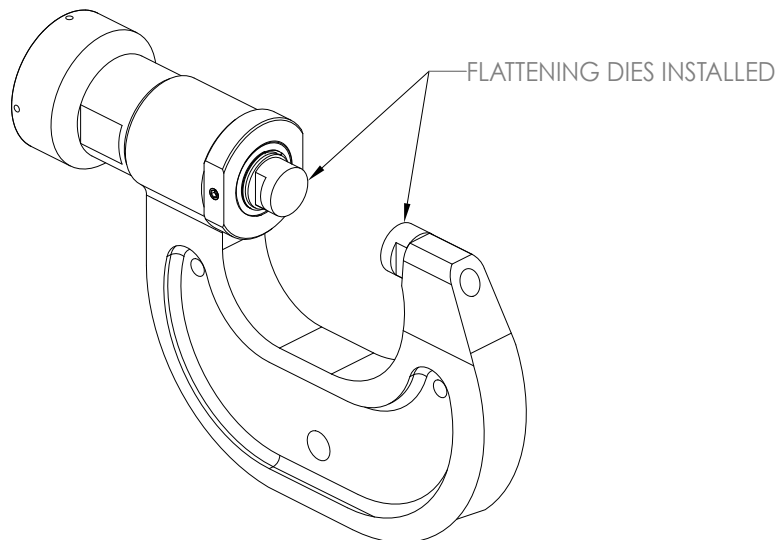

Calibration Hole Procedure:

1. Align the calibration dies in the center of hole.
2. Complete pressure cycle to make exact hole size and collect the punch ring for reuse.
3. The hole is now ready for Flow Form rivet installation.

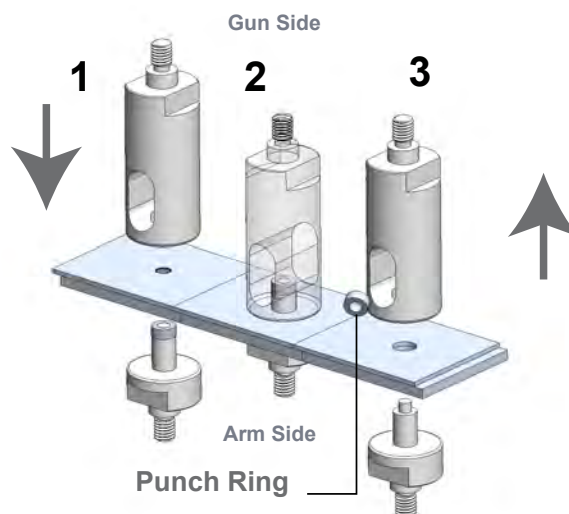
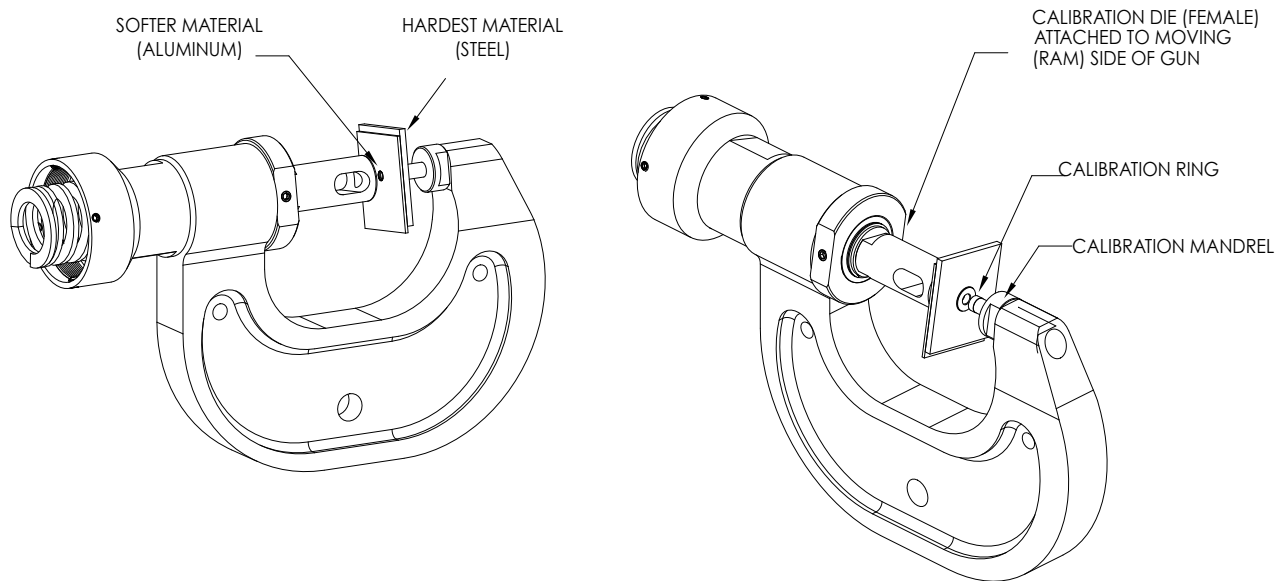

Flow Form Installation Procedure:

1. Place Flow Form rivet in calibrated hole.
2. Align head side die with flow form die.
3. The installation of the Flow Form rivet is now completed.

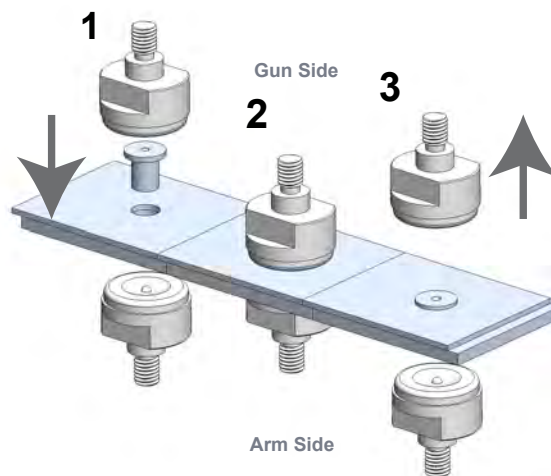
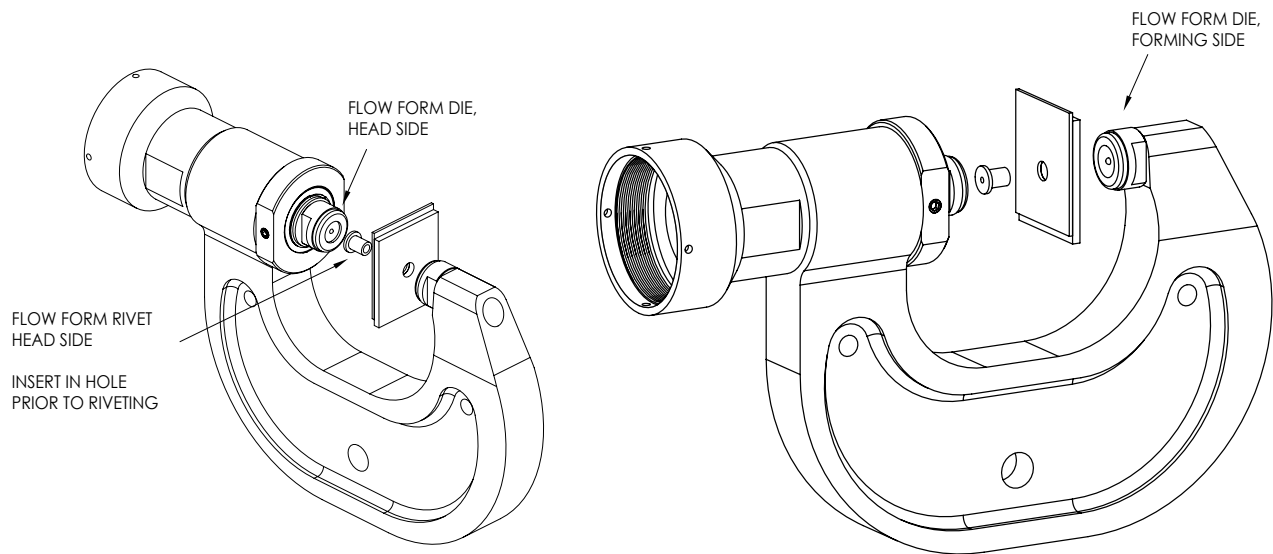



WARNING! All service and maintenance must be carried out by Pro Spot service personnel and service support. Risk for electrical shock.

Do not disassemble any of the components without authorization. Any damage caused by misuse or disassembly is not covered under warranty.

- Keep the rivet gun dry. If the device happens to get wet, remove the battery and only install the battery after the entire rivet gun is completely dry.
- Do not use or store the device in extreme hot or cold temperatures. Both conditions will cause plastic housing to deform, shorten the service life of the electronic components and damage the battery.
- CLEAN ADHESIVE RESIDUE PRIOR TO SETTING/DRYING ON TOOL.



Pro Spot International, Inc.
5932 Sea Otter Place
Carlsbad, CA 92010

Toll Free: (877) PRO SPOT
Phone: (760) 407-1414
Fax: (760) 407-1421

E-mail: info@prospot.com
Web: www.prospot.com