



Instruction Manual

i5s Retrofit Kit and ELA Assembly

MNL-ELA-i5s Ver. 1.1



About Pro Spot

Pro Spot International specializes in quality welding and repair products for the collision repair industry. Pro Spot owns numerous patents for special welding equipment and applications, and works with the largest auto manufacturers in the world. Pro Spot is a proud 'MADE IN THE USA' manufacturer in Carlsbad, CA. The turnkey facility includes Design, Engineering, Machine and Sheet Metal Shops, Powder Coating, Assembly, Training and Customer Support. The Pro Spot equipment line includes resistance spot welders, aluminum & steel dent repair systems, pulse MIG welders, rivet guns and tools, dust-free sanding systems, fume extraction and more.

Pro Spot Training and Services

Pro Spot provides on-going training to all of our distributors and their technicians, therefore, all owners of Pro Spot products receive complete training first hand. Pro Spot has two ASE certified training programs that are I-CAR Alliance approved. Pro Spot has a fully equipped training facility at their Headquarters in Carlsbad, CA, as well as in Nashville, TN, and Denver, CO, for groups to come in and train on all products. To stay up-to-date, Pro Spot offers their unique my.prospot.com which includes interactive training courses for shops and technicians to access online.

Pro Spot is constantly striving to improve. Whether that means designing innovative equipment, implementing cutting edge technical support or further improving their already extensive training programs, Pro Spot is always looking for ways to better our customer's experiences.



PRO SPOT

QUALITY WELDING SYSTEMS

Pro Spot International, Inc.
5932 Sea Otter Place
Carlsbad, CA 92010

Toll Free: (877) PRO SPOT
Phone: (760) 407-1414
Fax: (760) 407-1421

E-mail: info@prospot.com
Web: www.prospot.com

TABLE OF CONTENTS

1.0 INTRODUCTION	3
1.1 About ELA-i5s	3
1.2 Warnings	3
2.0 i5s BASE ASSEMBLY	4
2.1 Components	4
2.2 Tools for Assembly	4
2.3 Retrofitting the i5s Base	5
3.0 ELA INFORMATION	11
4.0 ELA ASSEMBLY	13
4.1 Components	13
4.2 Tools for Assembly	13
4.3 ELA Assembly Instructions	14
5.0 OPERATING INSTRUCTIONS	18

1.1 ABOUT ERGO LIFT ASSIST

The revolutionary Pro Spot Ergo Lift Assist™ System (ELA) is the tallest and most versatile motorized boom mechanism for spot welding applications. Designed to reach higher (9.25' / 2.82 m) and lower (5' / 1.5 m) than most conventional booms, the ELA makes spot welding any area on today's high reach / wide footprint vehicles accessible and ergonomically friendly.

- The tool balancer and pivot arm are uniquely designed to make lifting and holding the weld gun light and easy, no matter the location on the vehicle.
- Muscle strain is reduced and injuries are prevented due to the ergonomic design and functionality of the ELA. As a result, job performance and satisfaction are significantly improved.
- The ELA is powered by either wall outlet or battery power, allowing mobility and boom control anywhere and anytime around the shop without being tethered to an inconvenient electrical outlet.
- The extended reach arms allow work to be done far away from the welder, keeping the area around the vehicle clear and accessible.
- The ELA engineering solution provides a low center of gravity weight distribution to keep the welder balanced, stable and safe at all limits of the ELA's reach.
- There are retrofit kits available to add the ELA to the Pro Spot i5 and i5s spot welders.
- Pro Spot's Ergo Lift Assist™ is designed, engineered and manufactured in the USA.

1.2 WARNINGS



- **The new welder base MUST be installed prior to ELA installation.**
- **Never install ELA on the welder with the old base to prevent a tipping hazard.**
- Tool balancing system only designed to support the weight of the Pro Spot welding gun (60 lbs / 27 kg MAX).
- Do not hang from or pull down on any part of the tool balancing system.
- Make sure you are aware of any pinching points on the boom.
- Return tool balancing system above 7 feet / 2.1 m prior to storing the machine.
- Always holster the spot welding gun when not in use. Raise the tool balancing system to secure the spot welding gun in the holster.
- Do not disconnect the tool balancer cable from the spot welding gun without keeping tension on the cable and slowly retracting the cable up the the boom.
- Make sure that the boom is not going to come in contact with anything when raising or lowering the boom.
- Make sure that the boom is not going to come in contact with anything while moving the welder to a different location.
- Make sure that the spot welding gun is not going to come in contact with anything while it is hanging from the balancer cable. Make sure to holster the spot welding gun prior to moving the welder.
- When locking the casters of the welder, be sure that there is enough range of motion to operate the boom without having to pull the tool balancer cable to the side.
- The tool balancer cable should always remain vertical and not pulled to the side.
- Do not use a defective battery on the boom.
- Properly dispose of defective batteries.
- Strictly adhere to the designated functions outlined in our manual and website; avoid using the stand for any other purposes.
- Avoid utilizing substitute parts; in case of replacement requirements, reach out to the manufacturer for authentic replacement parts.

2.1 COMPONENTS OF RETROFIT KIT FOR i5s BASE - SA-0840

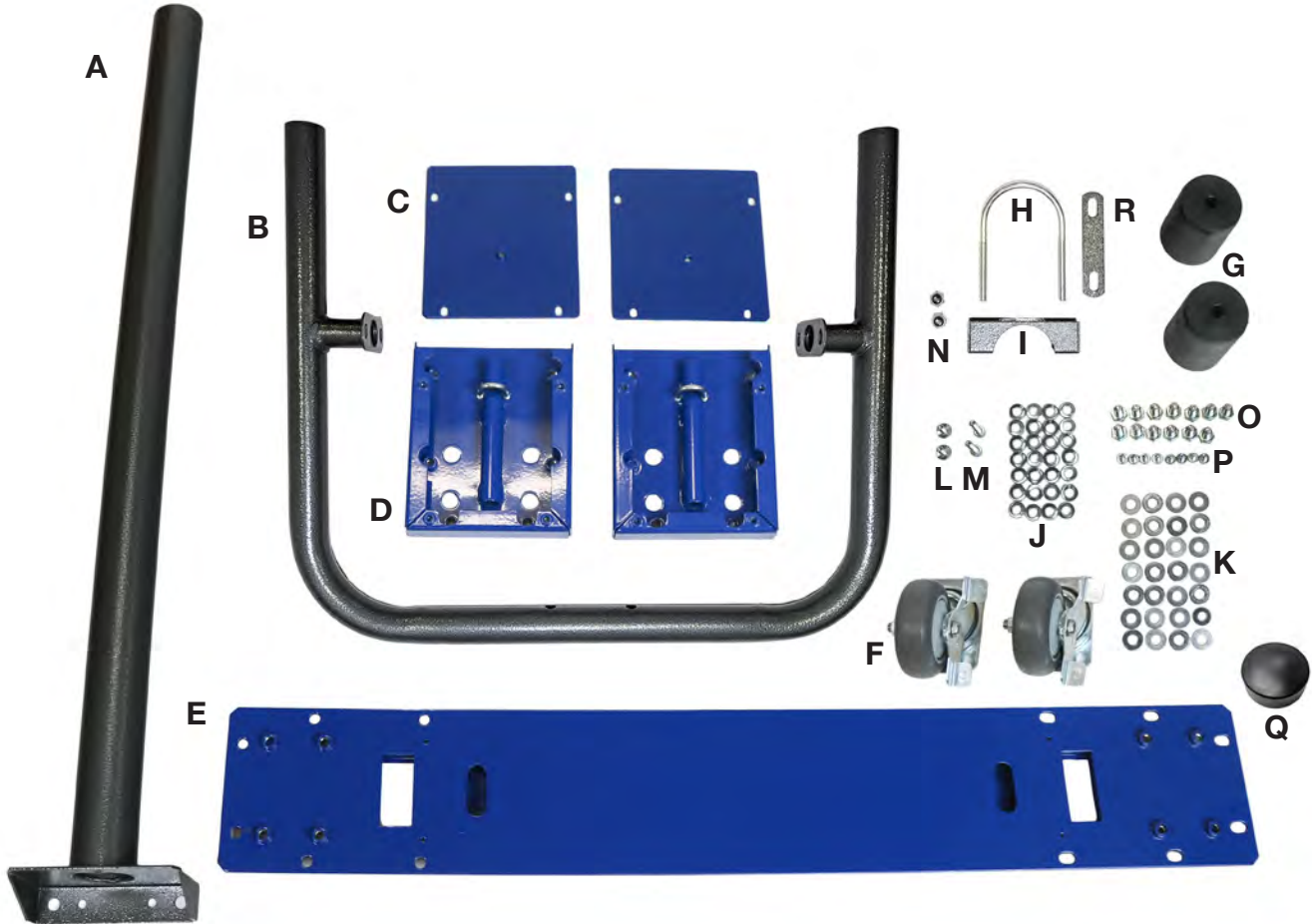

- | | | |
|--|----------------------------|-----------------------------------|
| A. 90-2678 Lower Boom | F. P10-05 Casters | N. N-102 Nuts with protective Cap |
| B. 90-2688 Wrap Around Handle | G. 90-0355 Arm Sockets | O. S-372 16mm Screws |
| C. 90-2693 Cover Plates | H. 90-2694 U-Bolt | P. S-170 Screws |
| D. 90-2691 Brackets with P-05 U-Bolts, W-20 Washers, N-06 Nuts | I. 90-2689 - Bracket | Q. 52-0126 Cap |
| E. 90-2692 Caster Plate | J. W-19 Lock Washers | R. S-230 U-Bolt Plate |
| | K. W-16 Flat Washers | |
| | L. S-232 Whiz Flange Bolts | |
| | M. S-89 Screws | |

2.2 TOOLS FOR ASSEMBLY (not included)



1. 5 mm Allen Key
2. Ratchet with 7/16" & 13mm Sockets
3. Diagonal Cutters
4. P1 Flathead screwdriver
5. #2 Phillips head screwdriver or power drill with #2 Phillips head tip.
6. Needle Nose Pliers
7. 7/16" open end wrench

2.3 RETROFITTING THE i5s BASE

I. Casters Installation

Install the casters (F) on the bottom of the long Caster Plate Weld Assembly (E).

Use the S-170 screws (P) with lock washers W-19 (J) and flat washers W-16 (K).

Use Phillips head screwdriver or power drill to tighten.



II. Preparing the welder

Lift up the welder so the two rear wheels are off the ground. You may use the box, a pallet jack or straps with the help of a forklift.



WARNING: TIPPING HAZARD.

Be sure to stabilize the welder on the front with counter weights or with the assistance of additional personnel.



III. Removing the wheels

1. Once the welder is safely lifted off of the ground, use diagonal cutters (3), flat head screwdriver (4) or needle nose pliers (6) to remove the cotter pins on both ends of the axle.

2. Remove the large wheels and washers from the axle.



IV. Axle Brackets Installation

1. Install the Axle Housing Brackets 90-2691 (D) on both ends of the axle, (U-bolt should already be installed loosely from the factory), keep U-bolt loosened.

2. Make sure that the ledge of 90-2691 (D) is under the existing base.

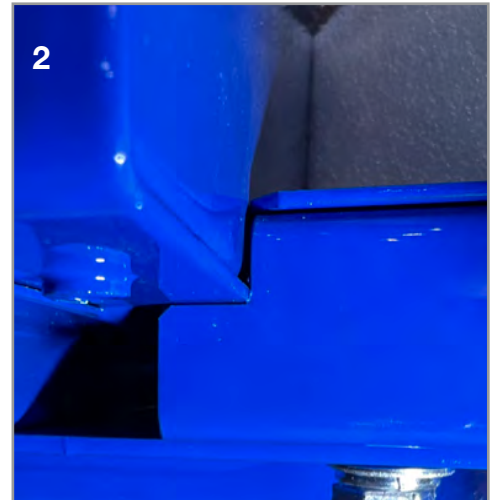
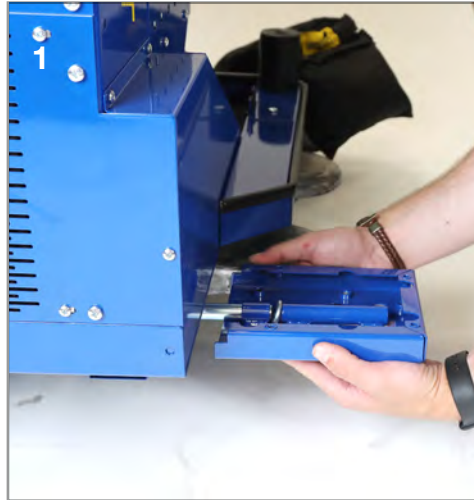

V. Caster Plate Installation

Secure the caster plate with the S-372 HHCS screws (O), W-19 lock washers (J) and W-16 washers (K) using a ratchet and 13 mm socket to tighten and secure the hardware.

Tip: Hold the middle with one hand and install screws, W-19 lock washers (J) and W-16 washers (K) with the other hand. Repeat the process on the other side.



VI. U-Bolt Tightening

Tighten the U-Bolts with the ratchet and 7/16" socket to secure. The nuts and washers will be pre-assembled from the factory.

It is important to tighten the U-bolt so that it is level.

You may need to alternate when tightening each nut to achieve this.

Once all of the screws on the Casters, U-bolt and Caster Plate have been sufficiently tightened and secured, you may lower the welder to the floor for the remainder of assembly.



VII. Installing Top Cover Plates

Place the top plates (C) over the fully assembled axle housing bracket.

Use the S-209 screws (R) to secure. Tighten with Phillips head screwdriver.



VIII. Installing Arm Support

Use the S-89 (I) to install the arm socket (D) on top of the top plate.

Tighten with 5 mm Allen key.



IX. Removing the Weld Gun Holster

1. Unscrew the two screws to remove the Weld Gun Holster. **Be sure to keep BOTH plastic insulating bushings with the screws as you will need to re-use them.** There are four total plastic insulating bushings.

2. Once you have unscrewed the holster from the handle. Lift the holster up to release the plastic clamps from the handle.



X. Top Cover Removal

1. Remove the screws from the top cover using a Phillips screwdriver.
2. Remove the cover off of the welder. We recommend using two people for this step.



XI. Rear Handle Removal

1. Remove the screws connecting the handle to the welder using a Phillips screwdriver. Repeat the process on the other side of the welder.
2. Remove the rear handle, making sure to slide it out carefully.

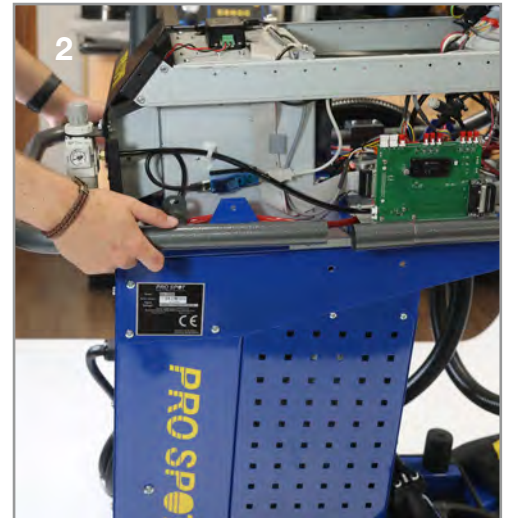
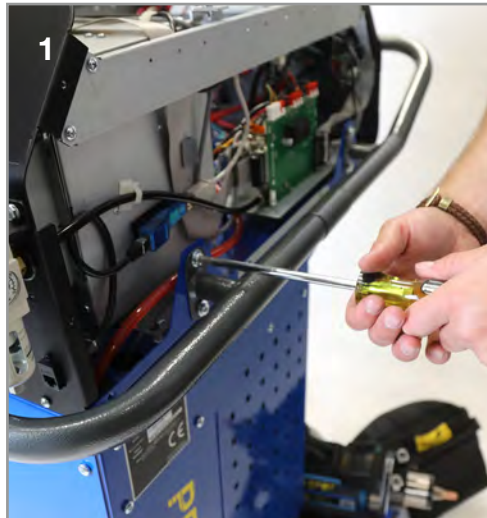

XII. Wraparound Handle Assembly

Install the U-bolt 90-2694 (H) onto the new Wraparound Handle (B) with bracket (I). The U-bolt plate (R) should be placed on the outside of the handlebar, followed by the washers (K), then lock washers (J) and finally hex nuts (N). Keep the assembly loose.

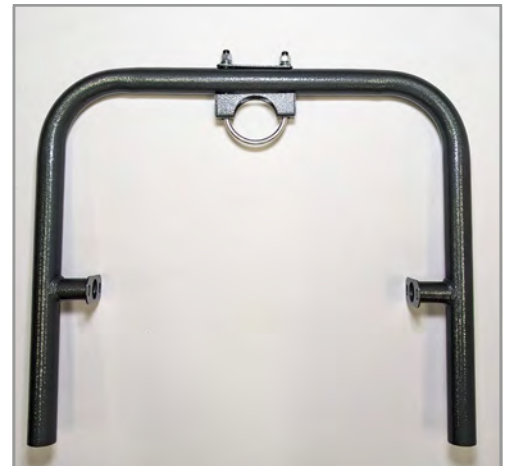

XIII. Installation of the Wrap-around Handle

Install the Wraparound Handle (B) with U-bolt (H) onto the welder and loosely secure with washers, lock washers and screws.

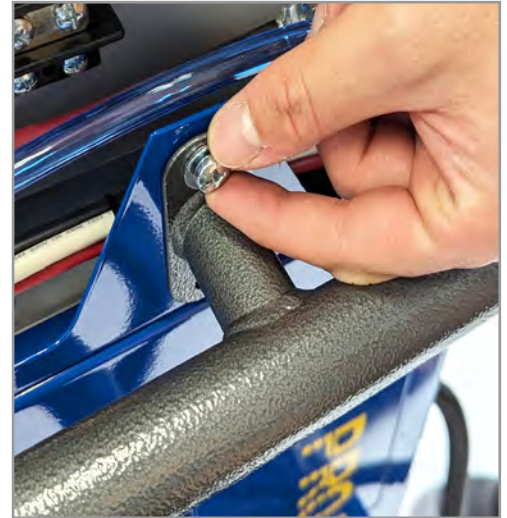

XIV. Installing the Lower Boom Rear Handle Mount.

1. Remove the screw in the back of the welder using a Phillips screwdriver. It is located at the rear bottom center of the welder.
2. Install the Lower Boom Rear Handle Mount (A) onto the back of the welder by threading it through the U-Bolt on the installed wraparound handle and securing them with S-232 Whiz Flange Bolts (L).
3. Leave the screws and washers loose for now.

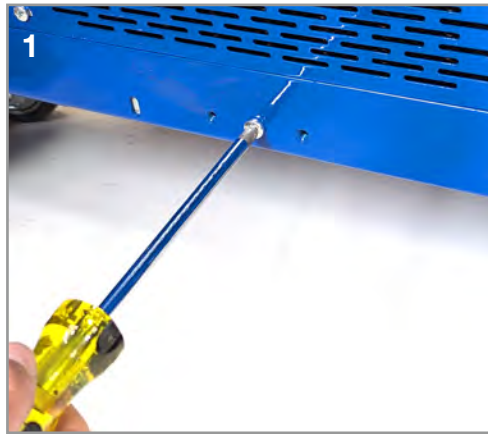

XV. Tightening the Screws

Once you have aligned the Lower Boom Rear Handle Mount and Wraparound Handle with U-bolt, tighten the screws to secure.



XVI. Top Cover Installation

1. Re-install the top welder cover.
2. Use the Phillips Screwdriver to secure the top cover.



XVII. Reinstalling the Weld Gun Holster

1. Push the holster down to snap onto the new handle. Align the holes to match up with the welder.
2. Place the plastic insulating bushing between the holster and the welder for each screw.
3. Place the other plastic insulating bushing on the screw and tighten to secure.

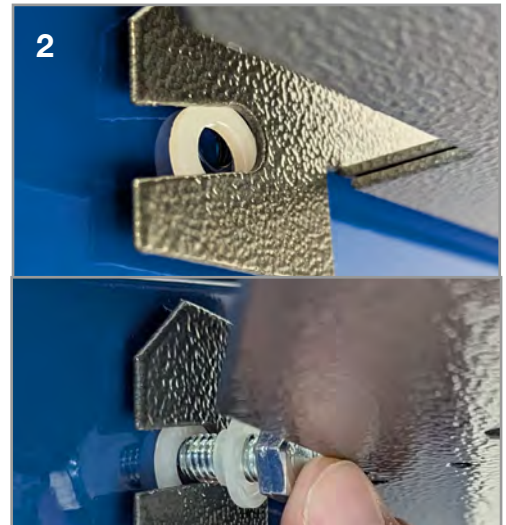

⚠ IMPORTANT! Insulating bushings MUST be installed correctly to properly insulate gun holster from the welder chassis.

XVIII. Installing Plastic Cap

Use the cap 52-0126 (Q) to cover the opening on the old boom holder on the back of the welder.



**IMPORTANT:**

The base **MUST** be installed prior to ELA installation.

Never install ELA on the welder with the old base to prevent a tipping hazard.

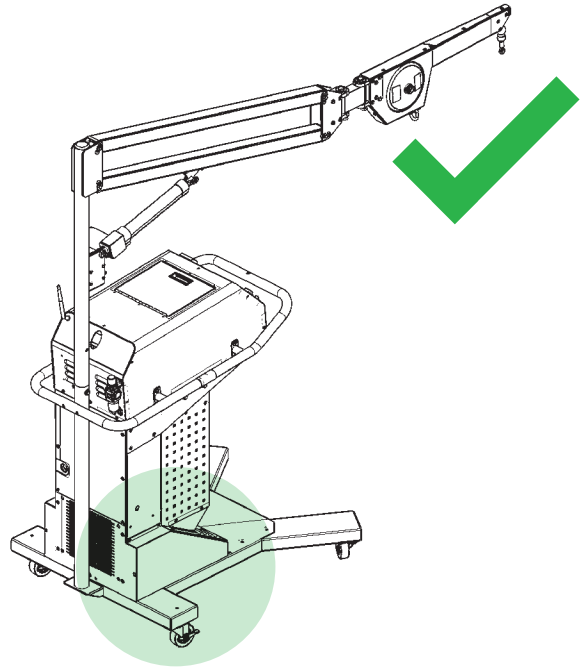
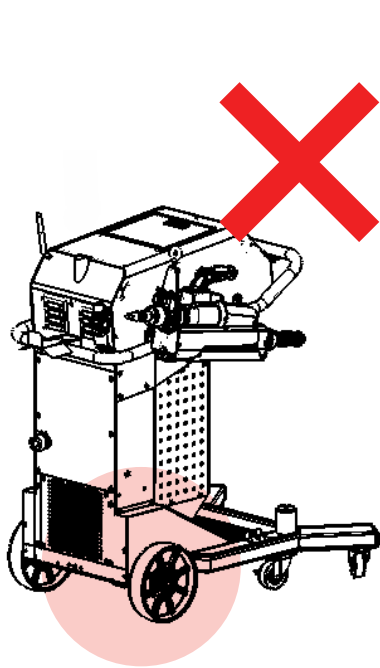

ELA must only be mounted and used pointing to the front of the welder.

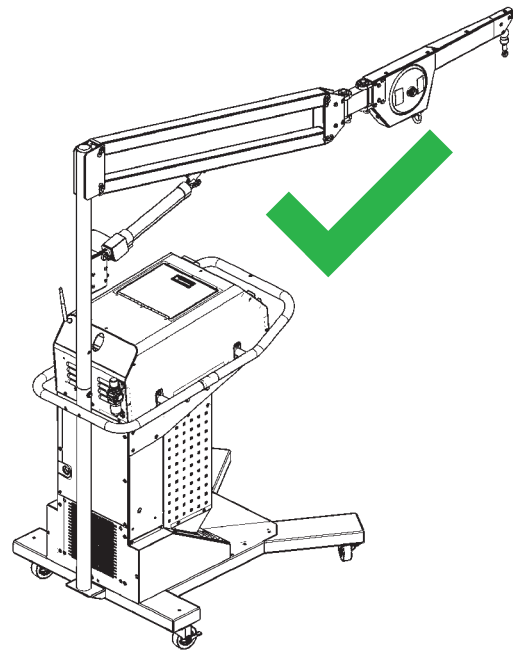
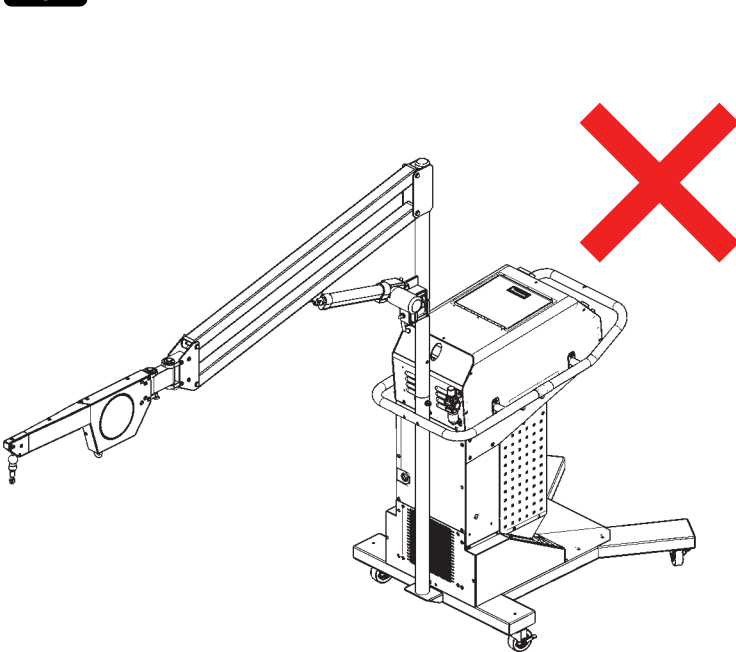

1.3 ELA DIMENSIONS

- Weight: 52 lbs / 23.5 kg
- Height fully extended: 9' / 2.75 m
- Height in the lowest position: 5' / 1.5 m
- Reach fully extended (from the handle): 2' 10" / 0.86 m
- Reach in the lowest position: 4' 3" / 1.3 m

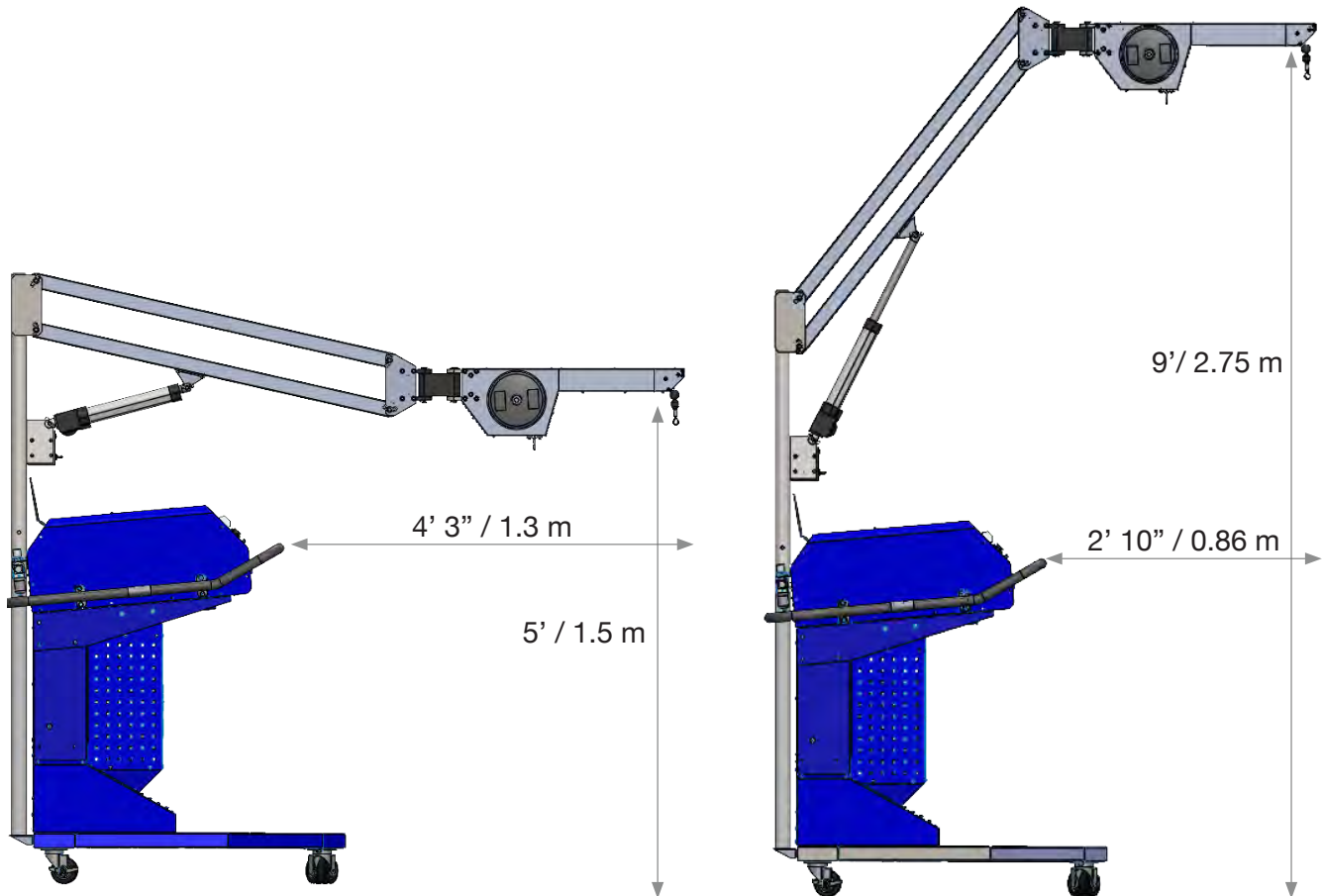

4.1 ERGO LIFT ASSIST™ COMPONENTS



- A. SA-0823 - Elbow Boom/Tool Balancer Kit
- B. 90-2672 - Upper Arm
- C. 90-2673 - Lower Arm
- D. SA-0828 - Actuator/Battery Box Assembly
- E. PRR-22 - Battery Charger & PRR-21 - 18v Battery w/ charge indicator
- F. 77-0024 - Power supply adapter, 24v 5A 120W output, 85-264 VAC Input, 69-0002 - Power Cord, 90-2690 - Bracket, Power Supply Mount
- G. PS-005 - Weld Cable Saddle with (x2) C-09 Carabiner
- H. 51-0185 - Clevis Pin 1/2"x2-1/2"
- I. 51-0179 - Clevis Pin 10 mm x 40 mm
- J. W-141 Washer
- K. 51-0188 - Bow Tie Cotter Pin
- L. 52-3211 - License Plate Nuts and S-12 Screws
- M. S-282 Hex Bolt, W-05 Washers, W-14 Lock Washer, N-08 Hex Nut.
- N. 52-0620 Bushings
- O. 90-2676 - Vertical Boom Support
- P. 51-0191 - Hook and Loop Cable Tie

4.2 TOOLS FOR ASSEMBLY (NOT INCLUDED)



- 1. #2 Phillips Screwdriver
- 2. 9/16" Ratchet/Wrench

4.3 ELA ASSEMBLY INSTRUCTIONS

I. Installing the Bushings

Place the bushings (N) in the holes at each end of the Upper Arm and Lower Arm.



II. Securing the Actuator to the Vertical Boom Support.

1. Line up the lower portion of the Actuator to the mounting holes on the Vertical Boom Support.
2. Place the 10mm x 40mm Clevis pin (I) through the hole.
3. Secure with the Bow Tie Cotter Pin (K).



IMPORTANT: Be sure to attach the **SHORTER** side (labeled A) of the Lower Arm with the Vertical Boom Support (labeled A). Failure to do so will result in severely shortened range of motion and product damage.



III. Installing the Lower Arm

1. Line up the Lower Arm with the bottom set of holes of the Vertical Boom Support.
Be sure the Bushings (N) on the lower arm are in place before installing Clevis pins.
2. Place a ½" x 2 ½" Clevis pin with a washer through the holes (H, J).
3. Secure the Clevis pin with a washer and a Bow Tie Cotter Pin (J, K).

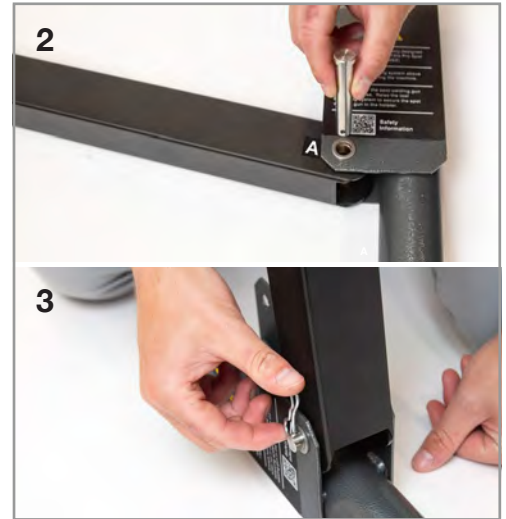

IV. Attaching the Actuator to the Lower Arm

1. Align the upper portion of the Actuator (D) to the triangular Actuator Mount on the bottom side of the Lower Arm (C).
2. Place the 10mm x 40mm Clevis pin through the holes (I).
3. Secure the Clevis pin with the Bow Tie Cotter Pin (K).

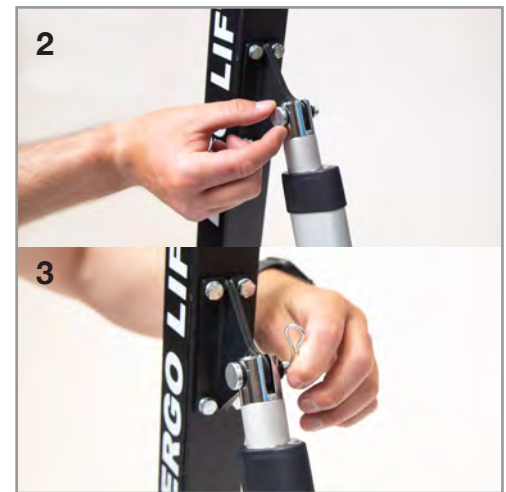

V. Installing the Upper Arm

1. Align the Upper Arm (B) to the top holes on the Vertical Boom Support.
Be sure the Bushings are in place on the upper arm before installing Clevis pins (N).
2. Place a ½" x 2 ½" Clevis pin with a washer through the holes (H, J).
3. Secure the Clevis pin with a washer and a Bow Tie Cotter Pin (J, K).



VI. Attaching the Boom Elbow/Tool Balancer

1. Align the Upper and Lower arms to the Elbow Boom/Tool Balancer Kit.
Be sure the Bushings are in place before installing Clevis pins (N).
2. Place the Clevis pins with washers through the holes (H, J).
3. Secure the Clevis pins with washers and Bow Tie Cotter Pins (J, K).



VII. Installing the Boom on the Welder

1. Install the fully assembled ELA into the lower tube facing the front of the welder.
Two people recommended for this step.
- IMPORTANT! ELA must only be mounted and used pointing to the front of the welder (See p. 11).**
2. Rotate the boom so it faces forward and the hole in the boom aligns with the hole in the post. Install the Hex Bolt (M) with a washer through the holes.
Place a washer and the lock washer on the end of the Hex Bolt (M). Then place the Hex Nut on the end (M).
 3. Use the 9/16" ratchet and 9/16" open-end wrench to tighten the bolts.



WARNING: Operating ELA without securing Hex bolt can lead to tipping and SERIOUS INJURY.

VIII. Installing the Power Supply

1. Use the license plate nuts and screws (L) to install the Power Supply.
2. Pull the Power Supply Cable through the inside of the handle bar and plug it into the power inlet on the backside of the Battery Box.

Tip: You may use zip ties to secure the power cable to the Vertical Boom Support.

3. Charge the battery with supplied battery charger prior to use and place it in the battery holder.

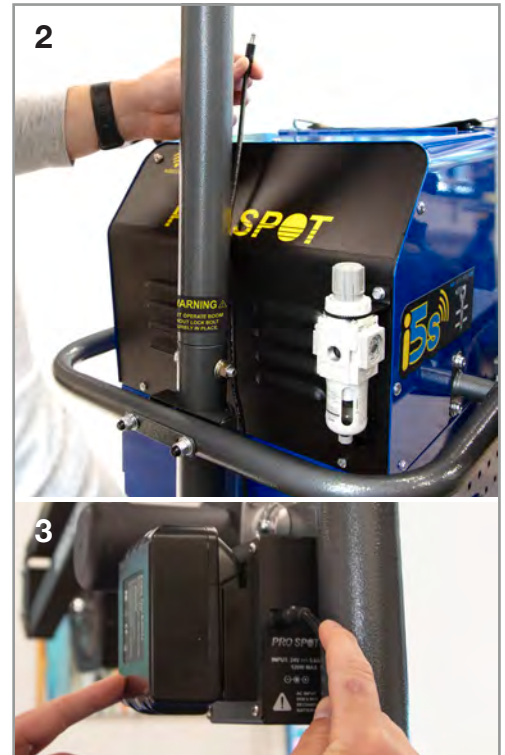
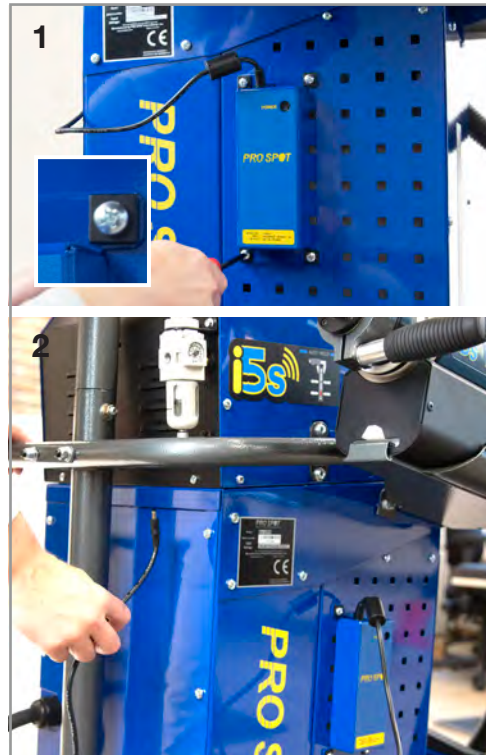

IX. Installing the Weld Cable Saddle

1. Attach the Weld Cable Saddle to the hook underneath the Tool Balancer.
2. Loop the Weld Cable Saddle around the weld cable.
3. Attach the second carabiner to secure it.



X. Attaching the Weld Gun to the Tool Balancer Cable

Attach the Tool Balancer Cable to the Weld Gun using the carabiner.





WARNING: Tool balancing system is only designed to support the weight of the Pro Spot welding gun. (60 LBS / 27 KG MAX).

Do not hang from or pull down on any part of the tool balancing system.

Make sure you are aware of any pinching points on the boom.

4.1 OPERATING ERGO LIFT ASSIST

All the following operations must only be carried out by trained and qualified personnel.

Failure to comply with the instructions below or tampering with the pneumatic connections, exempts the manufacturer from any liability for non-compliance or damage caused by malfunctioning of the equipment.

The Ergo Lift Assist™ is designed to ergonomically and safely hold the weight of the spot welding gun at various heights and positions.

The Ergo Lift Assist™ can be operated using the 18 volt battery or the supplied 110-240 volt power adapter. The battery and the power adapter can be plugged in at the same time. To charge the battery (Makita Style 18V - PRR-21), it must be removed from the battery holder and charged with the supplied battery charger.

Use the Up/Down switch to get the boom into a comfortable position to be able to pull the balancer cable and attach it to the spot welding gun.



The Tool Balancer tension is set to 11-13 kg for shipping. It may be adjusted as needed (+/- 1 kg).



To move the Ergo Lift Assist up and down, use the up / down switch located on the vertical boom support assembly.

All maintenance and repair work must be carried out by authorized Pro Spot personnel who have read this manual and the operating instructions.



Pro Spot International, Inc.
5932 Sea Otter Place
Carlsbad, CA 92010

Toll Free: (877) PRO SPOT
Phone: (760) 407-1414
Fax: (760) 407-1421

E-mail: info@prospot.com
Web: www.prospot.com