



SHIPPING DATA:

Box 1 Dimensions: 39"x15.5"x29" Weight: 168lbs. (76 Kg.)

Box 2 Dimensions: 21"x12"x7.5" Weight: 25lbs. (11 Kg.)

SP-5 DP Serial # Checked By/Date:

Instruction Manual

Cart Parts

90-0579 : Tow Handle  1 ea.

Box 2 Contents

51-7002 : Rear Wheel-9" Dia.  2 ea.

51-7001 : Swivel Caster  2 ea.

90-0555 : Bottle Bracket  1 ea.

90-0622 : Boom Tube Base  1 ea.

90-0602 : Base w/ 90-0624 : Plastic Shroud  1 ea.

90-0604 : Axle  1 ea.

90-0554 : Trolley, Bottles  1 ea.

51-0031: Boom Hardware Kit  1 ea.

Box 1 Contents

Torches and Cables

82-7015 : Silicon Bronze Torch Red (9 ft.)  1 ea.

82-7016 : Steel Torch Green (9 ft.)  1 ea.

82-7025 : Aluminum Torch Blue (9 ft.)  1 ea.

82-7027 : Ground Cable  1 ea.

Hardware and Spare Tips (Included)



Consumable Kit : SA-0506

50-7006 : CONTACT TIP, 0.6MM / 0.023"  50-7008 : CONTACT TIP, 0.8MM / 0.030" 

50-7111 : CONTACT TIP, ALU, 1.0mm (0.040")  50-7112 : CONTACT TIP, ALU, 1.2mm (0.045") 

S-88 : SCREW, SHCS, M6 x 20, Zinc  51-5419 : HOSE CLAMP, 7/32" - 5/8" RANGE  1 ea.

Adapter Kit : SA-0508

83-5081 : Gas Connector  83-4013 : 3 pin Male Connector  1 ea.

82-7001 : Gas Regulator  2 ea.

50-7037 : Silicon Bronze 1.0mm - 2kg  1 ea.

50-7208 : Mild Steel 0.8mm - 5kg  1 ea.

50-7117 : Aluminum 5554 1.2mm - 2kg  1 ea.

Box 2 Contents

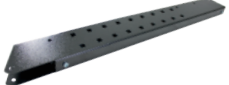

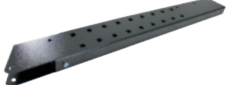

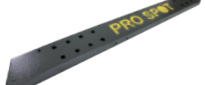

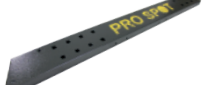
90-0615 : Vertical Hanger (Side 1)  1 ea.

90-0616 : Vertical Hanger (Side 2)  1 ea.

90-0613 : Top Hanger (Side 1)  1 ea.





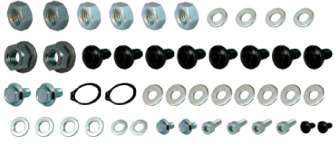



90-0614 : Top Hanger (Side 2)  1 ea.

Box 2 Continued...







<input type="checkbox"/> 90-0612 : Hanger Tube  1 ea.	<input type="checkbox"/> 90-0617 : Hood Hanger  2 ea.	<input type="checkbox"/> 90-0618 & 90-0619 : Torch Saddle Hooks  1 ea.	<input type="checkbox"/> 90-0241 : Parts Bin Tray  2 ea.
<input type="checkbox"/> 90-0620 & 90-0621 : Cable Channels  1 ea.	<input type="checkbox"/> M-88: 35" Chain  2 ea.	<input type="checkbox"/> Base Hardware Kit  1 ea.	

Parts and Consumables

Steel & Silicon Bronze (Green & Orange) Torch

<input type="checkbox"/> 50-7002 : Blue Liner 0.6 - 0.9 mm Steel only  1 ea.	<input type="checkbox"/> 50-7011 : Nozzle for Plus 15 Torch  1 ea.	<input type="checkbox"/> 50-7207 : Wire Feed Roller - for Steel 0.6 - 0.8 mm / 0.023 - 0.030 in <input type="checkbox"/> 50-7209 : Wire Feed Roller - for Steel 0.8 - 1.0 mm / 0.030 - 0.040 in  1 ea.
<input type="checkbox"/> 50-7015 : Torch Neck for Plus 15 (Included 50-7152 : Gas Diffuser Spring)  1 ea.	<input type="checkbox"/> 50-7006: Contact Tip 0.6 mm / 0.023 in <input type="checkbox"/> 50-7008: Contact Tip 0.8 mm / 0.030 in	<input type="checkbox"/> 50-7151 : Gas Diffuser for 1.4 Plus 15 Torch (Spring 50-7152 NOT Included)  1 ea.
<input type="checkbox"/> 50-7021: Red Teflon Liner 0.08mm - 1.2mm <input type="checkbox"/> 50-7005: Red Liner 1.0mm - 1.2mm   1 ea.		<input type="checkbox"/> 50-7152 : Gas Diffuser Spring  1 ea.

Aluminum (Blue) Torch

<input type="checkbox"/> 50-7001 : Graphite Liner 1 - 1.2 mm  1 ea.	<input type="checkbox"/> 50-7114 : Nozzle for Plus 25 Torch  1 ea.	<input type="checkbox"/> 50-7109 : Wire Feed Roller - for Aluminum 0.8 - 1.0 mm / 0.030 - 0.040 in <input type="checkbox"/> 50-7118 : Wire Feed Roller - for Aluminum 1.0 - 1.2 mm / 0.040 - 0.045 in  1 ea.
<input type="checkbox"/> 50-7025 : Torch Neck for Plus 25  1 ea.	<input type="checkbox"/> 50-7113 : Contact Tip for Aluminum Wire 0.8 mm / 0.030 in <input type="checkbox"/> 50-7111 : Contact Tip for Aluminum Wire 1.0 mm / 0.040 in <input type="checkbox"/> 50-7112 : Contact Tip for Aluminum Wire 1.2 mm / 0.047 in  1 ea.	<input type="checkbox"/> 50-7251 : Gas Diffuser M8 for Plus 25 Torch <input type="checkbox"/> 50-7024: Gas Diffuser Spring   1 ea.

Copyright 2018 Pro Spot International Inc. Rev.C. 12/11/2024

Available Wire

50-7108 : Aluminum
 4043 0.8mm / 0.030 in - 2kg



50-7110 : Aluminum
 4043 1.0mm / 0.040 in - 2kg

50-7107 : Aluminum 5554
 1.0mm / 0.040 in - 2kg



50-7117 : Aluminum
 5554 1.2mm / 0.047 in - 2kg

50-7115 : Aluminum
 5356 1.0mm / 0.040 in - 2kg



50-7208 : Mild Steel
 0.8mm / 0.030 in - 5kg



50-7038 : Silicon Bronze
 0.8mm / 0.030 in - 2kg

50-7037 : Silicon Bronze
 0.8mm / 0.030 1.0mm - 2kg



SP-5 DP Optional

82-7017 : TIG Torch (13 ft.)



1 ea.

82-7014 : Stick / MMA Cable (10 ft.)



1 ea.

TIG Torch

50-7301 : Tungsten Electrode, TIG



50-7302 : TIG Collet 1.6mm



50-7303 : TIG Collet Body, 1.6mm



50-7304 : Ceramic Nozzle



50-7305 : Electrode Cap



PS Protective Covers (optional)

80-9912 : Protective Cover
 Heavy duty, high quality material

