



Component List

CL-i4s Rev C.

PRO SPOT

ORDER ONLINE @ store.prospot.com



i4s Serial #

Checked by:

PS-3201-3

Single-Sided Gun Assembly



CLP-70

Spot Hammer

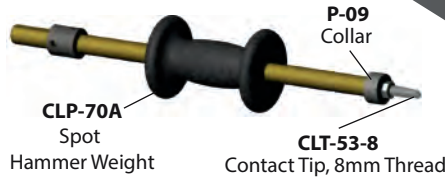

SA-0612

Tool Balancer 8-10kg



SHIPPING DATA:
 Dimensions: 48" X 40" X 60"
 Weight: 385 lb (175 kg)

PS-700W

Spot Welding Gun, Liquid Cooled

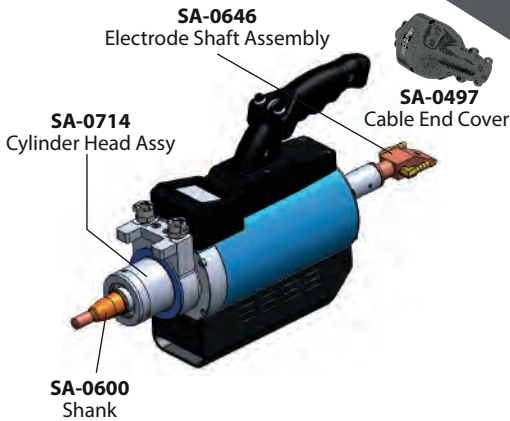

80-0001

Welder Cover



SA-0642

Overhead Boom



PSW-080

C-Arm Assembly, 80mm Extension

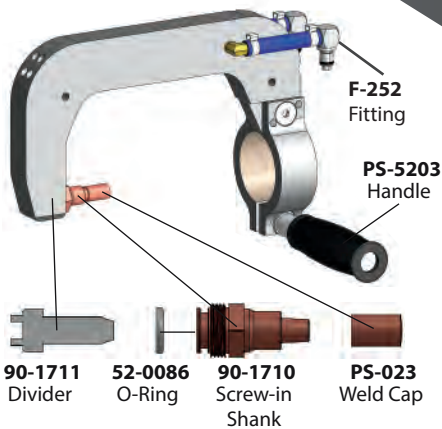

PSW-WH-090

Wheelhouse Arm, 90mm Depth

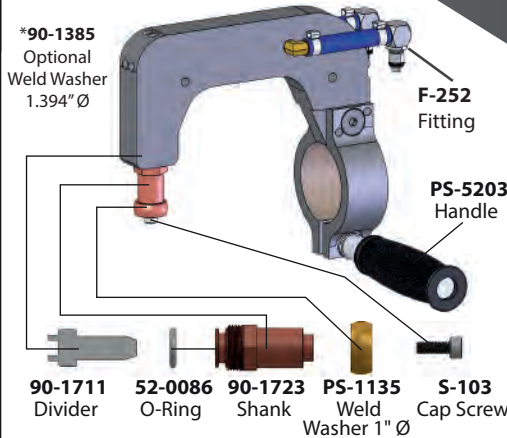

PSW-520

Extension Arm, 520mm Depth

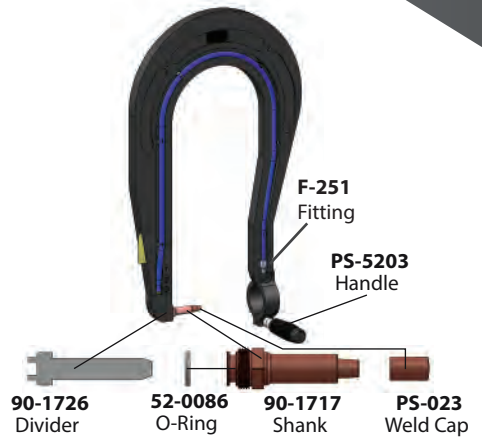









Component List

CL-i4s Rev C.

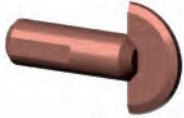
PRO SPOT

ORDER ONLINE @ store.prospot.com

Inside the Tool Tray

CLT-33 Stitch Electrode  1 pc.	<input type="checkbox"/>	PS-820 Nail & 4mm Stud  1 pc.	<input type="checkbox"/>	PS-830 5mm & 6mm Stud  1 pc.	<input type="checkbox"/>	PS-840 Washer Adapter  1 pc.	<input type="checkbox"/>	PS-870 Moulding Clip & Contact Shrinking  1 pc.	<input type="checkbox"/>	50-2010 Weld Coupon, 2"x10"  2 pc.
--	--------------------------	--	--------------------------	---	--------------------------	--	--------------------------	--	--------------------------	---

i4s ACCESSORY KIT

SA-0611 Rev.A

PS-1204 Moulding Clip Rivet  100 pc.	 CLT-54 Allen Wrench - 2mm 1 pc. CLT-57 Allen Wrench - 3mm 1 pc. CLT-58A Allen Wrench - 4mm 1 pc.	CLT-31-CM Electrode Shank - Single Sided 	CLT-53B 1 pc. Spot Hammer Contact Tip 	90-0451 Cooling Tube 1 pc. 	CLT-29 Carbon Electrode 1 pc. 
PS-1201 Weld-On Bolt M5x12 Coarse  50 pc.	CLT-44 Weld-On Nut, 6mm  20 pc.	PS-210 Nail 2.5 x 50mm  50 pc.	52-0086 O-Ring - Arm Side  5 pc.	PS-025 Weld Cap, A-Cap  7 pc.	
PS-1202 Weld-On Bolt M6x12  50 pc.	PS-230 Weld-On Bolt M5x18 Coarse  50 pc.	CLT-47 Weld-On Washer  50 pc.	52-0093 O-Ring - Gun Side  5 pc.	PS-023 Weld Cap, F-Cap  6 pc.	

OPTIONAL

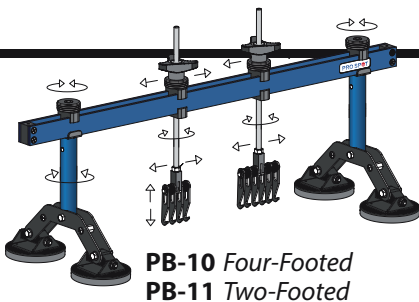

Pull Bar

Controlled pulls are made easy with the Pull Bar dent pulling system.



PSW-310

Extension Arm, 320mm Depth

Weld Tab Dent Pulling

Expand your Single-Sided welding capabilities.



PS-880 Tab Adapter



50-0016 Steel Pull Key



50-0017 Twisted Steel Pull Key



Electrode Tip Dresser
Extend the life of weld caps with Pro Spot's pneumatic tip dresser.

PLT-49/A F-Cap Dresser

PLT-50/A A-Cap Dresser

Pro Pull

Pro Spot's patented tool for fast and accurate dent pulling.

PRO-66



CXL-i4s

The X-type is designed to reach the few areas a C-type arm cannot.



CX-i4s

Copyright 2026 Pro Spot International, Inc.